

MO5357

60-220 MHz, ± 0.1 to ± 0.25 ppm, Stratum 3, Elite Platform™ Precision Super TC-MO



Description

The MO5357 is a ± 100 ppb precision MEMS Super-TC-MO that is fully compliant to Telcordia GR-1244-CORE Stratum 3 oscillator specifications. Engineered for best dynamic performance, the MO5357 is ideal for high reliability telecom, wireless and networking, industrial, precision GNSS and audio/video applications.

Leveraging KDS's unique DualMEMS™ temperature sensing and TurboCompensation™ technologies, the MO5357 delivers the best dynamic performance for timing stability in the presence of environmental stressors due to air flow, temperature perturbation, vibration, shock and electromagnetic interference. This device also integrates multiple on-chip regulators, providing power supply noise, eliminating the need for a dedicated external LDO.

The MO5357 offers three device configurations that can be ordered with the associated ordering codes for:

- 1) TC-MO with non-pullable output frequency,
- 2) VCTC-MO allowing voltage control of output frequency,
- 3) DCTC-MO enabling digital control of the output frequency using an I²C interface, pullable to 5 ppt (parts per trillion) resolution.

The MO5357 can be factory programmed for any combination of frequency, stability, voltage, and pull range. Programmability enables designers to optimize the clock configuration while eliminating the long lead time and customization cost associated with quartz TCXOs where each frequency is custom built.

Refer to Manufacturing Guideline for proper reflow profile and PCB cleaning recommendations to ensure best performance.

Block Diagram

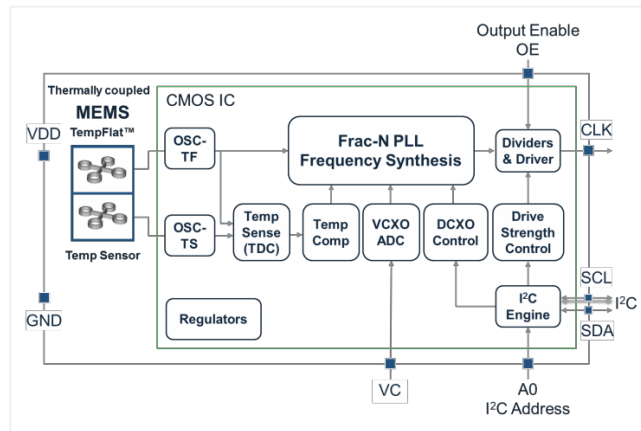

Figure 1. MO5357 Block Diagram

Features

- Output 60-189 MHz, and 200-220 MHz, in 1 Hz steps
- Factory programmable options for low lead time
- Best dynamic stability under airflow, thermal shock
 - ± 100 ppb over-temperature stability
 - ± 1 ppb/°C frequency slope ($\Delta F/\Delta T$)
 - $3e-11$ ADEV at 10 second averaging time
- -40°C to +105°C operating temperature
- No activity dips or micro jumps
- Resistant to shock, vibration and board bending
- On-chip regulators eliminate the need for external LDOs
- Digital frequency pulling (DCTC-MO) via I²C
 - Digital control of output frequency and pull range
 - Up to ± 3200 ppm pull range
 - Frequency pull resolution down to 5 ppt
- +2.5V, +2.8V, +3.0V and +3.3V supply voltage
- LVCMOS or clipped sinewave output
- RoHS and REACH compliant
- Pb-free, Halogen-free and Antimony-free

Applications

- 4G/5G radio, Small cell
- IEEE 1588 boundary and grandmaster clocks
- Carrier-grade routers and switches
- Synchronous Ethernet
- Optical transport – SONET/SDH, OTN, Stratum 3
- DOCSIS 3.x remote PHY
- Precision GNSS systems
- Test and measurement

5.0 x 3.2 mm² Package Pinout

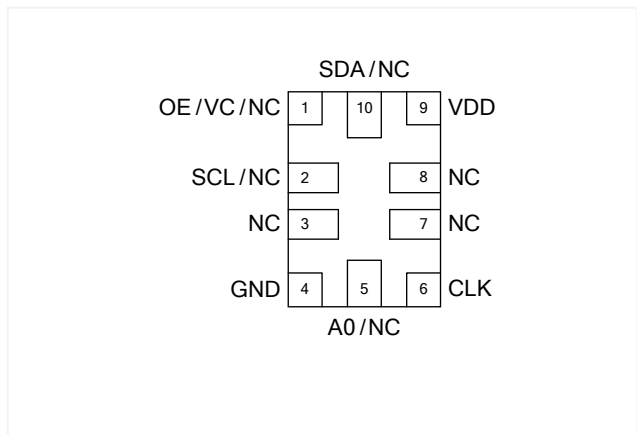
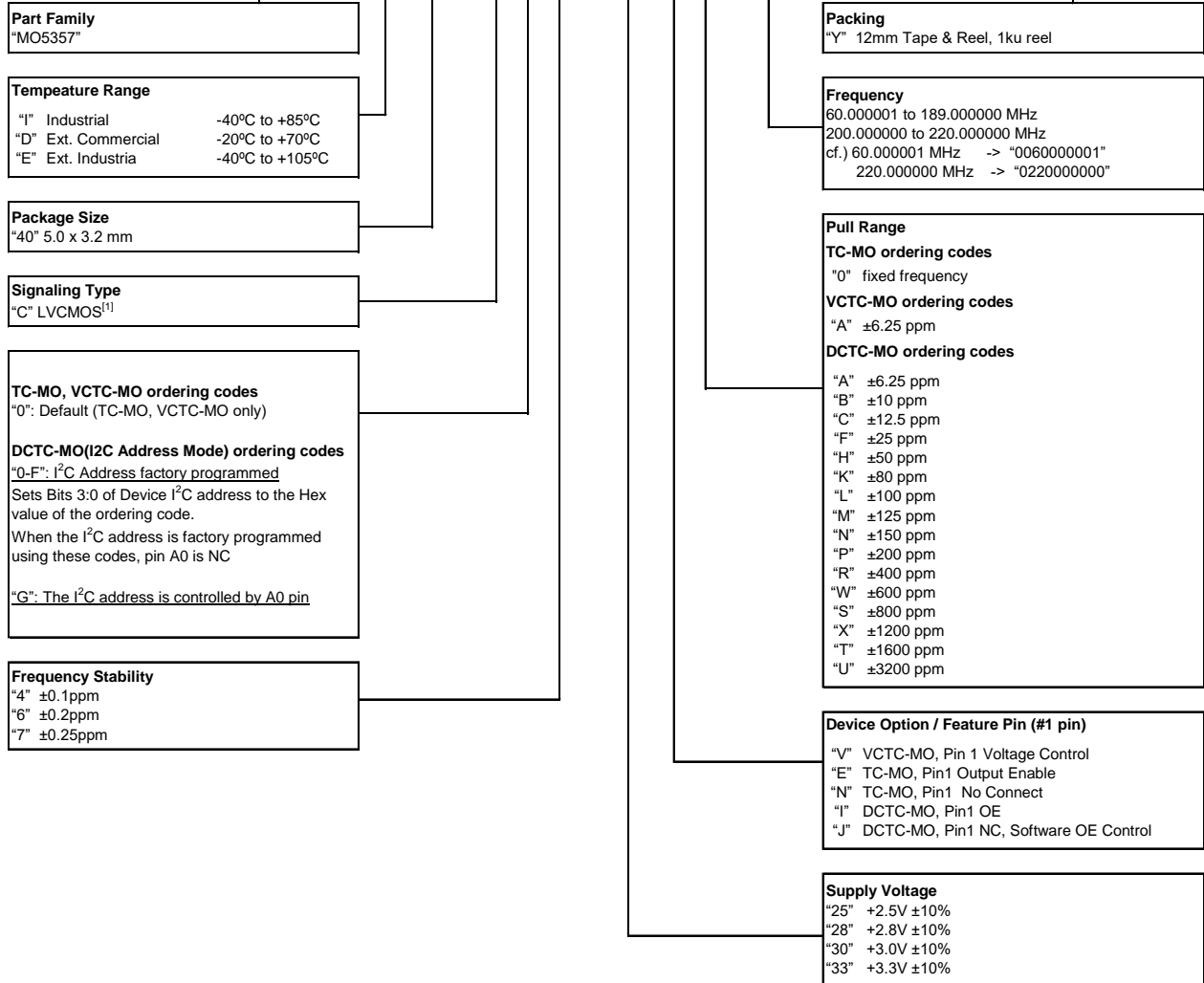

Figure 2. Pin Assignments (Top view)
(Refer to Table 13 for Pin Descriptions)

Ordering Information

TC-MO	M	O	5	3	5	7	D	4	0	-	C	0	4	-	3	3	E	0	-	0	0	1	9	1	2	3	4	5	6	Y
VCTC-MO	M	O	5	3	5	7	D	4	0	-	C	0	4	-	3	3	V	A	-	0	0	1	9	1	2	3	4	5	6	Y
DCTC-MO	M	O	5	3	5	7	D	4	0	-	C	G	4	-	3	3	J	B	-	0	0	1	9	1	2	3	4	5	6	Y



Notes:

- "C" corresponds to the default rise/fall time for LVCMOS output as specified in Table 1 (Electrical Characteristics). Contact KDS for other rise/fall time options for best EMI.

TABLE OF CONTENTS

Description 1

Features..... 1

Applications 1

Block Diagram 1

5.0 x 3.2 mm Package Pinout 1

Ordering Information 2

Electrical Characteristics..... 4

Device Configurations and Pin-outs..... 9

 Pin-out Top Views..... 9

Test Circuit Diagrams for LVCMOS and Clipped Sinewave Outputs 10

Waveforms..... 11

Timing Diagrams..... 11

Typical Performance Plots..... 12

Architecture Overview..... 15

 Frequency Stability 15

 Output frequency and format 15

 Output Frequency Tuning 15

 Pin 1 Configuration (OE, VC, or NC) 16

Device Cofigurations..... 16

 TC-MO Cofiguration..... 16

 VCTC-MO Cofiguration..... 17

 DCTC-MO Cofiguration 18

VCTC-MO-Specific Design Considerations 19

 Linearity 19

 Control Volgate Bandwidth 19

 FV Characteristic Slope Kv 19

 Pull Range, Absolute Pull Range..... 20

DCTC-MO-Specific Design Considerations 21

 Pull Range and Absolute Pull Range..... 21

 Output Frequency 22

 I²C Control Registers 24

 Register Discriptions..... 24

 Register Address: 0x00. Digital Frequency Control Least Significant Word (LSW) 24

 Register Address: 0x01. OE Control, Digital Frequency Control Most Significant Word (MSW)..... 25

 Register Address: 0x02. DIGITAL PULL RANGE CONTROL^[13]..... 26

 Serial Interface Configuration Discription..... 27

 Serial Signal Format 27

 Parallel Signal Format 28

 Parallel Data Format..... 28

 I²C Timing Specification..... 30

 I²C Device Address Modes 31

 Schematic Example 32

Dimensions and Patterns..... 33

Layout Guidelines 34

Manufacturing Guideline 34

Electrical Characteristics

All Min and Max limits are specified over temperature and rated operating voltage with 15 pF output load unless otherwise stated. Typical values are at +25°C and +3.3V Vdd

Table 1. Output Characteristics

Parameters	Symbol	Min.	Typ.	Max.	Unit	Condition
Frequency Coverage						
Output Frequency Range	F _{nom}	60.000001	–	189	MHz	
		200	–	220	MHz	
Temperature Range						
Operating Temperature Range	T _{use}	-20	–	+70	°C	Extended Commercial, ambient temperature
		-40	–	+85	°C	Industrial, ambient temperature
		-40	–	+105	°C	Extended Industrial, ambient temperature
Frequency Stability - Stratum 3+ Grade						
Initial Tolerance	F _{init}	-0.5	–	+0.5	ppm	Initial frequency at +25°C inclusive of solder-down shift at 48 hours after 2 reflows
Supply Voltage Sensitivity	F _{Vdd}	-2.5	±0.5	+2.5	ppb	Vdd ±5%
Output Load Sensitivity	F _{load}	-0.4	±0.05	+0.4	ppb	15 pF ±10%
Frequency Stability over Temperature	F _{stab}	-0.1	–	+0.1	ppm	Referenced to (max frequency + minimum frequency)/2 over the specified temperature range, in TC-MO, DCTC-MO, or VCTC-MO(VCTC-MO with ±6.25 ppm pull range)
Frequency vs. Temperature Slope	ΔF/ΔT	-2	±0.9	+2	ppb/°C	-20 to +85°C
		-3.5	±1	+3.5	ppb/°C	-40 to -20°C
		–	±0.9	–	ppb/°C	+85 to +105°C
Dynamic Frequency Change during Temperature Ramp	F _{dynamic}	-0.02	±0.008	+0.02	ppb/s	0.5°C/min temperature ramp rate, -20 to +85°C
		-0.035	±0.01	+0.035	ppb/s	0.5°C/min temperature ramp rate, -40 to -20°C
		–	±0.008	–	ppb/s	0.5°C/min temperature ramp rate, +85 to +105°C
24-hour holdover stability	F _{24_Hold}	-0.15	–	+0.15	ppm	Inclusive of over-temp frequency variation
Hysteresis Over Temperature	F _{hys}	–	±25	–	ppb	-40 to +105°C , 0.5°C/min ramp rate,
		–	±15	–	ppb	-40 to +85°C , 0.5°C/min ramp rate,
		–	±10	–	ppb	-20 to +70°C , 0.5°C/min ramp rate,
One-Day Aging	F _{1d}	–	±1	–	ppb	At +25°C, after 30-days of continued operation. Aging is measured with respect to day 31
One-Year Aging	F _{1y}	–	±0.3	–	ppm	At +25°C, after 2-days of continued operation. Aging is measured with respect to day 3
20-Year Aging	F _{20y}	–	±0.5	–	ppm	
Frequency Stability - Stratum 3 Grade						
Initial Tolerance	F _{init}	-1	–	+1	ppm	Initial frequency at +25°C inclusive of solder-down shift at 48 hours after 2 reflows
Supply Voltage Sensitivity	F _{Vdd}	-6.5	±4.2	+6.5	ppb	Vdd ±5%
Output Load Sensitivity	F _{load}	-1.1	±0.3	+1.1	ppb	15 pF ±10%.
Frequency Stability over Temperature	F _{stab}	-0.2	–	+0.2	ppm	Referenced to (max frequency + min frequency)/2 over the rated temperature range. Vc=Vdd/2 for VCTC-MO
		-0.25	–	+0.25	ppm	
Frequency vs. Temperature Slope	ΔF/ΔT	-10	±6.4	+10	ppb/°C	-40 to +105°C
Dynamic Frequency Change during Temperature Ramp	F _{dynamic}	-0.8	±0.05	+0.08	ppb/s	0.5°C/min temperature ramp rate
24-hour holdover	F _{24_Hold}	-0.32	–	+0.32	ppm	Inclusive of over-temperature frequency variation
One-Day Aging	F _{1d}	-5	±3	+5	ppb	At +25°C, after 30-days of continued operation. Aging is measured with respect to day 31.
One-Year Aging	F _{1y}	–	±1	–	ppm	At +25°C, after 2-days of continued operation.
20-Year Aging	F _{20y}	–	±2	–	ppm	Aging is measured with respect to day 3.
20-Year Total Stability	F _{20yT}	-4.6	–	+4.6	ppm	Complies with Stratum 3 per GR-1244-CORE. Actual performance is better.

Table 1. Output Characteristics (continued)

Parameters	Symbol	Min.	Typ.	Max.	Unit	Condition
LVC MOS Output Characteristics						
Duty Cycle	DC	45	–	55	%	60 to 150 MHz
		42	–	55	%	150 to 189 MHz, 200 to 220 MHz
Rise/Fall Time	Tr, Tf	0.8	1.2	1.9	ns	10% - 90% Vdd
Output Voltage High	VOH	90%	–	–	Vdd	IOH = +3 mA
Output Voltage Low	VOL	–	–	10%	Vdd	IOL = -3 mA
Start-up Characteristics						
Start-up Time	T_start	–	2.5	3.5	ms	Time to first pulse, measured from the time Vdd reaches 90% of its final value. Vdd ramp time = 100 µs from 0V to Vdd.
Output Enable Time	T_oe	–	–	285	ns	See Timing Diagrams section below.
First Pulse Accuracy	T_stability	–	5	45	ms	Time to first accurate pulse within rated stability, measured from the time Vdd reaches 90% of its final value. Vdd ramp time = 100 µs

Table 2. DC Characteristics

Parameters	Symbol	Min.	Typ.	Max.	Unit	Condition
Supply Voltage						
Supply Voltage	Vdd	+2.25	+2.5	+2.75	V	Contact KDS for +2.25V to +3.63V continuous supply voltage support
		+2.52	+2.8	+3.08	V	
		+2.7	+3.0	+3.3	V	
		+2.97	+3.3	+3.63	V	
Current Consumption						
Current Consumption	Idd	–	+48	+62	mA	F = 100 MHz, No Load, TC-MO ,DCTC-MO
		–	+52	+66	mA	F = 100 MHz, No Load, VCTC-MO
OE Disable Current	I_od	–	+45	+52	mA	OE = GND, output weakly pulled down , TC-MO, DCTC-MO
		–	+49	+56	mA	OE = GND, output weakly pulled down , VCTC-MO

Table 3. Input Characteristics

Parameters	Symbol	Min.	Typ.	Max.	Unit	Condition
Input Characteristics – OE Pin						
Input Impedance	Z _{in}	75	–	–	kΩ	Internal pull up to Vdd
Input High Voltage	V _{IH}	70%	–	–	Vdd	
Input Low Voltage	V _{IL}	–	–	30%	Vdd	
Frequency Tuning Range – Voltage Control or I²C mode						
Pull Range	PR	±6.25	–	–	ppm	VCTC-MO mode. Contact KDS for ±12.5 and ±25 ppm.
		±6.25	–	–	ppm	DCTC-MO mode
		±10				
		±12.5				
		±25				
		±50				
		±80				
		±100				
		±125				
		±150				
		±200				
		±400				
±600						
±800						
±1200						
±1600						
±3200						
Absolute Pull Range ^[2]	APR	±5.15	–	–	ppm	±0.1 ppm F _{stab} , DCTC-MO, VCTC-MO for PR = ±6.25 ppm
		±3.05	–	–	ppm	±0.2 ppm F _{stab} , DCTC-MO, VCTC-MO for PR = ±6.25 ppm
		±3.00	–	–	ppm	±0.25 ppm F _{stab} , DCTC-MO, VCTC-MO for PR = ±6.25 ppm
Upper Control Voltage	VC _U	90%	–	–	Vdd	VCTC-MO mode
Lower Control Voltage	VC _L	–	–	10%	Vdd	VCTC-MO mode
Control Voltage Input Impedance	VC _z	8	–	–	MΩ	VCTC-MO mode
Control Voltage Input Bandwidth	VC _{bw}	–	10	–	kHz	VCTC-MO mode
Frequency Control Polarity	F _{pol}	Positive				VCTC-MO mode
Pull Range Linearity	PR _{lin}	–	0.5	1.0	%	VCTC-MO mode
I²C Interface Characteristics, 200 Ohm, 550 pF (Max I²C Bus Load)						
Bus Frequency	F _{I2C}	–	100	–	kHz	-40 to +105°C
		–	400	–	kHz	-40 to +105°C
		–	1000	–	kHz	-40 to +85°C
Input Voltage Low	V _{IL_I2C}	–	–	30%	Vdd	DCTC-MO mode
Input Voltage High	V _{IH_I2C}	70%	–	–	Vdd	DCTC-MO mode
Output Voltage Low	V _{OL_I2C}	–	–	+0.4	V	DCTC-MO mode
Input Leakage current	I _L	+0.5	–	+24	μA	0.1 Vdd < V _{OUT} < 0.9Vdd. Includes typical Leakage current from 200 kΩ pull resistor to Vdd. DCTC-MO mode
Input Capacitance	C _{IN}	–	–	5	pF	DCTC-MO mode

Notes:

2. APR = PR – initial tolerance – 20-year aging – frequency stability over temperature. Refer to Table 14 for APR with respect to other pull range options.

Table 2. Jitter & Phase Noise, -40 to +85°C

Parameters	Symbol	Min.	Typ.	Max.	Unit	Condition
Jitter						
RMS Phase Jitter (random)	T_phj	–	0.31	0.48	ps	F_nom = 100 MHz Integration bandwidth = 12 kHz to 20 MHz
RMS Period Jitter	T_jitt	–	1.0	1.8	ps	F_nom = 100 MHz, population 10k
Peak Cycle-to-Cycle Jitter	T_jitt_cc	–	6.6	13.4	ps	F_nom = 100 MHz, population 1k measured as absolute value
Phase Noise						
1 Hz offset		–	-61	-54	dBc/Hz	F_nom = 100 MHz TC-MO and DCTC-MO modes, and VCTC-MO mode with ±6.25 ppm pull range
10 Hz offset		–	-89	-83	dBc/Hz	
100 Hz offset		–	-107	-103	dBc/Hz	
1 kHz offset		–	-128	-124	dBc/Hz	
10 kHz offset		–	-133	-131	dBc/Hz	
100 kHz offset		–	-133	-130	dBc/Hz	
1 MHz offset		–	-150	-146	dBc/Hz	
5 MHz offset		–	-157	-151	dBc/Hz	
10 MHz offset		–	-157	-152	dBc/Hz	
20 MHz offset		–	-159	-152	dBc/Hz	
Spurious	T_spur	–	-91	-86	dBc	F_nom = 100 MHz, 1 kHz to 40 MHz offsets

Table 5. Jitter & Phase Noise, -40 to +105°C

Parameters	Symbol	Min.	Typ.	Max.	Unit	Condition
Jitter						
RMS Phase Jitter (random)	T_phj	–	0.31	0.50	ps	F_nom = 100 MHz Integration bandwidth = 12 kHz to 20 MHz
RMS Period Jitter	T_jitt	–	1.0	1.8	ps	F_nom = 100 MHz, population 10k
Peak Cycle-to-Cycle Jitter	T_jitt_cc	–	6.6	13.4	ps	F_nom = 100 MHz, population 1k measured as absolute value
Phase Noise						
1 Hz offset		–	-61	-54	dBc/Hz	F_nom = 100 MHz TC-MO and DCTC-MO modes, and VCTC-MO mode with ±6.25 ppm pull range
10 Hz offset		–	-89	-83	dBc/Hz	
100 Hz offset		–	-107	-103	dBc/Hz	
1 kHz offset		–	-128	-124	dBc/Hz	
10 kHz offset		–	-133	-131	dBc/Hz	
100 kHz offset		–	-133	-130	dBc/Hz	
1 MHz offset		–	-150	-144	dBc/Hz	
5 MHz offset		–	-157	-150	dBc/Hz	
10 MHz offset		–	-157	-150	dBc/Hz	
20 MHz offset		–	-159	-150	dBc/Hz	
Spurious	T_spur	–	-91	-85	dBc	F_nom = 100 MHz, 1 kHz to 40 MHz offsets

Table 6. Absolute Maximum Limits

Attempted operation outside the absolute maximum ratings may cause permanent damage to the part. Actual performance of the IC is only guaranteed within the operational specifications, not at absolute maximum ratings.

Parameter	Test Conditions	Value	Unit
Storage Temperature		-65 to +125	°C
Continuous Power Supply Voltage Range (Vdd)		-0.5 to +4	V
Human Body Model (HBM) ESD Protection	JESD22-A114	2000	V
Soldering Temperature (follow standard Pb-free soldering guidelines)		+260	°C
Junction Temperature ^[3]		+130	°C

Note:

3. Exceeding this temperature for an extended period of time may damage the device.

Table 7. Thermal Considerations^[4]

Package	θ_{JA} (°C/W)	$\theta_{JC, Bottom}$ (°C/W)
Ceramic 5.0 x 3.2 mm ²	54	15

Note:

4. Measured in still air.

Table 8. Maximum Operation Junction Temperature^[5]

Max Operating Temperature (ambient)	Maximum Operating Junction Temperature
+70 °C	+80 °C
+85 °C	+95 °C
+105 °C	+115 °C

Note:

5. Datasheet specifications are not guaranteed if junction temperature exceeds the maximum operating junction temperature.

Table 9. Environmental Compliance

Parameter	Test Conditions	Value	Unit
Mechanical Shock Resistance	MIL-STD-883F, Method 2002	10000	<i>g</i>
Mechanical Vibration Resistance	MIL-STD-883F, Method 2007	70	<i>g</i>
Temperature Cycle	JESD22, Method A104	–	–
Solderability	MIL-STD-883F, Method 2003	–	–
Moisture Sensitivity Level	MSL1 @260°C	–	–

Device Configurations and Pin-outs

Table 10. Device Configurations

Configuration	Pin 1	Pin 5	I ² C Programmable Parameters
TC-MO	OE/NC	NC	–
VCTC-MO	VC	NC	–
DCTC-MO	OE/NC	A0/NC	Frequency Pull Range, Frequency Pull Value, Output Enable control

Pin-out Top Views

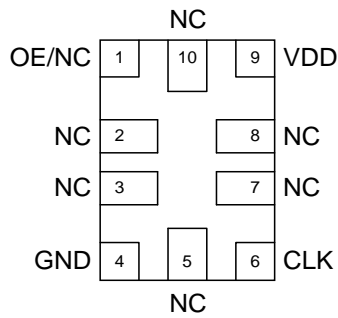

Figure 3. TC-MO

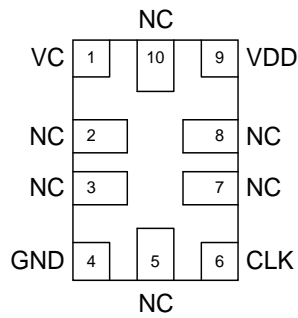

Figure 4. VCTC-MO

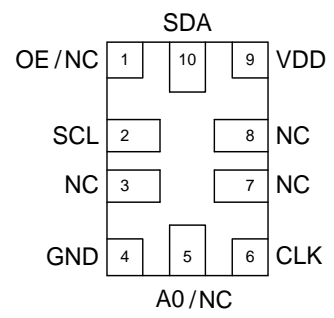

Figure 5. DCTC-MO

Table 11. Pin Description

Pin	Symbol	I/O	Internal Pull-up/Pull Down Resistor	Function
1	OE/NC/VC	OE – Input	100 kΩ Pull-Up	H ^[6] : specified frequency output L: output is high impedance. Only output driver is disabled
		NC ^[8] – No Connect	-	H or L or Open: No effect on output frequency or other device functions
		VC – Input	-	Control Voltage in VCTC-MO Mode
2	SCL/NC ^[8]	SCL - Input	200 kΩ Pull-Up	I ² C Serial Clock Input
		NC – No Connect	-	H or L or Open: No effect on output frequency or other device functions
3	NC ^[8]	No Connect	-	H or L or Open: No effect on output frequency or other device functions
4	GND	Power	-	Connect to ground
5	A0/NC ^[8]	A0 – Input	100 kΩ Pull-Up	Device I ² C address when the address selection mode is via the A0 pin. This pin is NC when the I ² C device address is specified in the ordering code. <u>A0 Logic Level</u> <u>I²C Address</u> 0 1100010 1 1101010
		NC – No Connect	-	H or L or Open: No effect on output frequency or other device functions
6	CLK	Output	-	LVCMOS
7	NC ^[8]	No Connect	-	H or L or Open: No effect on output frequency or other device functions
8	NC ^[8]	No Connect	-	H or L or Open: No effect on output frequency or other device functions
9	VDD	Power	-	Connect to VDD ^[7]
10	SDA/NC ^[7]	SDA – Input/Output	200 kΩ Pull-Up	I ² C Serial Data.
		NC - No Connect	-	H or L or Open: No effect on output frequency or other device functions

Notes:

- In OE mode for noisy environments, a pull-up resistor of 10 kΩ or less is recommended if pin 1 is not externally driven. If pin 1 needs to be left floating, use the NC option.
- 0.1 μF capacitor in parallel with a 10 μF capacitor are required between Vdd and GND. The 0.1 μF capacitor is recommended to place close to the device, and place the 10 μF capacitor less than 2 inches away.
- All NC pins can be left floating and do not be soldered down.

Test Circuit Diagrams for LVCMOS Outputs

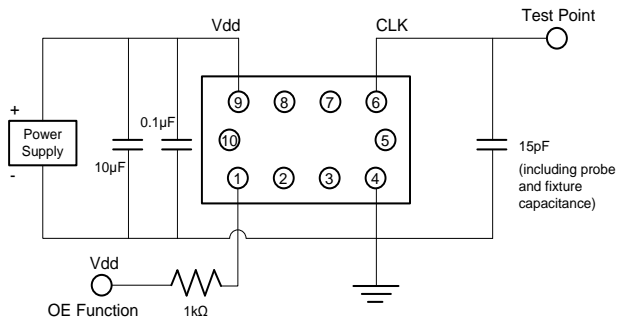

Figure 6. LVCMOS Test Circuit (OE Function)

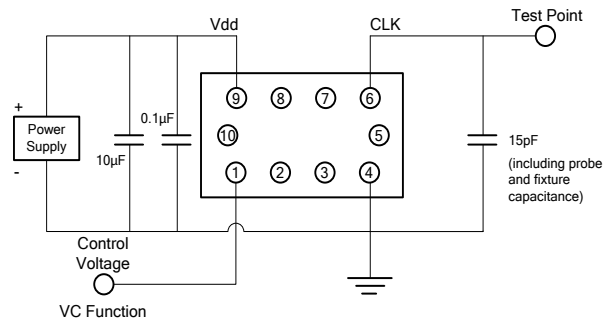

Figure 7. LVCMOS Test Circuit (VC Function)

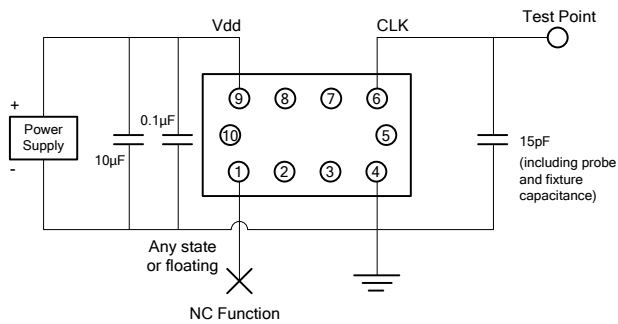

Figure 8. LVCMOS Test Circuit (NC Function)

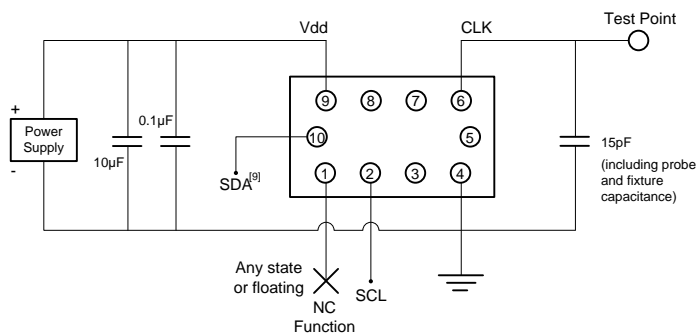

Figure 9. LVCMOS Test Circuit (I²C Control), DCTC-MO mode

Notes:

9. SDA is open-drain and may require pull-up resistor if not present in I²C test setup.

Waveforms

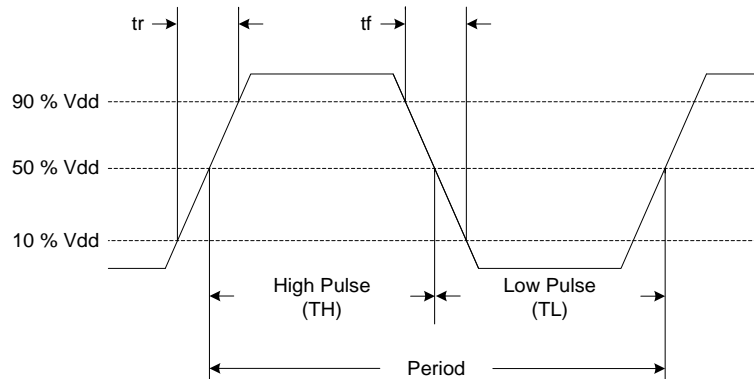
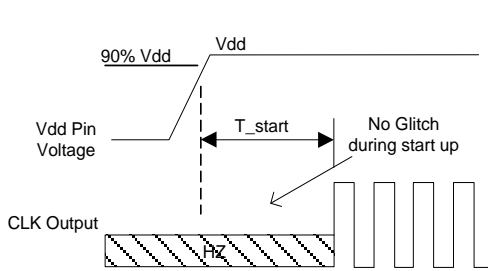

Figure 10. LVCMOS Waveform Diagram^[10]

Notes

10. Duty Cycle is computed as $Duty\ Cycle = TH/Period$.

Timing Diagrams



T_{start} : Time to start from power-off

Figure 11. Startup Timing

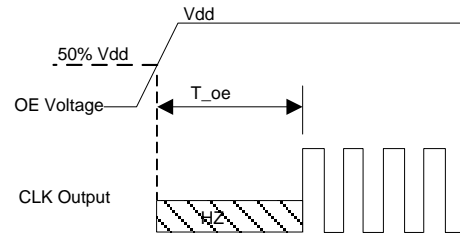

T_{oe} : Time to re-enable the clock output

Figure 12. OE Enable Timing (OE Mode Only)

Typical Performance Plots

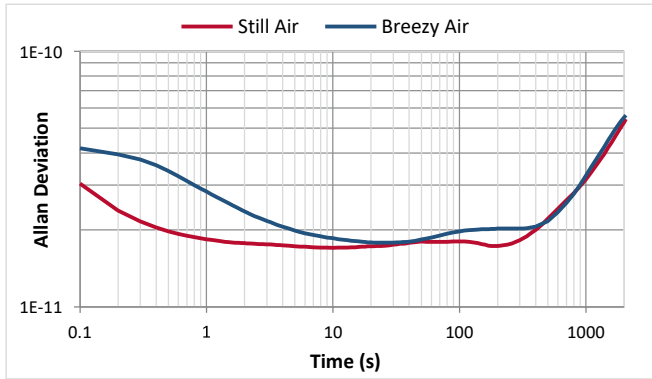

Figure 13. ADEV(± 0.1 ppm)

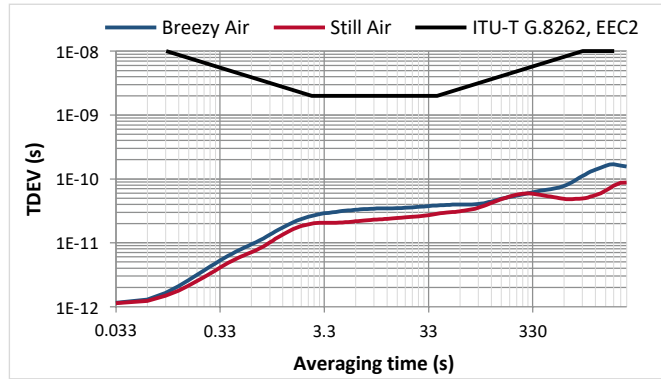

Figure 14. TDEV (0.1 Hz loop bandwidth, ± 0.1 ppm)

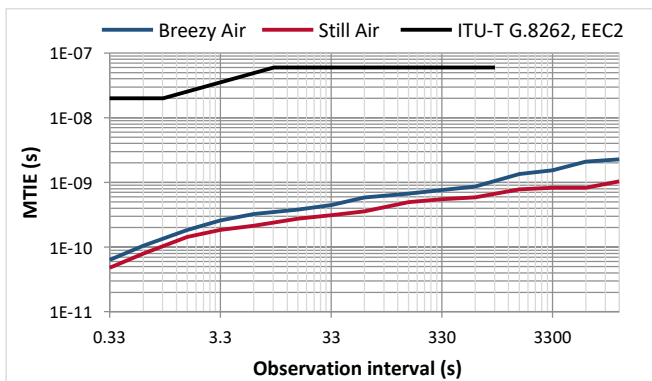

Figure 15. MTIE (0.1 Hz loop bandwidth, ± 0.1 ppm)

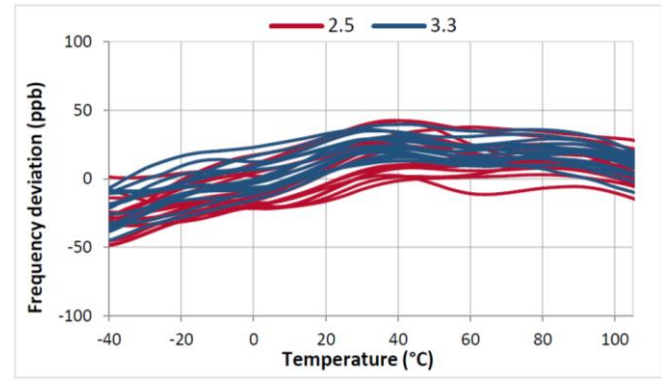

Figure 16. Frequency vs Temperature (± 0.1 ppm), +105°C

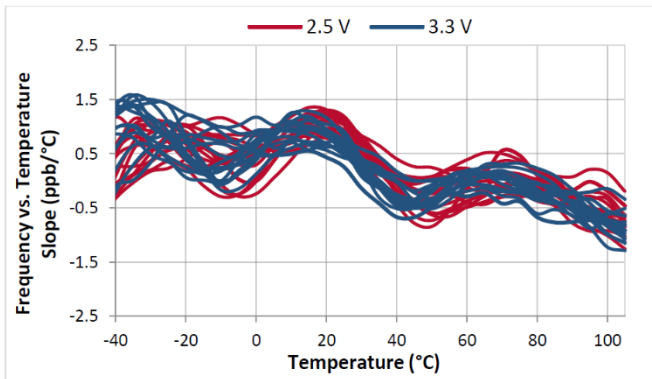

Figure 17. Freq. vs. Temp. Slope ($\Delta F/\Delta T$), ± 0.1 ppm device

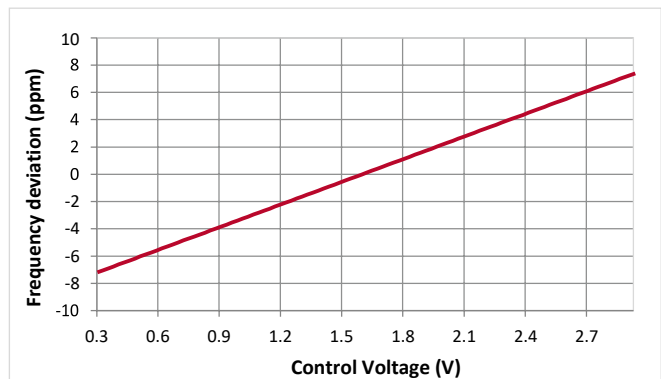

Figure 18. VCTC-MO frequency pull characteristic

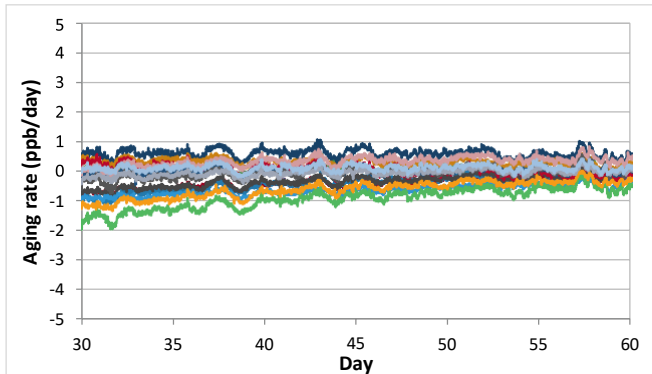

Figure 19. 1-day aging rate (to 62 days), ± 0.1 ppm device

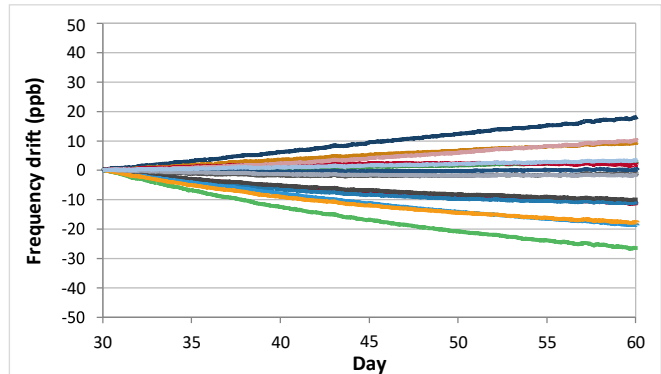

Figure 20. Drift over 30 days relative to the first reading

Typical Performance Plots (continued)

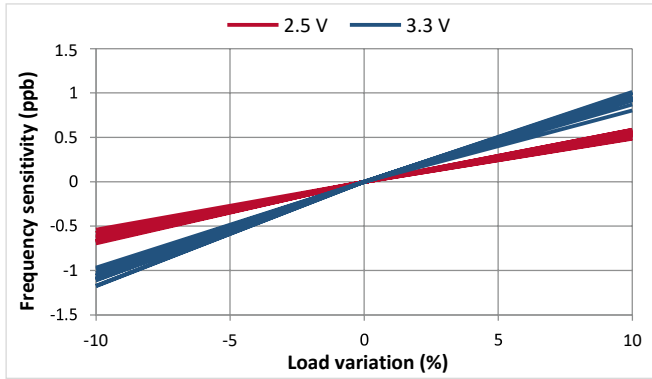

Figure 21. Load sensitivity (± 0.1 ppm)

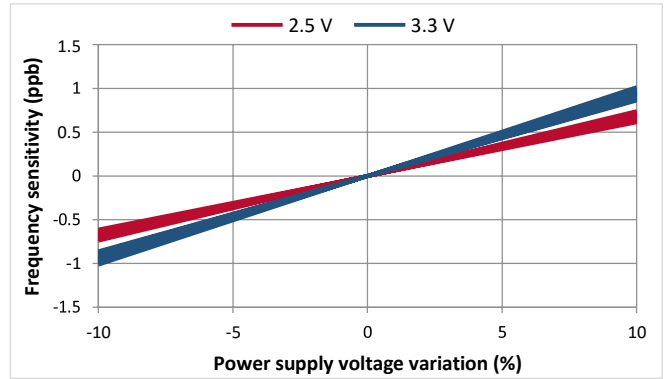

Figure 22. VDD sensitivity (± 0.1 ppm)

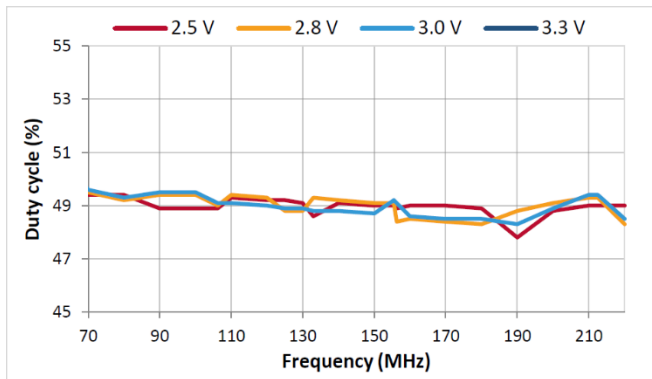

Figure 23. Duty Cycle (LVCMOS)

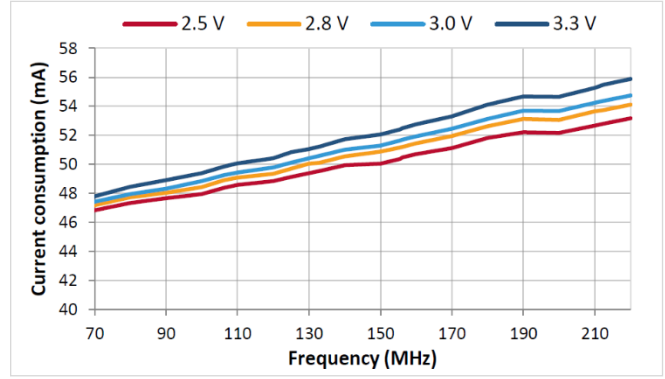

Figure 24. IDD DCTC-MO (LVCMOS)

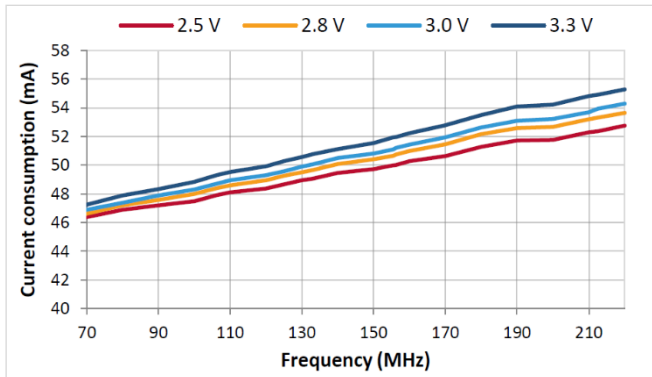

Figure 25. IDD TC-MO (LVCMOS)

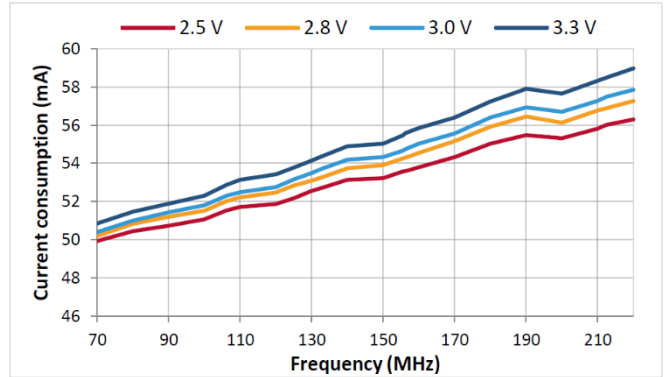

Figure 26. IDD VCTC-MO (LVCMOS)

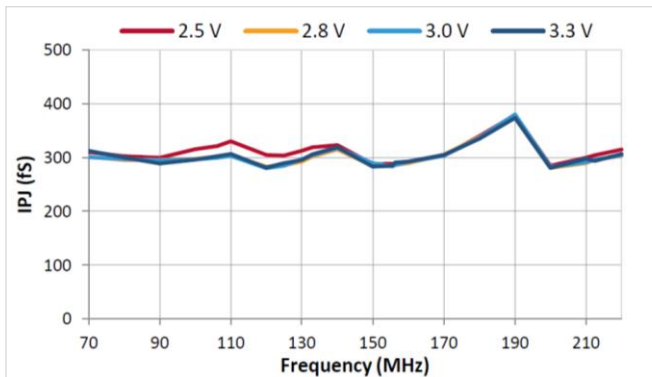

Figure 27. T_{phj}, RMS Random, (DC)TC-MO (LVCMOS)

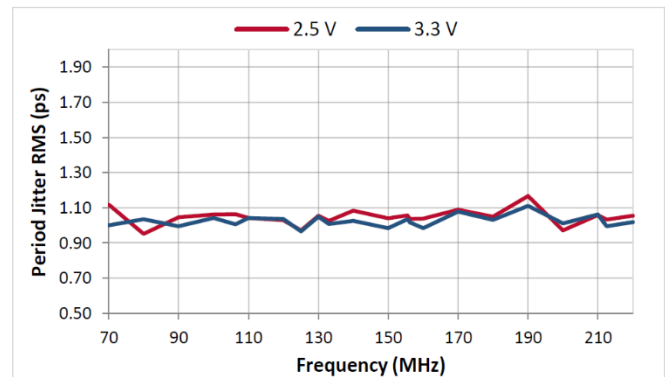

Figure 28. Period Jitter, RMS (LVCMOS)

Typical Performance Plots (continued)

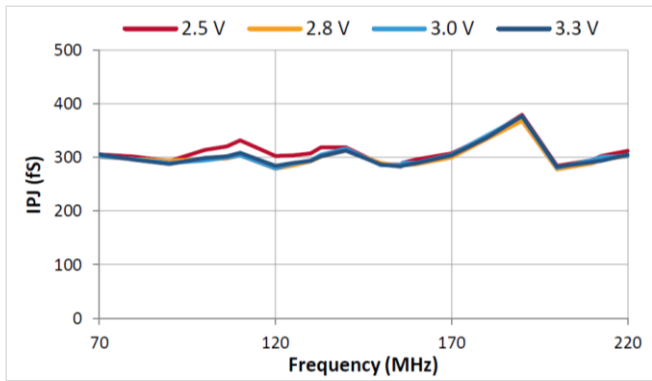

Figure 29. T_phj, RMS Random, VCTC-MO (LVCMOS)

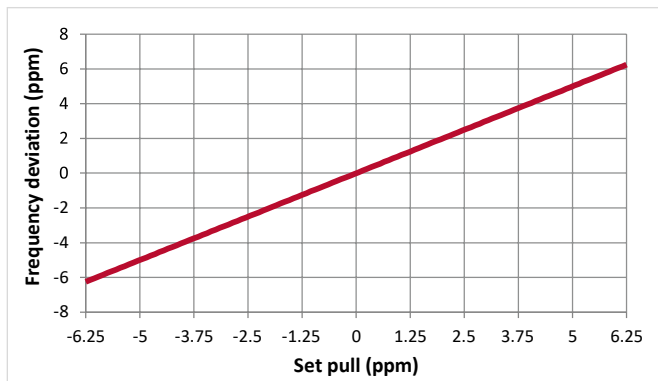

Figure 30. DCTC-MO frequency pull characteristic

Architecture Overview

Based on KDS's innovative Elite Platform, the MO5357 delivers exceptional dynamic performance, i.e. resilience to environmental stressors such as shock, vibration and fast temperature transients. Underpinning the Elite platform are KDS's unique DualMEMS temperature sensing architecture and TurboCompensation technologies.

DualMEMS is a noiseless temperature sensing scheme. It consists of two MEMS resonators fabricated on the same die substrate. The TempFlat resonator is designed with a flat frequency characteristic over temperature whereas the temperature sensing resonator is by design sensitive to temperature changes. The ratio of frequencies between these two resonators provides an accurate reading of the resonator temperature with 20 µK resolution.

By placing the two MEMS resonators on the same die, this temperature sensing scheme eliminates the thermal lag and gradients between the resonator and the temperature sensor, thereby overcoming an inherent weakness of the legacy quartz TCXOs.

The DualMEMS temperature sensor drives a state-of-the-art CMOS temperature compensation circuit. The TurboCompensation design, with >100 Hz compensation bandwidth, achieves dynamic frequency stability that is far superior to any quartz TCXO. The digital temperature compensation enables additional optimization of frequency stability and frequency slope over temperature within any chosen temperature range for a given system design.

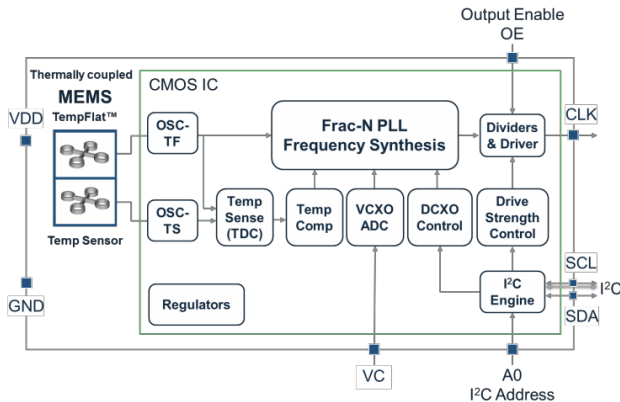

Figure 318. Elite Architecture

The Elite platform also incorporates a high resolution, low noise frequency synthesizer along with the industry standard I²C bus. This unique combination enables system designers to digitally control the output frequency in steps as low as 5 ppt and over a wide range up to ±3200 ppm.

For more information regarding the Elite platform and its benefits please contact KDS.

Functional Overview

The MO5357 is designed for maximum flexibility with an array of factory programmable options, enabling system designers to configure this precision device for optimal performance in a given application.

Frequency Stability

The MO5357 comes in two factory-trimmed stability grades that are optimized for different applications. Both Stratum 3+ and Stratum 3 devices are compliant with Stratum 3 stability of ±4.6 ppm over 20 years.

Table 12. Stability Grades vs. Ordering Codes

Grade	Frequency Slope (ΔF/ΔT)	Frequency Stability Over Temperature	Ordering Code
Stratum 3+	±3.5 ppb/°C	±0.1 ppm	Q
Stratum 3	±10 ppb/°C	±0.2 ppm	P
		±0.25 ppm	N

- Stratum 3+ grade with ΔF/ΔT of ±3.5 ppb/°C is engineered to provide significantly better performance than legacy quartz TCXOs in time and phase synchronization applications such as IEEE1588, small cells, and 5G C-RAN (cloud RAN).
- Stratum 3 grade is designed to replace classic Stratum 3 TCXOs in applications such as SyncE with better dynamic performance and shorter lead time.

Output frequency and format

The MO5357 can be factory programmed for an output frequency without sacrificing lead time or incurring an upfront customization cost typically associated with custom-frequency quartz TCXOs.

Output Frequency Tuning

In addition to the non-pullable TCXO, the MO5357 can also support output frequency tuning through either an analog control voltage (VCTC-MO), or I²C interface (DCTC-MO). The I²C interface enables 16 factory programmed pull-range options from ±6.25 ppm to ±3200 ppm. The pull range can also be reprogrammed via I²C to any supported pull-range value.

Refer to Device Configuration section for details.

Pin 1 Configuration (OE, VC, or NC)

Pin 1 of the MO5357 can be factory-programmed to support three modes: Output Enable (OE), Voltage Control (VC) or No Connect (NC).

Table 3. Pin Configuration Options

Pin 1 Configuration	Operating Mode	Output
OE	TC-MO/DCTC-MO	Active or High-Z
NC	TC-MO/DCTC-MO	Active
VC	VCTC-MO	Active

When pin 1 configured as OE pin, the device output is guaranteed to operate in one of the following two states:

- Clock output with the frequency specified in the part number when Pin 1 is pulled to logic high
- Hi-Z mode with weak pull down when pin 1 is pulled to logic low.

When pin 1 is configured as NC, the device is guaranteed to output the frequency specified in the part number at all times, regardless of the logic level on pin 1.

In the VCTC-MO configuration, the user can fine-tune the output frequency from the nominal frequency specified in the part number by varying the pin 1 voltage. The guaranteed allowable variation of the output frequency is specified as pull range. A VCTC-MO part number must contain a valid pull-range ordering code.

Device Configurations

The MO5357 supports 3 device configurations – TC-MO, VCTC-MO and DCTC-MO. The TC-MO and VCTC-MO options are directly compatible with the quartz TCXO and VTCXO. The DCTC-MO configuration provides performance enhancement by eliminating VCTC-MO’s sensitivity to control voltage noise with an I²C digital interface for frequency tuning.

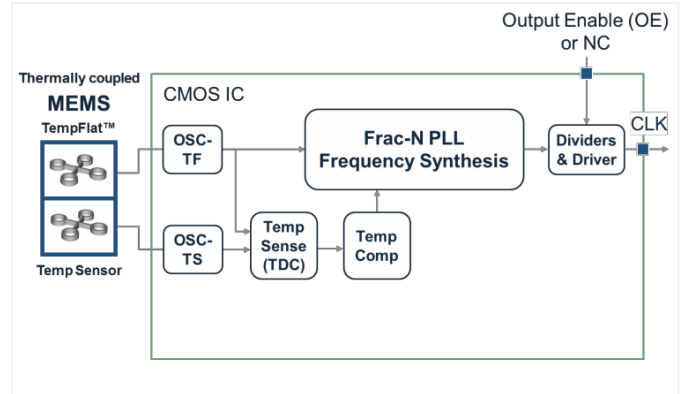

Figure 32. Block Diagram – TC-MO

TC-MO Configuration

The TC-MO configuration generates a fixed frequency output, as shown in Figure 32. The frequency is specified by the user in the frequency field of the device ordering code and then factory programmed. Other factory programmable options include supply voltage, output types (LVCMOS or clipped sinewave), and pin 1 functionality (OE or NC).

Refer to the ordering information section at the end of the datasheet for a list of all ordering options.

VCTC-MO Configuration

A VCTC-MO, shown in Figure 33, is a frequency control device whose output frequency is an approximately linear function of control voltage applied to the voltage control pin. VCTC-MOs have a number of use cases including the VCO portion of a jitter attenuation/jitter cleaner PLL Loop.

The MO5357 achieves a 10x better pull range linearity of $<0.5\%$ via a high-resolution fractional PLL compared with 5% to 10% typical of quartz VCTCXOs that rely on pulling a resonator. By contrast, quartz-based VCTCXOs change output frequency by varying the capacitive load of a crystal resonator using varactor diodes, which results in poor linearity.

Note that the output frequency of the VCTC-MO is proportional to the analog control voltage applied to pin 1. Because this control signal is analog and directly controls the output frequency, care must be taken to minimize noise on this pin.

The nominal output frequency is factory programmed per the customer's request to 6 digits of precision and is defined as the output frequency when the control voltage equals $V_{dd}/2$. The maximum output frequency variation from this nominal value is set by the pull range, which is also factory programmed to the customer's desired value and specified by the ordering code. The Ordering Information section shows all ordering options and associated ordering codes.

Refer to Appendix 1 Design Considerations with VCTC-MO for more information on critical VCTC-MO parameters including pull range linearity, absolute pull range, control voltage bandwidth, and K_v .

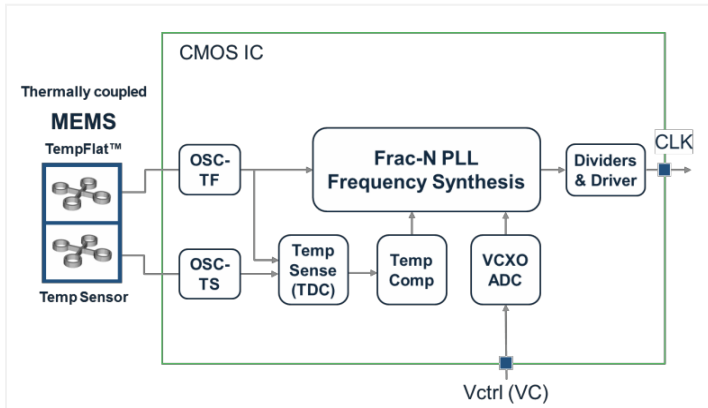

Figure 33. Block Diagram - VCTC-MO

DCTC-MO Configuration

The MO5357 offers digital control of the output frequency, as shown in Figure 34. The output frequency is controlled by writing frequency control words over the I²C interface.

There are several advantages of DCTC-MOs relative to VCTC-MOs:

- 1) Frequency control resolution as low as 5 ppt. This high resolution minimizes accumulated time error in synchronization applications.
- 2) Lower system cost – A VCTC-MO may need a Digital to Analog Converter (DAC) to drive the control voltage input. In a DCTC-MO, the frequency control is achieved digitally by register writes to the control registers via I²C, thereby eliminating the need for a DAC.
- 3) Better noise immunity – The analog signal used to drive the voltage control pin of a VCTC-MO can be sensitive to noise and the trace over which the signal is routed can be susceptible to noise coupling from the system. The DCTC-MO does not suffer from analog noise coupling since the frequency control is performed digitally through I²C.

- 4) No Frequency Pull non-linearity. The frequency pulling is achieved via fractional feedback divider of the PLL, eliminating any pull non-linearity concern which is typical of quartz based VCTCXOs. This improves dynamic performance in closed-loop operations.
- 5) Programmable Wide Pull Range – The DCTC-MO pulling mechanism is via the fractional feedback divider and is therefore not constrained by resonator pullability as in quartz based solutions. The MO5357 offers 16 frequency pull range options from ± 6.25 ppm to ± 3200 ppm, thereby giving system designers great flexibility.

Refer to Appendix 2 Design Considerations with DCTC-MO for more information on critical DCTC-MO parameters including pull range, absolute pull range, frequency output, and I²C control registers.

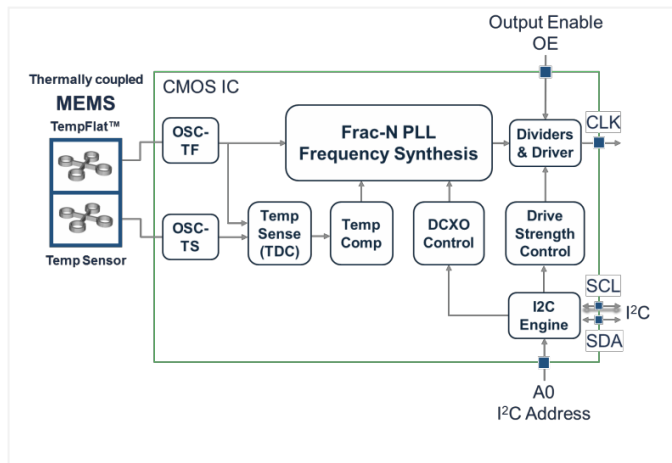

Figure 34. Block Diagram - DCTC-MO

VCTC-MO-Specific Design Considerations

Linearity

In any VCTC-MO, there will be some deviation of the frequency-voltage (FV) characteristic from an ideal straight line. Linearity is the ratio of this maximum deviation to the total pull range, expressed as a percentage. Figure 35 below shows the typical pull linearity of a KDS VCTC-MO. The linearity is excellent (1% maximum) relative to most quartz offerings because the frequency pulling is achieved with a PLL rather than varactor diodes.

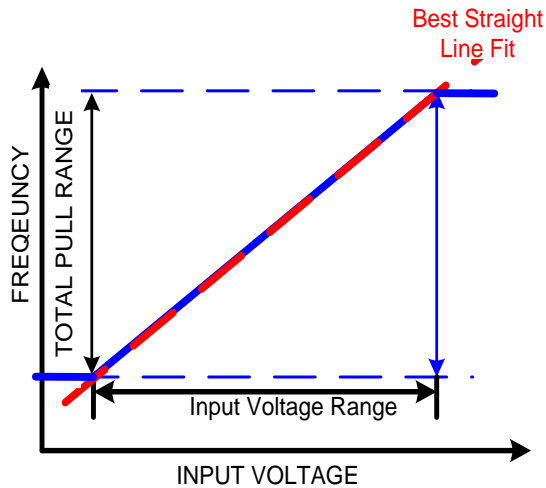

Figure 35. Typical KDS VCTC-MO Linearity

Control Voltage Bandwidth

Control voltage bandwidth, sometimes called “modulation rate” or “modulation bandwidth”, indicates how fast a VCO can respond to voltage changes at its input. The ratio of the output frequency variation to the input voltage variation, previously denoted by K_v , has a low-pass characteristic in most VCTC-MOs. The control voltage bandwidth equals the modulating frequency where the output frequency deviation equals 0.707 (e.g. -3 dB) of its DC value, for DC inputs swept in the same voltage range.

For example, a part with a ±6.25 ppm pull range and a 0-3V control voltage can be regarded as having an average K_v of 4.17 ppm/V (12.5 ppm/3V = 4.17 ppm/V). Applying an input of +1.5V DC ± 0.5V (+1.0 V to +2.0V) causes an output frequency change of 4.17 ppm (±2.08 ppm). If the control voltage bandwidth is specified as 10 kHz, the peak-to-peak value of the output frequency change will be reduced to 4.33 ppm/√2 or 2.95 ppm, as the frequency of the control voltage change is increased to 10 kHz.

FV Characteristic Slope K_v

The slope of the FV characteristic is a critical design parameter in many low bandwidth PLL applications. The slope is the derivative of the FV characteristic – the deviation of frequency divided by the control voltage change needed to produce that frequency deviation, over a small voltage span, as shown below:

$$K_v = \frac{\Delta f_{out}}{\Delta V_{in}}$$

It is typically expressed in kHz/Volt, MHz/Volt, ppm/Volt, or similar units. This slope is usually called “ K_v ” based on terminology used in PLL designs.

The extreme linear characteristic of the KDS MO5357 VCTC-MO family means that there is very little K_v variation across the whole input voltage range (typically <1%), significantly reducing the design burden on the PLL designer. Figure 36 below illustrates the typical K_v variation.

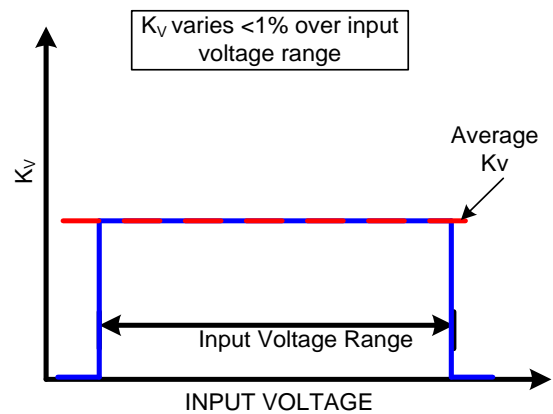

Figure 36. Typical KDS K_v Variation

Pull Range, Absolute Pull Range

Pull range (PR) is the amount of frequency deviation that will result from changing the control voltage over its maximum range under nominal conditions.

Absolute pull range (APR) is the guaranteed controllable frequency range over all environmental and aging conditions. Effectively, it is the amount of pull range remaining after taking into account frequency stability tolerances over variables such as temperature, power supply voltage, and aging, i.e.:

$$APR = PR - F_{\text{stability}} - F_{\text{aging}}$$

where $F_{\text{stability}}$ is the device frequency stability due to initial tolerance and variations on temperature, power supply, and load.

Figure 37 shows a typical KDS VCTC-MO FV characteristic. The FV characteristic varies with conditions, so that the frequency output at a given input voltage can vary by as much as the specified frequency stability of the VCTC-MO. For such VCTC-MOs, the frequency stability and APR are independent of each other. This allows very wide range of pull options without compromising frequency stability.

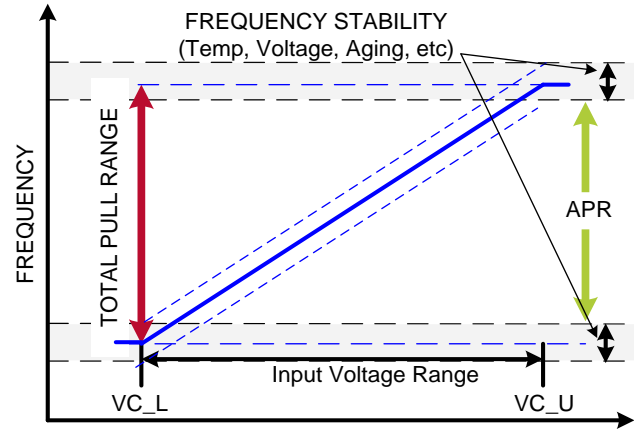

Figure 37. Typical KDS VCTC-MO FV Characteristic

The upper and lower control voltages are the specified limits of the input voltage range as shown in Figure 37 above. Applying voltages beyond the upper and lower voltages do not result in noticeable changes of output frequency. In other words, the FV characteristic of the VCTC-MO saturates beyond these voltages. Figures 1 and 2 show these voltages as Lower Control Voltage (VC_L) and Upper Control Voltage (VC_U).

Table 14 below shows the pull range and corresponding APR values for each of the frequency vs. temperature ordering options.

Table 14. VCTC-MO Pull Range, APR Options^[11] Typical unless specified otherwise. Pull range (PR) is ±6.25 ppm.

Pull Range Ordering Code	Device Option(s)	APR ppm	APR ppm	APR ppm
		±0.1 ppm option ±0.5 ppm 20-year aging	±0.2ppm option ±2 ppm 20-year aging	±0.25 ppm option ±2 ppm 20-year aging
T	VCTC-MO	±5.15	±3.05	±3.0

Notes:

11. APR includes ±1 ppm solder down shift, frequency stability vs. temperature (±0.1 ppm, ±0.2 ppm, ±0.25 ppm) and the corresponding 20-year aging.

DCTCXO-Specific Design Considerations

Pull Range and Absolute Pull Range

Pull range and absolute pull range are described in the previous section. Table 15 below shows the pull range and corresponding APR values for each of the frequency vs. temperature ordering options.

Table 15. APR Options^[12]

Pull Range Ordering Code	Pull Range ppm	APR ppm ± 0.1 ppm option ± 0.5 ppm 20-year aging	APR ppm ± 0.2 ppm option ± 2 ppm 20-year aging	APR ppm ± 0.25 ppm option ± 2 ppm 20-year aging
T	± 6.25	± 5.15	± 3.05	± 3.0
R	± 10	± 8.90	± 6.80	± 6.75
Q	± 12.5	± 11.4	± 9.3	± 9.25
M	± 25	± 23.95	± 21.8	± 21.75
B	± 50	± 48.9	± 46.8	± 46.75
C	± 80	± 78.9	± 76.8	± 76.75
E	± 100	± 98.9	± 96.8	± 96.75
F	± 125	± 123.9	± 121.8	± 121.75
G	± 150	± 148.9	± 146.8	± 146.75
H	± 200	± 198.9	± 196.8	± 196.75
X	± 400	± 398.9	± 396.8	± 396.75
L	± 600	± 598.9	± 596.8	± 596.75
Y	± 800	± 798.9	± 796.8	± 796.75
S	± 1200	± 1198.9	± 1196.8	± 1196.75
Z	± 1600	± 1598.9	± 1596.8	± 1596.75
U	± 3200	± 3198.9	± 3196.8	± 3196.75

Notes:

12. APR includes initial tolerance, frequency stability vs. temperature, and the corresponding 20-year aging.

Output Frequency

The device powers up at the nominal operating frequency and pull range specified by the ordering code. After power-up both pull range and output frequency can be controlled via I²C writes to the respective control registers. The maximum output frequency change is constrained by the pull range limits.

The pull range is specified by the value loaded in the digital pull-range control register. The 16 pull range choices are specified in the control register and range from ±6.25ppm to ±3200ppm.

Table 16 below shows the frequency resolution versus pull range programmed value

The ppm frequency offset is specified by the 26 bit DCXO frequency control register in two's complement format as described in the I²C Register Descriptions. The power up default value is 000000000000000000000000b which sets the output frequency at its nominal value (0 ppm). To change the output frequency, a frequency control word is written to 0x00[15:0] (Least Significant Word) and 0x01[9:0] (Most Significant Word). The LSW value should be written first followed by the MSW value; the frequency change is initiated after the MSW value is written.

Table 16. Frequency Resolution vs. Pull Range

Programmed Pull Range	Frequency Resolution
±6.25ppm	5x10 ⁻¹²
±10ppm	5x10 ⁻¹²
±12.5ppm	5x10 ⁻¹²
±25ppm	5x10 ⁻¹²
±50ppm	5x10 ⁻¹²
±80ppm	5x10 ⁻¹²
±100ppm	5x10 ⁻¹²
±120ppm	5x10 ⁻¹²
±150ppm	5x10 ⁻¹²
±200ppm	5x10 ⁻¹²
±400ppm	1x10 ⁻¹¹
±600ppm	1.4x10 ⁻¹¹
±800ppm	2.1x10 ⁻¹¹
±1200ppm	3.2x10 ⁻¹¹
±1600ppm	4.7x10 ⁻¹¹
±3200ppm	9.4x10 ⁻¹¹

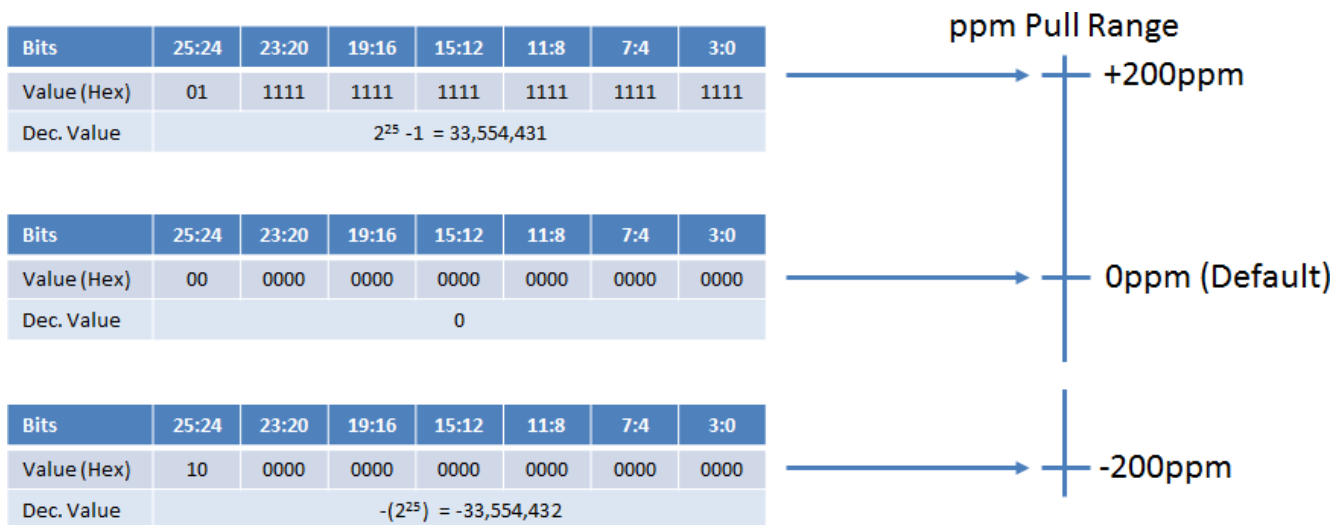

Figure 38. Pull range and Frequency Control Word

Figure 38 shows how the two's complement signed value of the frequency control word sets the output frequency within the ppm pull range set by 0x02:[3:0]. This example shows use of the ±200 ppm pull range. Therefore to set the desired output frequency, one just needs to calculate the fraction of full scale value ppm, convert to two's complement binary and then write the values to the frequency control registers.

The following formula generates the control word value:

Control word Value = RND($(2^{25}-1) * \text{ppm shift from nominal/pull range}$), where RND is the rounding function which rounds the number to the nearest whole number. Two examples follow, assuming the ±200 ppm pull range:

Example 1:

- Default Output Frequency = 98.304 MHz
- Desired Output Frequency = 98.31284736 MHz (+90 ppm)

$2^{25}-1$ corresponds to +200 ppm, and the fractional value required for +90 ppm can be calculated as follows.

■ $90 \text{ ppm} / 200 \text{ ppm} \times (2^{25}-1) = 15,099,493.95.$

Rounding to the nearest whole number yields 15,099,494 and converting to two's complement gives a binary value of 111001100110011001100110 and E66666 in hex.

Example 2:

- Default Output Frequency = 155.52 MHz
- Desired Output Frequency = 155.512224 MHz (-50 ppm)

Following the formula shown above,

■ $(-50 \text{ ppm} / 200 \text{ ppm}) \times (2^{25}-1) = -8,388,607.75.$

Rounding this to the nearest whole number results in -8,388,608.

Converting to two's complement binary results in 111000000000000000000000 and 380000 in hex.

To summarize, the procedure for calculating the frequency control word associated with a given ppm offset is as follows:

- 1) Calculate the fraction of the half pull range needed. For example, if the total pull range is set for ±100 ppm and a +20 ppm shift from the nominal frequency is needed, this fraction is 20 ppm/100 ppm = 0.2
- 2) Multiply this fraction by the full half scale word value, $2^{25}-1 = 33,554,431$, round to the nearest whole number and convert the result to two's complement binary. Following the +20ppm example, this value is $0.2 \times 33,554,431 = 6,710,886.2$ and rounded to 6,710,886.
- 3) Write the two's complement binary value starting with the Least Significant Word (LSW) 0x00[16:0], followed by the Most Significant Word (MSW), 0x01[9:0]. If the user desires that the output remains enabled while changing the frequency, a 1 must also be written to the OE control bit 0x01[10] if the device has software OE Control Enabled.

It is important to note that the maximum Digital Control update rate is 38 kHz regardless of I²C bus speed.

I²C Control Registers

The MO5357 enables control of frequency pull range, frequency pull value, and Output Enable via I²C writes to the control registers. Table 17 below shows the register map summary, and detailed register descriptions follow.

Table 17. Register Map Summary

Address	Bits	Access	Description
0x00	[15:0]	RW	DIGITAL FREQUENCY CONTROL LEAST SIGNIFICANT WORD (LSW)
0x01	[15:11]	R	NOT USED
	[10]	RW	OE Control. This bit is only active if the output enable function is under software control. If the device is configured for hardware control using the OE pin, writing to this bit has no effect.
	[9:0]	RW	DIGITAL FREQUENCY CONTROL MOST SIGNIFICANT WORD (MSW)
0x02	[15:4]	R	NOT USED
	[3:0]	RW	DIGITAL PULL RANGE CONTROL

Register Descriptions

Register Address: 0x00. Digital Frequency Control Least Significant Word (LSW)

Bit	15	14	13	12	11	10	9	8	7	6	5	4	3	2	1	0
Access	RW	RW	RW	RW	RW	RW	RW	RW	RW	RW	RW	RW	RW	RW	RW	RW
Default	0	0	0	0	0	0	0	0	0	0	0	0	0	0	0	0
Name	DIGITAL FREQUENCY CONTROL LEAST SIGNIFICANT WORD (LSW)[15:0]															

Bits	Name	Access	Description
15:0	DIGITAL FREQUENCY CONTROL LEAST SIGNIFICANT WORD	RW	<p>Bits [15:0] are the lower 16 bits of the 26 bit FrequencyControlWord and are the Least Significant Word (LSW). The upper 10 bits are in register 0x01[9:0] and are the Most Significant Word (MSW). The lower 16 bits together with the upper 10 bits specify a 26-bit frequency control word.</p> <p>This power-up default values of all 26 bits are 0 which sets the output frequency at its nominal value. After power-up, the system can write to these two registers to pull the frequency across the pull range. The register values are two's complement to support positive and negative control values. The LSW value should be written before the MSW value because the frequency change is initiated when the new values are loaded into the MSW. More details and examples are discussed in the next section.</p>

Register Address: 0x01. OE Control, Digital Frequency Control Most Significant Word (MSW)

Bit	15	14	13	12	11	10	9	8	7	6	5	4	3	2	1	0
Access	R	R	R	R	R	RW	RW	RW	RW	RW	RW	RW	RW	RW	RW	RW
Default	0	0	0	0	0	0	0	0	0	0	0	0	0	0	0	0
Name	NOT USED					OE	DCMO FREQUENCY CONTROL[9:0] MSW									

Bits	Name	Access	Description
15:11	NOT USED	R	Bits [15:10] are read only and return all 0's when read. Writing to these bits has no effect.
10	OE Control	RW	Output Enable Software Control. Allows the user to enable and disable the output driver via I ² C. 0 = Output Disabled (Default) 1 = Output Enabled This bit is only active if the Output Enable function is under software control. If the device is configured for hardware control using the OE pin, writing to this bit has no effect.
9:0	DIGITAL FREQUENCY CONTROL MOST SIGNIFICANT WORD (MSW)	RW	Bits [9:0] are the upper 10 bits of the 26 bit FrequencyControlWord and are the Most Significant Word (MSW). The lower 16 bits are in register 0x00[15:0] and are the Least Significant Word (LSW). These lower 16 bits together with the upper 10 bits specify a 26-bit frequency control word. This power-up default values of all 26 bits are 0 which sets the output frequency at its nominal value. After power-up, the system can write to these two registers to pull the frequency across the pull range. The register values are two's complement to support positive and negative control values. The LSW value should be written before the MSW value because the frequency change is initiated when the new values are loaded into the MSW. More details and examples are discussed in the previous section.

Register Address: 0x02. DIGITAL PULL RANGE CONTROL^[13]

Bit	15	14	13	12	11	10	9	6	5	6	5	4	3	2	1	0
Access	R	R	R	R	R	R	R	R	R	R	R	R	RW	RW	RW	RW
Default	0	0	0	0	0	0	0	0	0	0	0	0	X	X	X	X
Name	NONE												DIGITAL PULL RANGE CONTROL			

Notes:

13. Default values are factory set but can be over-written after power-up.

Bits	Name	Access	Description
15:4	NONE	R	Bits [15:4] are read only and return all 0's when read. Writing to these bits has no effect.
3:0	DIGITAL PULL RANGE CONTROL	RW	<p>Sets the digital pull range of the DC-MO. The table below shows the available pull range values and associated bit settings. The default value is factory programmed</p> <p>Bit</p> <p>3 2 1 0</p> <p>0 0 0 0: ±6.25ppm 0 0 0 1: ±10ppm 0 0 1 0: ±12.5ppm 0 0 1 1: ±25ppm 0 1 0 0: ±50ppm 0 1 0 1: ±80ppm 0 1 1 0: ±100ppm 0 1 1 1: ±125ppm 1 0 0 0: ±150ppm 1 0 0 1: ±200ppm 1 0 1 0: ±400ppm 1 0 1 1: ±600ppm 1 1 0 0: ±800ppm 1 1 0 1: ±1200ppm 1 1 1 0: ±1600ppm 1 1 1 1: ±3200ppm</p>

Serial Interface Configuration Description

The MO5357 includes an I²C interface to access registers that control the DCTC-MO frequency pull range, and frequency pull value. The MO5357 I²C slave-only interface supports clock speeds up to 1 MHz. The MO5357 I²C module is based on the I²C specification, UM1024 (Rev.6 April 4, 2014 of NXP Semiconductor).

Serial Signal Format

The SDA line must be stable during the high period of the SCL. SDA transitions are allowed only during SCL low level for data communication. Only one transition is allowed during the low SCL state to communicate one bit of data. Figure 39 shows the detailed timing diagram.

An idle I²C bus state occurs when both SCL and SDA are not being driven by any master and are therefore in a logic HI state due to the pull up resistors. Every transaction begins with a START (S) signal and ends with a STOP (P) signal. A START condition is defined by a high to low transition on the SDA while SCL is high. A STOP condition is defined by a low to high transition on the SDA while SCL is high. START and STOP conditions are always generated by the master. This slave module also supports repeated START (Sr) condition which is same as START condition instead of STOP condition (the blue-color line shows repeated START in Figure 40).

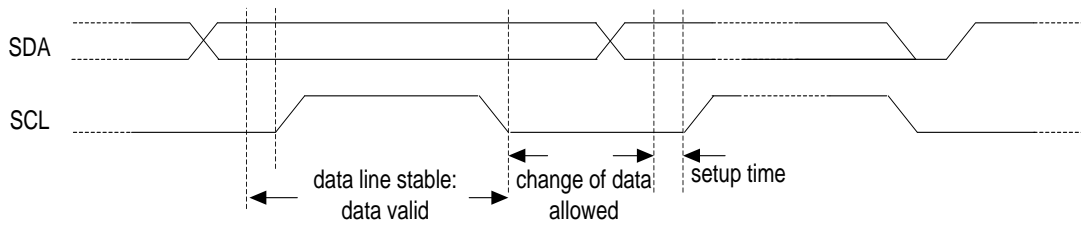

Figure 39. Data and clock timing relation in I²C bus

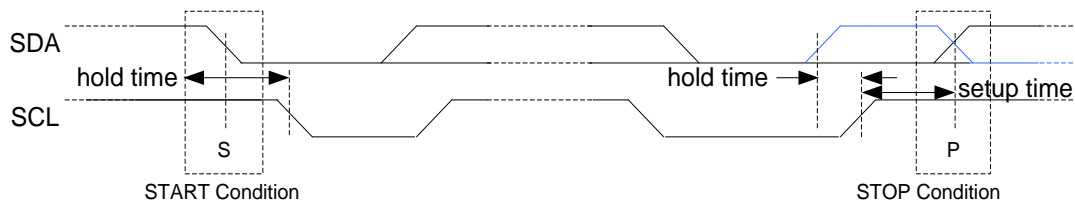

Figure 40. START and STOP (or repeated START, blue line) condition

Parallel Signal Format

Every data byte is 8 bits long. The number of bytes that can be transmitted per transfer is unrestricted. Data is transferred with the MSB (Most Significant Bit) first. The detailed data transfer format is shown in Figure 42 below.

The acknowledge bit must occur after every byte transfer and it allows the receiver to signal the transmitter that the byte was successfully received and another byte may be sent. The acknowledge signal is defined as follows: the transmitter releases the SDA line during the acknowledge clock pulse so the receiver can pull the SDA line low and it remains stable low during the high period of this clock pulse. Setup and hold times must also be taken into account. When SDA remains high during this ninth clock pulse, this is defined as the Not-Acknowledge signal (NACK). The master can then generate either a STOP condition to abort the transfer, or a repeated START condition to start a new transfer. The only condition that leads to the generation of NACK from the MO5357 is when the transmitted address does not match the slave address. When the master is reading data from the MO5357, the MO5357 expects the ACK from the master at the end of received data, so that the slave releases the SDA line and the master can generate the STOP or repeated START. If there is a NACK signal at the end of the data, then the MO5357 tries to send the next data. If the first bit of the next data is “0”, then the MO5357 holds the SDA line to “0”, thereby blocking the master from generating a STOP/(re)START signal.

Parallel Data Format

This I²C slave module supports 7-bit device addressing format. The 8th bit is a read/write bit and “0” indicates a read transaction and a “1” indicates a write transaction. The register addresses are 8-bits long with an address range of 0 to 255 (00h to FFh). Auto address incrementing is supported which allows data to be transferred to contiguous addresses without the need to write each address beyond the first address. Since the maximum register address value is 255, the address will roll from 255 back to 0 when auto address incrementing is used. Obviously, auto address incrementing should only be used for writing to contiguous addresses. The data format is 16-bit (two bytes) with the most significant byte being transferred first.

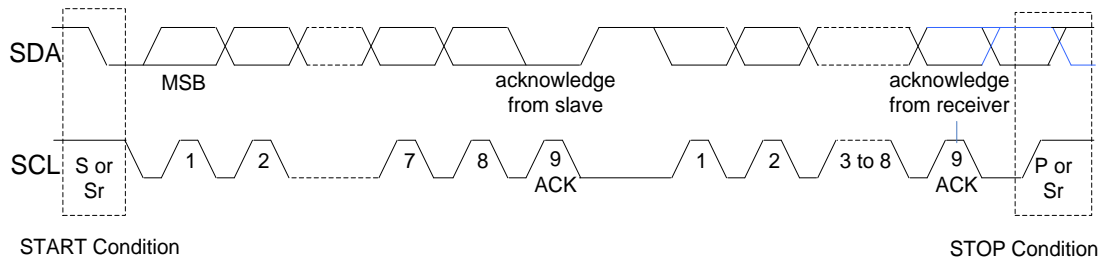

Figure 41. Parallel Signaling Format

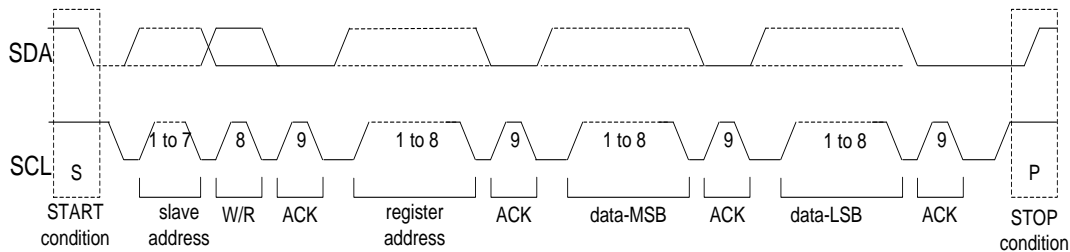

Figure 42. Parallel Data Byte Format

Figure 43 below shows the I²C sequence for writing the 4-byte control word using auto address incrementing.

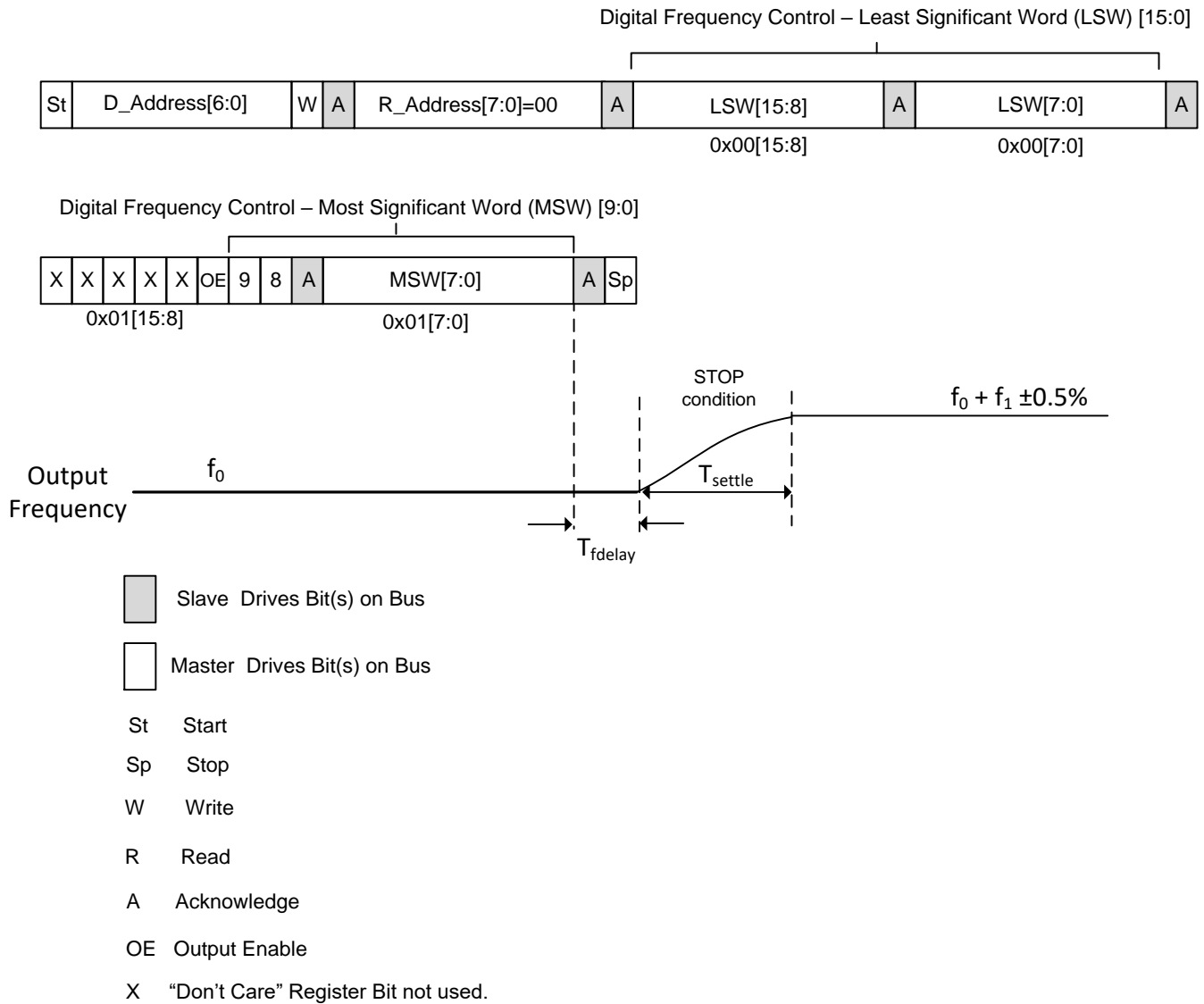

Figure 43. Writing the Frequency Control Word

Table 18. DCTC-MO Delay and Settling Time

Parameter	Symbol	Minimum	Typical	Maximum	Units	Notes
Frequency Change Delay	T_{fdelay}	–	22	–	µsec	
Frequency Settling Time	T_{settle}	–	30	–	µsec	Time to settle to 1% of final frequency value

I²C Timing Specification

The below timing diagram and table illustrate the timing relationships for both master and slave.

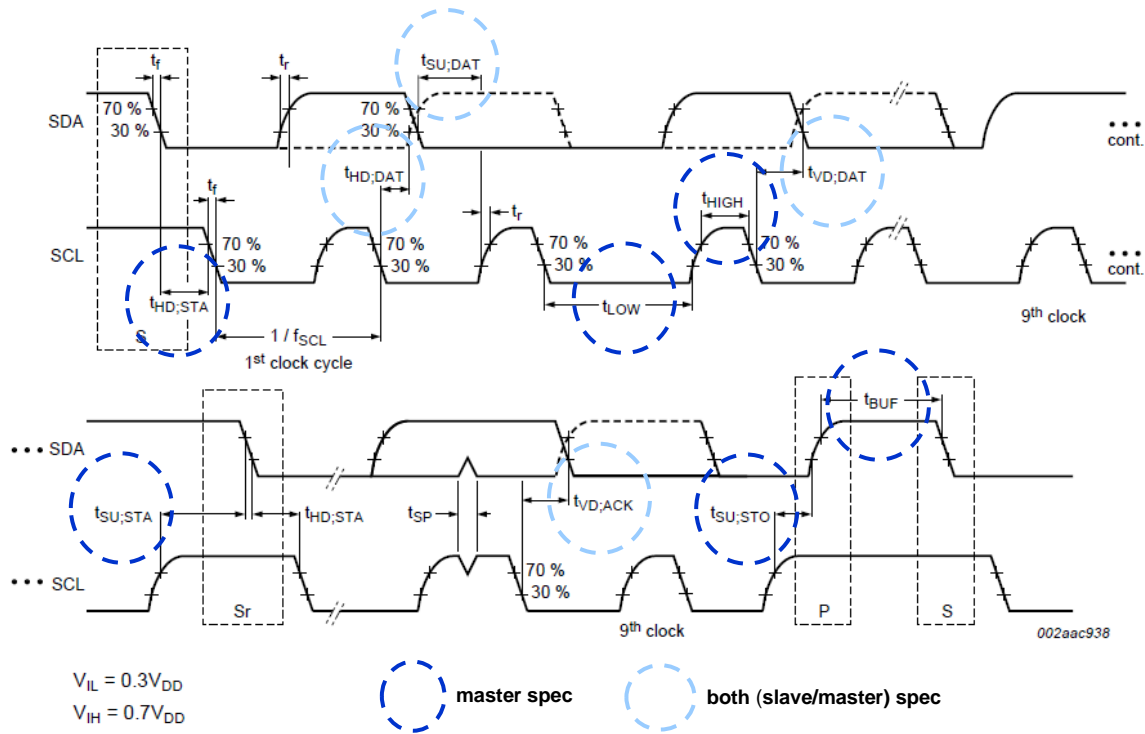

Figure 44. I²C Timing Diagram

Table 19. I²C Timing Requirements

Parameter	Speed Mode	Value	Unit
t_{SETUP}	FM+ (1 MHz)	> 50	nsec
	FM (400KHz)	> 100	nsec
	SM (100KHz)	> 250	nsec
t_{HOLD}	FM+ (1 MHz)	> 0	nsec
	FM (400KHz)	> 0	nsec
	SM (100KHz)	> 0	nsec
$t_{VD:AWK}$	FM+	> 450	nsec
	FM (400KHz)	> 900	nsec
	SM (100KHz)	> 3450	nsec
$t_{VD:DAT}$		NA (s-awk + s-data)/(m-awk/s-data)	

I²C Device Address Modes

There are two I²C address modes:

- 1) Factory Programmed Mode. The lower 4 bits of the 7-bit device address are set by ordering code as shown in Table 16 below. There are 16 factory programmed addresses available. In this mode, pin 5 is NC and the A0 I²C address pin control function is not available.
- 2) A0 Pin Control. This mode allows the user to select between two I²C Device addresses as shown in Table 21

Table 20. Factory Programmed I²C Address Control^[14]

I ² C Address Ordering Code	Device I ² C Address
0	1100000
1	1100001
2	1100010
3	1100011
4	1100100
5	1100101
6	1100110
7	1100111
8	1101000
9	1101001
A	1101010
B	1101011
C	1101100
D	1101101
E	1101110
F	1101111

Notes:

14. Table 20 is only valid for the DCTC-MO device option which supports I²C Control.

Table 21. Pin Selectable I²C Address Control^[15]

A0 Pin 5	I ² C Address
0	1100010
1	1101010

Notes:

15. Table 21 is only valid for the DCTC-MO device option which supports I²C control and A0 Device Address Control Pin.

Schematic Example

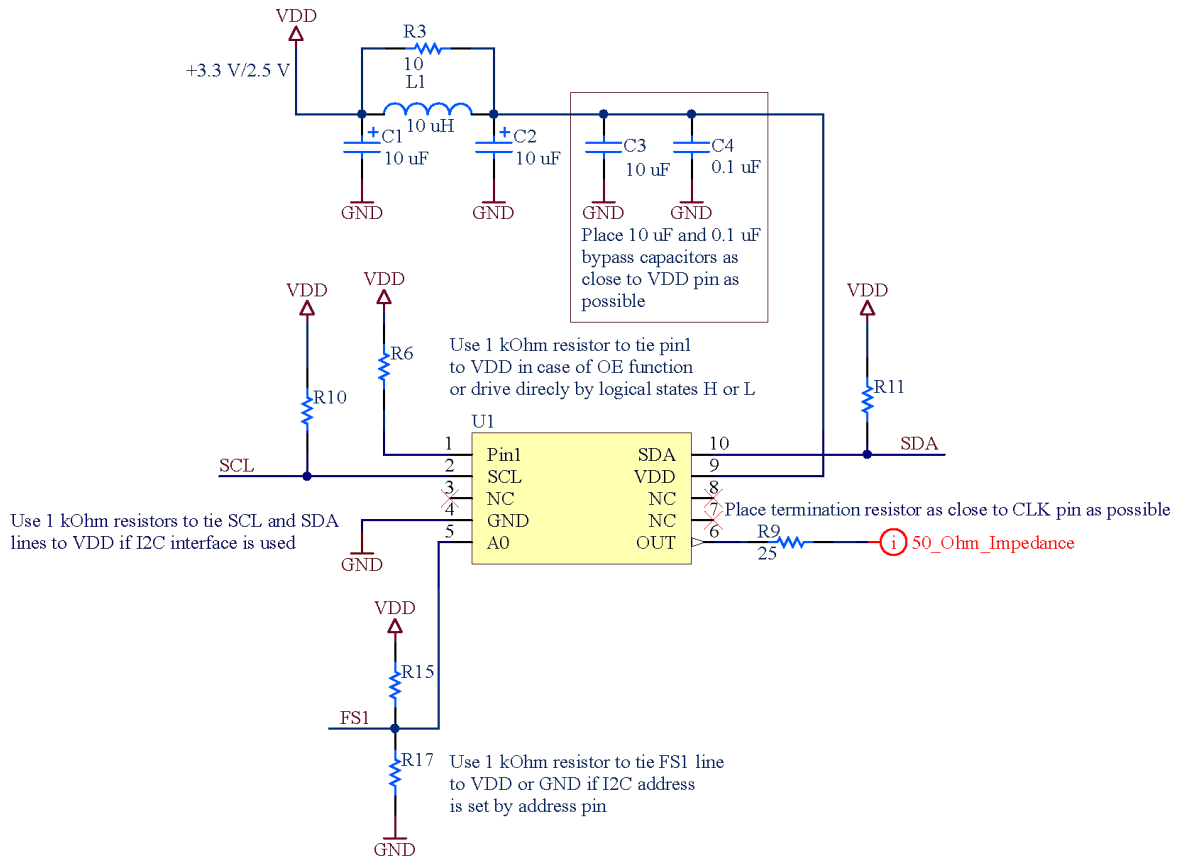

Figure 45. DCTC-MO schematic example

Dimensions and Patterns

Package Size – Dimensions (Unit: mm)

	SYMBOL	MIN	NOM	MAX	
TOTAL THICKNESS	A	0.840	0.950	1.060	
BODY SIZE	X	D	4.850	5.000	5.150
	Y	E	3.050	3.200	3.350
LEAD PITCH	e	1.070	1.200	0.330	
	e1	1.200	1.350	1.480	
	e2	0.970	1.100	1.230	
LEAD LENGTH	L	0.970	1.100	1.230	
	L1	0.770	0.900	1.030	
LEAD WIDTH	W	0.470	0.600	0.730	
	W1	0.670	0.800	0.930	
	W2	0.470	0.600	0.730	

NOTES

- Dimensioning and tolerancing conform to ASME Y14.5-2009.
- All dimensions are in millimeters.

TITLE		DWG. NO.	
10L CQFN		POD-CQFN-010-E05032-036	
3.200x5.000x0.950mm		REV.	SHEET
DATE	29-JUN-2018	A01	1 OF 1

Recommended Land Pattern (Unit: mm)

Solder Print Layout	
10L Ceramic	SPL-001-RevA
5.0x3.2x0.87	
2017/06/20	

Layout Guidelines

- MO5357 uses internal regulators to minimize the impact of the power supply noise. For further reduction of noise, it is essential to use two bypass capacitors (0.1 μ F and 10 μ F). Place the bypass capacitors as close to the Vdd as possible, typically within 1 to 2 mm. Ensure that the 0.1 μ F cap is the closest to the device Vdd and GND power pins
- It is also recommended to connect all NC pins to the ground plane and place multiple vias under the GND pin for maximum heat dissipation.
- For additional layout recommendations, contact KDS.

Manufacturing Guidelines

The MO5357 Super-TC-MOs is a precision timing device. **Preper PCB solder and cleaning proress** must be followed to ensure best performance and long-term reliability.

- **No Ultrasonic or Megasonic Cleaning:** Do not subject the MO5357 to an ultrasonic or megasonic cleaning environment. Permanent damage or long-term reliability issues to the device may occur in such an event.
- **No external cover.** Unlike legacy quartz TCXOs, the MO5357 is engineered to operate reliably without performance degradation, in the presence of ambient disturbers such as airflow and sudden temperature changes. Therefore, the use of an external cover typical of quartz TCXOs is not needed.
- **Reflow profile:** For mounting these devices to the PCB, IPC/JEDEC J-STD-020 compliant reflow profile must be used. Device performance is not guaranteed if soldered manually or with a non-compliant reflow profile.
- **PCB cleaning:** after the surface mount (SMT)/reflow process, solder flux residues may be present on the PCB and around the pads of the device. Excess residual solder flux may lead to problems such as pad corrosion, elevate leakage currents, increased frequency aging, or other performance degradation. For optimal device performance and long-term reliability, thorough cleaning and drying of the PCB is required as shortly after the reflow process as possible, even when using a “no clean” flux. Care should be taken to remove all residual flux between the KDS device and the PCB. Note that ultrasonic PCB cleaning should not be used with KDS oscillators.
- For additional manufacturing guidelines and marking/ tape-reel instructions, contact KDS.

Table 22. Revision History

Version	Release Date	Change Summary
0.1	05/10/2016	First release, advanced information
0.15	08/04/2016	Replaced QFN package with SOIC-8 package Added 10 μ F bypass cap requirement Updated test circuits to reflect both new bypass cap requirement and SOIC-8 package Update Table 1 (Electrical Characteristics)
0.16	09/12/2016	Updated test circuit diagrams
0.2	09/21/2016	Revised Table 1 (Electrical Characteristics)
0.4	12/19/2016	Added DCTC-MO mode Added I2C information Added I2C
0.5	07/21/2017	Added 5.0x3.2 mm package information Updated Table 1: Electrical Characteristics
0.51	08/20/2017	Changed to preliminary Updated 5.0x3.2 mm package dimensions Updated test circuits Updated Table 1 (Electrical Characteristics) Updated part ordering info Misc. corrections
0.52	11/24/2017	Updated the Thermal Characteristics table Added more on Manufacturing Guideline section
0.55	02/05/2018	Added View labels to Package Drawings Updated links and notes
0.60	03/01/2018	Added +105°C support, updated Ordering Information
1.0	06/26/2018	Updated Electrical Characteristics tables. Added Performance Plots. Improved readability. Fixed bad hyperlinks.
1.01	07/03/2018	Updated I ² C specifications, Table 3 (Input Characteristics)
1.02	07/04/2018	Updated Mechanical Shock Resistance, Table 9 (Environmental Compliance)
1.03	08/02/2018	Revised phase noise specification. Updated package outline drawing. Updated conditions for one day and one year aging specs. Various formatting updates.