

## SMD Crystal Oscillators

### DS1008JS

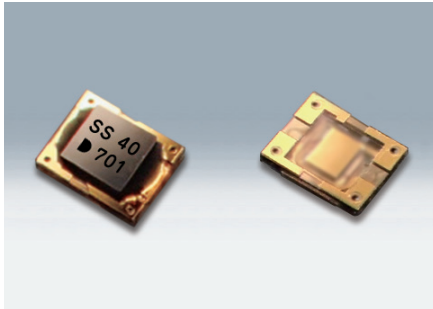

Actual size ◻

#### ■ Features

- 1008 size, height 0.24mm max. Unprecedented extremely low-profile package using a novel structure
- Available frequency range : 1 to 100MHz
- Supply Voltage : +1.8V to +3.3V
- 3-state function
- Available up to 100MHz by using AT cut fundamental resonator. Low jitter provides for high performance.



#### ■ Applications

- Mobile communications and short-range wireless modules
- Wearable devices
- Automotive multimedia device

#### ■ Standard Specification

Item	Type	Legend	Spec.			Unit	Condition	
			min.	typ.	max.			
Frequency Range		$f_0$	1	–	100	MHz		
Supply Voltage		Vcc	+1.6	–	+3.6	V		
Frequency Tolerance (Includes frequency tolerance at room temperature.)		$f_{tol}$	-100	–	+100	$\times 10^{-6}$	-40 to +125°C	-20 to +70°C (Standard Operating Temperature Range)
			-50	–	+50			
			-30	–	+30		-30 to +85°C	
			-20	–	+20			
Current Consumption		Icc	–	–	1.8	mA	$f_0=24\text{MHz}$ , Vcc=+1.8V, No Load	
Stand-by Current (#1 pin "L" Level)		L_std	–	–	0.01	mA		
Load Condition		L_cmos	–	–	15	pF		
Symmetry		SYM	45	50	55	%	at 50% Vcc, $f_0 < 60\text{MHz}$	
Rise and Fall Time		tr, tf	–	–	5	ns	10 to 90% Vcc Level	
Output Enable Time		tPZL	–	–	2	ms		
Output Disable Time		tPLZ	–	–	200	ns		
OE Pin 1 Level Input Voltage		V <sub>IH</sub>	Vcc $\times 0.8$	–	–	V		
OE Pin 0 Level Input Voltage		V <sub>IL</sub>	–	–	Vcc $\times 0.2$	V		
Packing Unit (1)							3000pcs./reel ( $\phi 180$ )	

(1) Moisture prevention packing

Consult our sales representative for other specifications

[mm]

#### ■ Dimensions

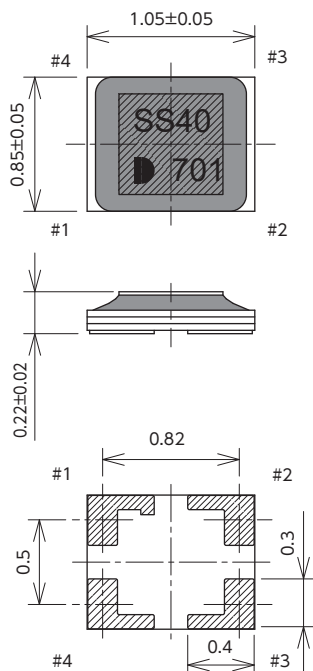

#### Pin Connection

Pin No.	Connection
#1	OE (Output Enable)
#2	GND
#3	Output
#4	Vcc

#### Function

#1 input	#3 Output condition
H	Oscillation out
Open	Oscillation out
L	High Z

#### ■ Recommended Land Pattern

(Top View)

