

# SMD Crystal Resonators / MHz Band Crystal Resonators

## DX1008JT

**NEW**

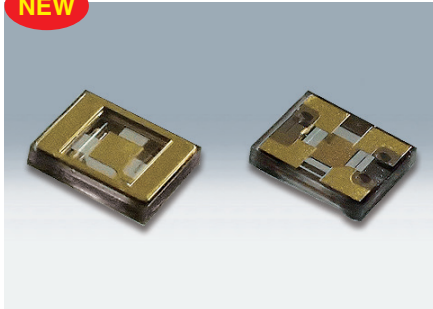

### ■ Features

- 1008 size, height 0.18mm  
Unprecedented extremely low-profile package using a novel structure
- Composed only of quartz crystal plates and metallic films without the use of a ceramic base
- Long-term high resistance to aging, due to avoiding the use of an organic conductive adhesive

### ■ Applications

- Mobile communications and short-range wireless modules
- Wearable devices
- Automotive multimedia devices



### ■ Standard Specification

Item	Type	DX1008JT	
Frequency Range		59.97MHz	76.8MHz
Overtone Order		Fundamental	
Load Capacitance		5pF, 8pF, 10pF, 12pF	
Drive Level		10μW (100μW max.)	
Frequency Tolerance		±20×10 <sup>-6</sup>	
Series Resistance		60Ω max.	50Ω max.
Frequency Characteristics over Temperature		±30×10 <sup>-6</sup> / -30 to +85°C (Ref.To 25°C)	
Storage Temperature Range		-40 to +85°C	
Packing Unit (1)		3000pcs./reel (φ180)	

(1) Moisture prevention packing is unnecessary.  
Moisture Sensitivity Level: LEVEL1 (IPC/JEDEC J-STD-033)

Consult our sales representative for other specifications

[mm]

### ■ Dimensions

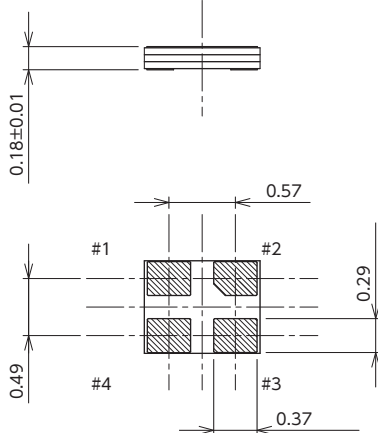
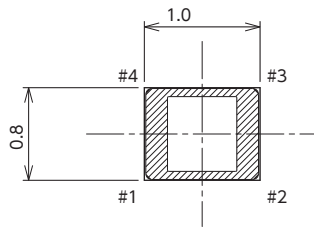

### ■ Internal Connections

〈Top View〉

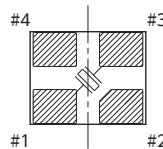

Pin Connection

Pin No.	Connection
#1	Xtal
#2	GND
#3	Xtal
#4	GND

### ■ Recommended Land Pattern

〈Top View〉

