

PRODUCT CATALOG

Arkh. series

Crystal resonators

Crystal oscillators

Monolithic crystal filters

MEMS oscillators

Global Quality

株式会社 **大真空**

INDEX

- Handling Instructions 1
- RoHS/ELV Compliant and Lead - free products 2
- How a quartz crystal device is made 3
- About this catalog 4
- Selection Guide 5

Atkh Series

- Summary 12
- SMD Crystal Resonators / MHz Band Crystal Resonators
 - DX1008JS 13
 - DX1008JT 14
- SMD Crystal Oscillators
 - DS1008JN 15
 - DS1008JS 16
 - DS2016AS/DS2520AS 17
- SMD Differential Output Crystal Oscillators
 - DS1008JC/DS1008JK/DS1008JJ 18
 - DS2016AK/DS2520AK/DS3225AK/DS2016AJ/
DS2520AJ/DS3225AJ/DS2016AD/DS2520AD/
DS3225AD 19
- High-precision SMD TCXO
 - DA2016AS/DB2016AS 20

Crystal Resonators

- Summary
 - Description, Terminology 22
 - Oscillation Circuit 23
 - Cut Angle and Frequency Characteristics over
Temperature 25
- SMD Crystal Resonators / MHz Band Crystal Resonators
 - DSX1210A 26
 - DSX1612S 27
 - DSX211S/DSX211SH/DSX221SH/DSX321SH 28
 - DSX211G 29
 - DSX321G 30
- SMD Crystal Resonators with dedicated temperature sensor /
MHz Band Crystal Resonators
 - DSR1210ATH/DSR1612ATH 31
 - DSR211STH/DSR221STH 32
- SMD Tuning Fork Crystal Resonators / kHz Band Crystal
Resonators
 - DST1210A 33
 - DST1610A/DST210AC 34
 - DST310SA 35

Crystal Oscillators

- Summary
 - Description, Terminology 38
- Temperature Compensated Crystal Oscillators [TCXO]
 - DSB1612SEB 39
 - DSA1612SDN/DSA211SDN/DSA221SDN/DSA321SDN,
DSB1612SDN/DSB211SDN/DSB221SDN/DSB321SDN 40
 - DSA535SGA/DSB535SGA/DSA535SGB 42
 - DSB211SJA/DSB221SJA 43
 - DSK1612ATD 44
- Real Time Clock Module [RTC]
 - DD3225TS 45
 - DD3225TR 46
- Simple Packaged Crystal Oscillators [SPXO]
 - DSO221SH/DSO321SH 47
 - DSO221SHH 48
 - DSO321SHH 49
 - DSO1612AR 50
 - DSO211SXF/DSO221SXF 51
 - DSO221SR/DSO321SR/DSO531SR/DSO751SR 52
 - DSO321SRS 54
 - DSO221SBM/DSO321SBM/DSO531SBM/DSO751SBM 55
 - DSO1612AR (kHz) 56
 - DSO221SY/DSO321SY 57
 - DSO223SK/DSO323SK/DSO223SJ/DSO323SJ/
DSO223SD/DSO323SD 58
 - DSO323SJ/DSO323SD (Low Voltage) 59
 - DSO533SK/DSO533SJ 60
 - DSO753SK/DSO753SJ/DSO753SD 61
 - DLO555MBA 62
- Voltage Controlled Crystal Oscillators [VCXO]
 - DSV221SV/DSV321SV 63

For Automotive

- DSX1210A 66
- DSX1612S 67
- DSX211G/DSX210GE 68
- DSX321G/DSX321GK/DSX320GE 69
- DSX530GA 70
- DSX211SH/DSX221SH/DSX321SH 71
- DSR1612ATH/DSR211STH/DSR221STH 72
- DST1610A/DST210AC/DST310SA 73
- DSO221SHH 74
- DSO1612AR 75
- DSO221SR/DSO321SR 76
- DSO211SX/DSO221SX 77
- DSO221SR/DSO321SR (kHz) 78
- DSO221SY/DSO321SY 79
- DSO223SK/DSO323SK/DSO223SJ/DSO323SJ/
DSO223SD/DSO323SD 80
- DSO323SJ/DSO323SD (Low Voltage) 81
- DSA211SP/DSB211SP 82
- DSB1612SEB 83
- DSA1612SDN/DSA211SDN/DSA221SDN/DSA321SDN,
DSB1612SDN/DSB211SDN/DSB221SDN/DSB321SDN 84
- DSB211SJA 86
- DSK1612ATD 87
- DSK321STD 88
- DD3225TS 89

Monolithic Crystal Filters

- Summary
 - Description, Terminology 92
- SMD Monolithic Crystal Filters
 - DSF334S 2POLE/DSF334S 3POLE/DSF444S 2POLE/
DSF444S 3POLE 93
 - DSF633S 2POLE/DSF633S 4POLE 94
 - DSF753S 2POLE/DSF753S 3POLE/DSF753S 4POLE 95

MEMS Oscillators

- 32 kHz MEMS Oscillators / 32 kHz TC-MO
 - MO1532/MO1552/MO1630/MO1566/
MO1568 (µPower) 98
- MEMS Oscillators / TC-MO
 - MO1534/MO1569/MO1576/MO8021 (µPower) 99
- MEMS Oscillators
 - MO9365/MO9366/MO9367 (Super Low Jitter) 100
 - MO9120/MO9121/MO9122/MO8208/
MO8209 (Low Jitter) 101
- TC-MO / VC TC-MO
 - MO5155/MO5156/MO5157/MO5356/MO5357/
MO5358/MO5359 (Super Low Jitter) 102
- MEMS Oscillators with Spread Spectrum Function [SSCG]
 - MO9005 103
- Dimensions / Land Pattern 104

Taping Forms, etc.

- Taping 108
- Measurement Circuit (Crystal Oscillators) 112
- Measurement Circuit (MEMS Oscillators) 115
- Substitution Products 116
- Product introduction on the Web 117
- KDS Global Network 121

Scan the QR code to access the model index page on our website.

Crystal Resonators



Crystal Oscillators



Monolithic Crystal Filters



MEMS Oscillators



Handling Instructions

■ Soldering

Our products are designed so they may withstand the same standard reflow soldering temperatures as most other electronics components. However, if the reflow temperature is higher than our specification allows, the performance may be affected. Avoid soldering the product at temperatures higher than specified.

For the reflow temperature profile of SMD products, refer to the figure below.

①	Preheat	160 to 180°C	120sec.
②	Primary heat	220°C	60sec
③	Peak	260°C	10sec. max.

※ The reflow temperature profile may vary depending on the product model, specifications and frequency range. Refer to the individual product specifications for details.

Reflow Temperature Profile
(Available for lead free soldering)

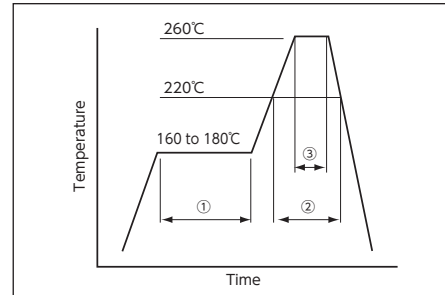

■ Cleaning

- General cleaning solutions or ultrasonic cleaning may be used to clean our crystal products, but verification tests are recommended prior to use.
- Tuning fork crystals resonate at frequency bands that are close to the washing frequency of ultrasonic cleaning machines and this may cause resonance deterioration in the crystal. Therefore the use of ultrasonic cleaning machines to clean tuning fork crystals should be avoided. After applying ultrasonic cleaning, the functionality of crystals should be verified by testing the performance of the end product.

■ Shock

Crystal products are designed to resist shock, but if the products receive excessive shocks or are dropped on the ground, be sure to check for any damages before using.

■ Mounting

<SMD crystal products>

Surface mount crystals are designed to be compatible with most automatic mounting processes, but some processes may exert excessive shock which may damage the crystal. Therefore test mounting of the crystal prior to mass production is necessary. If there is a possibility that PCB may be warped, make sure the warping is not to such a degree that the crystal products' operating characteristics or soldering conditions will be negatively affected. Avoid mounting and processing by Ultrasonic welding because this method has a possibility of an excessive vibration spreading inside the crystal products and becoming the cause of characteristic deterioration and not oscillating.

<Lead type>

When bending, forming, or mounting leaded crystal products be careful not to put too much pressure on the glassed part of the base, as it may crack and negatively affect the crystals' performance.

■ Storage

Storing crystal products at high temperatures or high humidity may deteriorate the soldering condition of pins. Do not store in direct sunlight or damp environments.

■ Others

<Crystal Resonators>

- When excessive voltage is applied to crystal resonators, their performance may be affected or the crystal blank may be damaged. When handling the product, use the product within the specifications provided.
- Negative resistance determines the tolerance margin of a circuit that oscillates the resonator. We recommend that the negative resistance be at least five times the standard series resistance for standard applications.

<Crystal Oscillators>

- C-MOS is used for internal circuit of crystal oscillators. To prevent latch-up phenomena or static electricity, take careful note.
- Some crystal oscillators do not have internally connected bypass capacitors. When using the product, use a capacitor with a good high frequency characteristic of 0.01μ F between Vcc and GND (e.g. Ceramic chip capacitor) and connect it at the shortest possible distance. For details, refer to the specifications of each individual product.

<Monolithic Crystal Filters>

- Take care so that the input pin and the output pin do not close on the PCB.
- If the floating capacity of a PCB (on which a crystal filter is to be mounted) is too large, circuit tuning may be required to cancel out the excess floating capacity.
- When excessive voltage is applied to crystal filters, their performance may be affected or the crystal blank may be damaged. When handling the product, use at its input level equal to or less than -10dBm.

RoHS/ELV Compliant Lead-free and Halogen-free products from KDS.

KDS is fully committed to environmental protection and has been proactively working to comply with the major environmental regulations such as RoHS Directive (Directive of the Restriction of the use of certain Hazardous Substances : 2011/65/EU and (EU) 2015/863), ELV Directive (End-of-Life Vehicles Directive : 2000/53/EC) and Halogen-free activities etc. The below spreadsheet provide the current status of the product compliance in each environmental regulations. Please visit our website for the latest information.(<https://www.kds.info>)

As of sept.30.2024

	Type	RoHS/ELV Compliant	Halogen-free	Pb-free	Materials of pin	Note
Crystal Resonators/ MHz Band Crystal Resonators	DX1008J SERIES	○	○	○	Ni/Au	
	DSX1210A	○	○	○	Ni/Au	
	DSX1612S	○	○	○	Ni/Au	
	DSX211S, DSX211SH	○	○	○	Ni/Au	
	DSX221SH	○	○	○	Ni/Au	
	DSX321SH	○	○	○	Ni/Au	
	DSX210GE	○	○	Pb in sealing-glass	Ni/Au	Pb in sealing-glass is exempted from RoHS/ELV Directive. ^(*)
	DSX320GE	○	○	Pb in sealing-glass	Ni/Au	Pb in sealing-glass is exempted from RoHS/ELV Directive. ^(*)
	DSX211G	○	○	Pb in sealing-glass	Ni/Au	Pb in sealing-glass is exempted from RoHS/ELV Directive. ^(*)
	DSX321G, DSX321GK	○	○	Pb in sealing-glass	Ni/Au	Pb in sealing-glass is exempted from RoHS/ELV Directive. ^(*)
Tuning Fork Crystal Resonators/ kHz Band Crystal Resonators	DSX530GA	○	○	Pb in sealing-glass	Ni/Au	Pb in sealing-glass is exempted from RoHS/ELV Directive. ^(*)
	DST1210A	○	○	○	Ni/Au	
	DST1610A	○	○	○	Ni/Au	
	DST210AC	○	○	○	Ni/Au	
Crystal Resonators with dedicated temperature sensor/ MHz Band Crystal Resonators	DST310SA	○	○	○	Ni/Au	
	DSR1210ATH	○	○	○	Ni/Au	
	DSR1612ATH	○	○	○	Ni/Au	
	DSR211STH	○	○	○	Ni/Au	
Temperature Compensated Crystal Oscillators (TCXO)	DSR221STH	○	○	○	Ni/Au	
	DA/DB2016AS	○	○	○	Ni/Au	
	DSA/DSB1612 SERIES	○	○	○	Ni/Au	
	DSA/DSB211 SERIES	○	○	○	Ni/Au	
	DSA/DSB221 SERIES	○	○	○	Ni/Au	
	DSA/DSB321 SERIES	○	○	○	Ni/Au	
	DSA/DSB535 SERIES	○	○	○	Ni/Au	
Real Time Clock Module (RTC)	DSK1612ATD	○	○	○	Ni/Au	
	DSK321STD	○	○	○	Ni/Au	
Simple Packaged Crystal Oscillators (SPXO)	DD3225TS, DD3225TR	○	○	○	Ni/Au	
	DS1008J SERIES	○	○	○	Ni/Au	
	DS2016A SERIES	○	○	○	Ni/Au	
	DS2520A SERIES	○	○	○	Ni/Au	
	DS3225A SERIES	○	○	○	Ni/Au	
	DSO1612AR	○	○	○	Ni/Au	
	DSO211S SERIES	○	○	○	Ni/Au	
	DSO221S SERIES	○	○	○	Ni/Au	
	DSO223S SERIES	○	○	○	Ni/Au	
	DSO321S SERIES	○	○	○	Ni/Au	
	DSO323S SERIES	○	○	○	Ni/Au	
	DSO531S SERIES	○	○	○	Ni/Au	
	DSO533 SERIES	○	○	○	Ni/Au	
	DLO555MBA	○	○	○	Sn	
	DSO751S SERIES	○	○	○	Ni/Au	
DSO753S SERIES	○	○	○	Ni/Au		
Voltage Controlled Crystal Oscillators (VCXO)	DSV221SV	○	○	○	Ni/Au	
	DSV321S	○	○	○	Ni/Au	
Monolithic Crystal Filters	DSF334 SERIES	○	○	○	Ni/Au	
	DSF444 SERIES	○	○	○	Ni/Au	
	DSF633 SERIES	○	○	○	Ni/Au	
	DSF753 SERIES	○	○	○	Ni/Au	

* RoHS Directive and ELV Directive exemptions are granted for high temperature solder, lead content in low-melting glass of DSX-G Series.

How a quartz crystal device is made

The piezoelectric effect

In 1880, the Curie brothers, both physicists of France (the wife of Pierre, the younger Curie, was Madame Curie (Marie), famed for her discovery of radium), discovered the phenomenon of electric polarization as a result of applying mechanical strain to a plate of quartz crystal. This effect, referred to as the “piezoelectric effect,” is an important phenomenon used in quartz crystal devices.

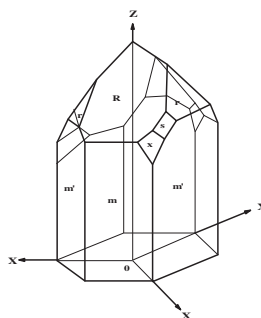

Fig. 1. Typical appearance of a quartz crystal

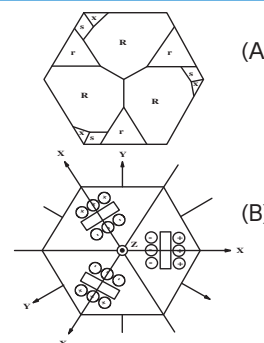

Fig. 2. (A) Typical crystallogram as obtained by viewing Fig. 1 from above
(B) Illustration of piezoelectricity

Growth of artificial quartz crystal

A quartz crystal device is produced from artificial quartz crystal; the reason for this is that artificial quartz crystal of high purity can be obtained on an industrial and stable basis, and that artificial quartz crystal can be processed into shapes suitable for further processing. Quartz crystal is grown in a special-steel oven, called an autoclave (shown in Fig. 4), under high-temperature and high-pressure conditions; this process takes several months. The natural quartz crystal that is recrystallized by means of hydrothermal synthesis is artificial quartz crystal.



Artificial quartz crystal drawn from an autoclave

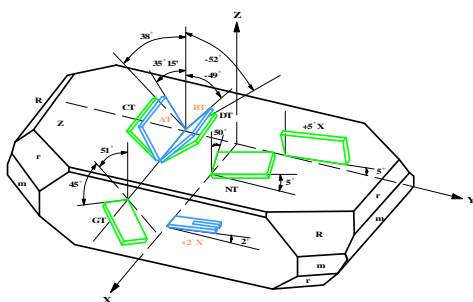

Fig.3. Designations of cuts from a piece of artificial quartz crystal

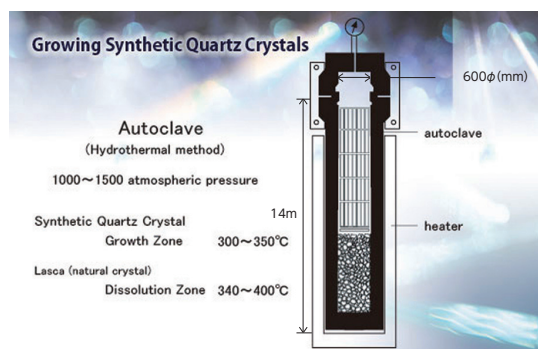
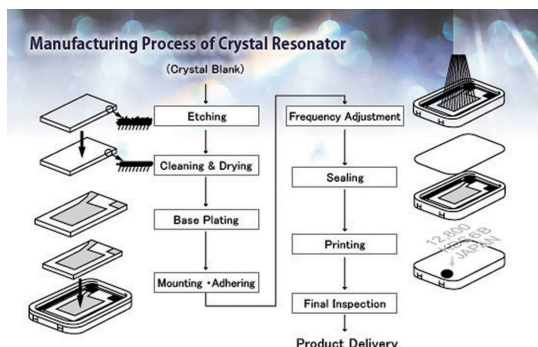
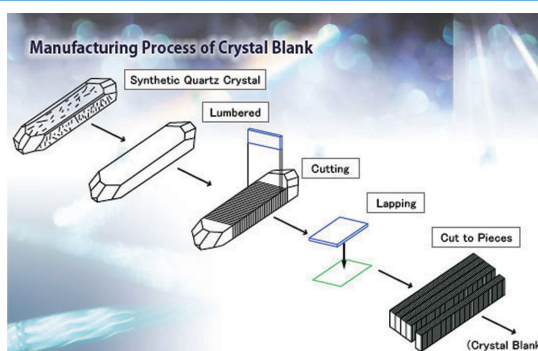

Fig.4. Autoclave

Process of manufacturing quartz crystal devices

A finished artificial quartz crystal is cut at an angle suited to its application; repeated grinding and cutting then turn it into a quartz crystal piece (a small plate-like chip of quartz crystal, it is usually called “Crystal blank”). The manufacture of a crystal blank is so important a process as to allow this crystal blank to practically determine the characteristic of a quartz crystal.

Several months after artificial crystal growth begins, the assembly process finally occurs. After the crystal surface has been cleaned, metal thin film is created on it to obtain a conductive surface, and the package is connected to the crystal blank. The crystal blank then undergoes final frequency adjustment and is packaged in a vacuum or in a nitrogen atmosphere to protect it from oxygen, moisture, and similar substances, which can affect it adversely. When all these steps have been completed, the crystal blank undergoes shipping inspection, is marked and then shipped.



Refer to "Handbook of Quartz Crystal Device, 5th ed. (QIAJ)" for each figure.

Symbols used in the catalog

As of sept.30.2024



Ark Series

A logo representing Ark Series



Ark Series



A logo representing "Slim×Small×Smart" Crystal (Triple-S Crystal) used for below-2016-size crystal devices



No lead content.
Lead-free mounting is possible.



RoHS "2011/65/EU and (EU) 2015/863" Compliant



RoHS "2011/65/EU and (EU) 2015/863"
ELV "2000/53/EC" Compliant

Environment preservation

ISO14001

Daishinku's domestic and international production sites have acquired ISO14001, an environmental management system, as one of the approaches to protect the environment.

ISO9001, IATF16949

In order to meet customer's needs with "reliance" and "reassurance", Daishinku has achieved ISO9001, IATF16949 certification in domestic and international production sites *.

*Except for Kanzaki Plant

● Use this Catalog with the following points in mind.

- The contents of this Catalog are subject to change without notice.
- It is strictly forbidden to reprint or reproduce this Catalog, either wholly or in part, without the permission of the manufacturer.
- The application circuits, methods and drawings included in this Catalog are provided strictly for the purposes of reference. Verify before using. The manufacturer is not liable if any third party has its rights infringed or incurs losses in connection with the information presented in this Catalog. Permission is neither given nor implied to exercise the industrial property rights of the manufacturer or any third party.

● Handle products carefully.

The products listed in this Catalog are intended for use with ordinary electronic devices. When a product is required to have especially high reliability in a given application, consult our sales representative.

Selection Guide



Scan the QR code to check the table of contents page of our web site "Crystal Resonators" (URL: <https://www.kds.info/class/1-l-qr/>).

Icons **CE** Consumer Equipment **IE** Industrial Equipment **TC** Mobile Phone, Wireless Communication **AE** Automotive Electronics

SMD Crystal Resonators / MHz Band Crystal Resonators

Type	Actual Size	Size (mm)			Frequency Range (MHz)	Frequency Tolerance ($\times 10^{-6}$) @+25°C	Frequency Characteristics over Temperature ($\times 10^{-6}$)	Operating Temperature Range (°C)	Load Capacitance (pF)	Drive Level ($\mu\text{w(max.)}$)	Lid	Recommended Application	Catalog Page
		L	W	H (max.)									
DX1008JS		1.05	0.85	0.13	48 to 120	± 20	± 30	-30 to +85	8, 10, 12	10 (100)	Crystal	CE TC	13
DX1008JT		1.0	0.8	0.19	59.97, 76.8	± 10	± 12	-30 to +85	5, 8, 10, 12	10 (100)	Crystal	TC	14
DSX1210A		1.2	1.0	0.3	32 to 80	± 10	± 12 ± 30	-30 to +85 -40 to +105	8, 10, 12	10 (100)	Metal	CE TC AE	26 66
DSX1612S		1.6	1.2	0.4	24 to 54	± 10	± 15 ± 30	-30 to +85 -40 to +125	8, 10, 12	10 (100)	Metal	CE TC AE	27
DSX211S		2.0	1.6	0.5	76.8, 80, 96	± 20	± 30	-30 to +85	8, 10, 12	10 (400)	Metal	CE IE TC	28
DSX211SH		2.0	1.6	0.5	16 to 60	± 20 ± 30	± 30 ± 100	-30 to +85 -40 to +125	8, 10, 12	10 (100)	Metal	CE IE TC	28 71
DSX221SH		2.5	2.0	0.5	12 to 54					10 (200)			
DSX321SH		3.2	2.5	0.75	12 to 50					10 (200)			
DSX210GE		2.2	1.6	1.0	16 to 64	± 30	± 100	-40 to +125	8, 10, 12	10 (100)	Ceramic	AE	68
DSX211G		2.0	1.6	0.8	20 to 64	± 20 ± 30	± 30 ± 100	-30 to +85 -40 to +125	8, 10, 12	10 (100)	Ceramic	CE IE TC AE	29 68
DSX320GE		3.2	2.5	1.1	7.9 to 64	± 30	± 100	-40 to +125	8, 10, 12	10 (200)	Ceramic	AE	69
DSX321G		3.2	2.5	0.9	12 to 64	± 20 ± 30	± 30 ± 100	-30 to +85 -40 to +125	8, 10, 12	10 (200)	Ceramic	CE IE TC AE	30 69
		3.2	2.5	1.0	7.9 to 12								
DSX321GK		3.2	2.5	1.0	9.8 to 40	± 30	± 100	-40 to +125	8, 10, 12	10 (200)	Ceramic	AE	69
DSX530GA		5.0	3.2	1.2	7 to 54	± 30	± 100	-40 to +125	8, 10, 12	10 (300)	Ceramic	AE	70

SMD Crystal Resonators with dedicated temperature sensor / MHz Band Crystal Resonators

Type	Actual Size	Size (mm)			Frequency Range (MHz)	Frequency Tolerance ($\times 10^{-6}$) @+25°C	Frequency Characteristics over Temperature ($\times 10^{-6}$)	Operating Temperature Range (°C)	Load Capacitance (pF)	Drive Level ($\mu\text{w(max.)}$)	Lid	Recommended Application	Catalog Page
		L	W	H (max.)									
DSR1210ATH		1.2	1.0	0.55	76.8	± 10	± 12	-30 to +85	6, 7, 8	10 (100)	Metal	TC	31
DSR1612ATH		1.6	1.2	0.65	38.4, 52, 76.8 38.4	± 10	± 12 ± 30	-30 to +85 -40 to +105	6, 7, 8 7, 8	10 (100)	Metal	TC AE	31 72
DSR211STH		2.0	1.6	0.8 (0.65)	19.2, 26, (38.4, 55.2) 19.2, (38.4, 55.2)	± 10	± 12 ± 30	-30 to +85 -40 to +105	6, 7, 8 7, 8	10 (100)	Metal	TC AE	32 72
DSR221STH		2.5	2.0	1.0	19.2, 26 19.2	± 10	± 12 ± 20	-30 to +85 -40 to +105	6, 7, 8 7, 8	10 (100)	Metal	TC AE	

SMD Tuning Fork Crystal Resonators / kHz Band Crystal Resonators

Type	Actual Size	Size (mm)			Frequency Range (kHz)	Frequency Tolerance ($\times 10^{-6}$) @+25°C	Series resistance (k Ω max.)	Operating Temperature Range (°C)	Load Capacitance (pF)	Drive Level ($\mu\text{w(max.)}$)	Package	Recommended Application	Catalog Page
		L	W	H (max.)									
DST1210A		1.25	1.05	0.35	32.768	± 20	80	-40 to +85	7, 9, 12.5	0.1 (0.2)	Ceramic	CE TC	33
DST1610A		1.6	1.0	0.5	32.768	± 20	50/80 120	-40 to +85 -40 to +125	4, 6, 7, 9, 12.5	0.1 (0.5)	Ceramic	CE TC AE	34 73
DST210AC		2.0	1.2	0.55			50/80 120	-40 to +85 -40 to +125	6, 7, 9, 12.5				
DST310SA		3.2	1.5	0.85	32.768	± 20	50 80	-40 to +85 -40 to +125	6, 7, 9, 12.5	0.1 (0.5)	Ceramic	CE IE TC AE	33 73

Selection Guide



Scan the QR code to check the table of contents page of our web site "Crystal Oscillators" (URL: <https://www.kds.info/class/2-l-co/>).

Icons **VC** Voltage Control Function **Stb** Stand-by Function
CE Consumer Equipment **IE** Industrial Equipment **TC** Mobile Phone, Wireless Communication **AE** Automotive Electronics

Temperature Compensated Crystal Oscillators (TCXO/VC-TCXO)

Type	Actual Size	Size (mm)			Output	Frequency Range (MHz)	Frequency Characteristics over Temperature ($\times 10^{-6}$)	Operating Temperature Range (°C)	Supply Voltage (V)	Function	Recommended Application	Catalog Page
		L	W	H (max.)								
DA2016AS		2.0	1.6	0.8	CS	26, 52	± 1.0 ± 0.5	-40 to +85	+1.68 to +3.5	VC	IE TC	20
DB2016AS												
DSA1612SDN		1.6	1.2	0.55	CS	9.6 to 60	± 1.0 ± 0.5	-40 to +85	+1.68 to +3.5	VC	IE TC AE	40, 41 84, 85
DSB1612SDN												
DSA211SDN		2.0	1.6	0.8	CS	9.6 to 52	± 1.0 ± 0.5	-40 to +85	+1.68 to +3.5	VC	IE TC AE	40, 41 84, 85
DSB211SDN												
DSA221SDN		2.5	2.0	0.9	CS	9.6 to 52	± 1.0 ± 0.5	-40 to +85	+1.68 to +3.5	VC	IE TC AE	40, 41 84, 85
DSB221SDN												
DSA321SDN		3.2	2.5	1.0	CS	9.6 to 52	± 1.0 ± 0.5	-40 to +85	+1.68 to +3.5	VC	IE TC AE	40, 41 84, 85
DSB321SDN												
DSB1612SEB		1.6	1.2	0.55	CS	2.6 to 76.8	± 5.0	-40 to +105	+1.8 to +3.3	Stb	IE TC AE	39-83
DSB211SJA		2.0	1.6	0.8	CMOS	13 to 54	± 5.0	-40 to +105	+1.7 to +3.6	Stb	IE TC AE	43-86
DSB221SJA		2.5	2.0	0.9	CMOS	11 to 52	± 5.0	-40 to +105	+1.7 to +3.6	Stb	IE TC	43
DSA211SP		2.0	1.6	0.7	CS	12.288 to 52	± 1.0 ± 0.5	-40 to +105	+1.68 to +3.5	VC	AE	82
DSB211SP												
DSA535SGA		5.0	3.2	1.5	CS or CMOS	10 to 52	± 0.1	-40 to +85	+2.3 to +3.63	VC Stb	IE TC	42
DSB535SGA										Stb		
DSA535SGB										VC Stb		

Clock Oscillators (SPXO)

Type	Actual Size	Size (mm)			Output	Frequency Range (MHz)	Frequency Tolerance ($\times 10^{-6}$) (Includes frequency tolerance at room temperature.)	Operating Temperature Range (°C)	Supply Voltage (V)	Current Consumption (mA)	Recommended Application	Catalog Page
		L	W	H (max.)								
DS1008JN		1.05	0.85	0.24	CMOS	1.0 to 100	± 50	-40 to +125	+0.8 to +1.6	1.8 to 3.1	CE TC	15
DS1008JS		1.05	0.85	0.24	CMOS	1.0 to 100	± 50	-40 to +125	+1.6 to +3.3	2.1 to 4.9	CE TC	16
DS2016AS		2.0	1.6	0.8	CMOS	1.0 to 125	± 50	-40 to +125°C	+1.6 to +3.6	1.7 to 10.0	CE TC	17
DS2520AS												
DSO1612AR		1.6	1.2	0.58	CMOS	0.584375 to 80	± 50 ± 100	-40 to +85 -40 to +125	+1.6 to +3.6	1.7 to 3.7	CE TC AE	50 75
DSO221SR		2.5	2.0	0.895	CMOS	0.2 to 167	± 50 ± 100	-40 to +85 -40 to +125	+1.6 to +3.6	1.0 to 8.0 2.5 to 8.0	CE TC AE	52, 53 76
DSO321SR												
DSO531SR		5.0	3.2	1.2	CMOS	0.2 to 167	± 50 ± 100	-40 to +85 -40 to +125	+1.6 to +3.6	1.0 to 8.0 2.5 to 8.0	CE TC	52, 53
DSO751SR		7.3	4.9	1.7								
DSO321SRS		3.2	2.5	1.2	CMOS	8.25 to 66 3.25 to 52	± 100	-40 to +100	+3.0 to +3.6	3.7 8.0	CE IE	54
DSO221SBM												
DSO321SBM		3.2	2.5	1.2	CMOS	0.7 to 90	± 50	-40 to +85	+5.0	4.0 to 8.0 4.0 to 8.0	CE IE	55
DSO531SBM												
DSO751SBM												
DSO211SX		2.0	1.6	0.8	CMOS	1.0 to 125	± 50	-40 to +125	+1.6 to +3.6	1.7 to 10.0	AE	77
DSO221SX		2.5	2.0	0.895								
DSO211SXF		2.0	1.6	0.8	CMOS	1.0 to 125	± 50	-40 to +125	+1.6 to +3.6	1.7 to 10.0	CE TC	51
DSO221SXF												
DSO221SY		2.5	2.0	0.895	CMOS	1.049 to 8.5	± 35 ± 50	-40 to +85	+1.6 to +3.6	0.7	CE TC AE	57 79
DSO321SY												
DLO555MBA		5.0	4.0	5.0	CMOS	1.5 to 54	$\pm 50, \pm 100$	-10 to +85	+1.6 to +5.5	8.0	IE	62

Low Phase Noise Crystal Oscillators (SPXO)

Type	Actual Size	Size (mm)			Output	Frequency Range (MHz)	Frequency Tolerance ($\times 10^{-6}$) (Includes frequency tolerance at room temperature.)	Operating Temperature Range (°C)	Supply Voltage (V)	Current Consumption (mA)	Recommended Application	Catalog Page
		L	W	H (max.)								
DSO221SH		2.5	2.0	0.895	CMOS	3.5 to 52	± 50	-40 to +85	+1.6 to +3.6	2.3 to 4.2	CE TC	47
DSO321SH												
DSO221SHH		2.5	2.0	0.9	CMOS	2.0 to 54	± 50 ± 100	-40 to +85 -40 to +125	+1.62 to +3.6	2.3 to 4.2	CE TC AE	★48 ★74
DSO321SHH												
DSO321SHH		3.2	2.5	1.2	CMOS	20 to 50	± 50	-40 to +85	+1.62 to +3.6	2.9 to 7.7	CE TC	★49

Differential Output Crystal Oscillators (SPXO)

Type	Actual Size	Size (mm)			Output	Frequency Range (MHz)	Frequency Tolerance ($\times 10^{-9}$) (Includes frequency tolerance at room temperature.)	Operating Temperature Range (°C)	Supply Voltage (V)	Current Consumption (mA)	Recommended Application	Catalog Page
		L	W	H (max.)								
DS1008JC	□	1.05	0.85	0.26	HD-LVDS	156.25	± 100	-40 to +85	+3.3	35	IE	18
DS1008JK					LV-PECL					57		
DS1008JJ					LVDS					26		
DS2016AD	□	2.0	1.6	0.8	HCSL	100, 125, 156.25	± 50	-40 to +125°C	+1.8, +2.5, +3.3	40	CE IE TC	19
DS2016AJ					LVDS					20		
DS2016AK					LV-PECL					60		
DS2520AD	□	2.5	2	0.95	HCSL	100, 125, 156.25	± 50	-40 to +125°C	+1.8, +2.5, +3.3	40	CE IE TC	19
DS2520AJ					LVDS					20		
DS2520AK					LV-PECL					60		
DS3225AD	□	3.2	2.5	1.2	HCSL	100, 125, 156.25	± 50	-40 to +125°C	+1.8, +2.5, +3.3	40	CE IE TC	19
DS3225AJ					LVDS					20		
DS3225AK					LV-PECL					60		
DSO223SD	□	2.5	2.0	0.95	HCSL	13.5 to 167	± 50	-40 to +85	+2.5, +3.3	30	CE IE TC	58
DSO223SJ					LVDS					20		
DSO223SK					LV-PECL					45		
DSO323SD	□	3.2	2.5	1.2	HCSL	13.5 to 212.5	± 80	-40 to +105	+1.8, +2.5, +3.3	35	CE IE TC	58, 59
DSO323SJ					LVDS					30		
DSO323SK					LV-PECL					20		
DSO533SJ	□	5.0	3.2	1.2	LVDS	13.5 to 212.5	± 50	-40 to +85	+2.5, +3.3	50	CE IE TC	60
DSO533SK					LV-PECL					35		
DSO753SD					HCSL					20		
DSO753SJ	□	7.3	4.9	1.7	LVDS	13.5 to 212.5	± 50	-40 to +85	+2.5, +3.3	20	CE IE	61
DSO753SK					LV-PECL					50		

Voltage Controlled Crystal Oscillators (VCXO)

Type	Actual Size	Size (mm)			Output	Frequency Range (MHz)	Frequency Tolerance ($\times 10^{-9}$) (Includes frequency tolerance at room temperature.)	Operating Temperature Range (°C)	Frequency Adjustment Range ($\times 10^{-5}$)	Supply Voltage (V)	Current Consumption (mA)	Recommended Application	Catalog Page
		L	W	H (max.)									
DSV221SV	□	2.5	2.0	0.9	CMOS	30.72	± 40	-30 to +85	± 100	+3.3	7.0	CE	63
DSV321SV	□	3.2	2.5	1.2		6.75 to 125					7.0 to 27		

Real Time Clock Module (RTC)/kHz Band TCXO

Type	Actual Size	Size (mm)			Output	Frequency Range (MHz)	Frequency Tolerance ($\times 10^{-9}$)	Operating Temperature Range (°C)	Supply Voltage (V)	Current Consumption (μA)	Temperature Compensated Type	Recommended Application	Catalog Page
		L	W	H (max.)									
DD3225TS	□	3.2	2.5	1.0	CMOS	32.768	± 7.0	-40 to +105	+1.3 to +5.5	2.9, 4.0	Digital	CE IE AE	45, 89
DD3225TR	□	3.2	2.5	1.0	CMOS	32.768	± 11.5	-40 to +85	+1.3 to +5.5	2.9, 4.0	Analog	CE IE	46
DSK1612ATD	□	1.6	1.2	0.65	CMOS	32.768	± 5.0	-40 to +85	+1.5 to +3.63	3.2 to 3.5	Digital	CE IE AE	44, 87
DSK321STD	□	3.2	2.5	1.0	CMOS	32.768	± 5.0	-40 to +85	+1.5 to +3.63	3.2, 3.5	Digital	AE	88

kHz Band SPXO

Type	Actual Size	Size (mm)			Output	Frequency Range (MHz)	Frequency Tolerance ($\times 10^{-9}$) (Includes frequency tolerance at room temperature.)	Operating Temperature Range (°C)	Supply Voltage (V)	Current Consumption (μA)	Recommended Application	Catalog Page
		L	W	H (max.)								
DSO1612AR (kHz)	□	1.6	1.2	0.6	CMOS	32.768	± 100	-40 to +125	+1.6 to +3.6	32	CE TC	56
DSO221SR (kHz)	□	2.5	2.0	0.895		32.768 to 50	± 100	-40 to +125	+1.6 to +5.5	65 to 120	AE	78
DSO321SR (kHz)	□	3.2	2.5	1.2	CMOS	32.768	± 35 ± 50	-40 to +85	+1.6 to +3.6	18	CE TC	57
DSO221SY (kHz)	□	2.5	2.0	0.895							AE	79
DSO321SY (kHz)	□	3.2	2.5	1.2								

Selection Guide



Scan the QR code to check the table of contents page of our web site "Monolithic Crystal Filters" (URL: <https://www.kds.info/class/3-l-cf/>).

Icons IE Industrial Equipment TC Mobile Phone, Wireless Communication

Monolithic Crystal Filters

Type	Actual Size	Size (mm)			Frequency Range (MHz)	Operating Temperature Range (°C)	Overtone Order	Pole	Pass Bandwidth (kHz min./3dB)	Recommended Application	Catalog Page
		L	W	H (max.)							
DSF334SAF		3.0	3.0	1.1	45 to 130	-20 to +70	Fundamental	2	±3.5, ±7.5, ±15	TC	93
DSF334SAO					100 to 160		3rd				
DSF334SCF					60 to 130		Fundamental	3			
DSF444SAF		3.8	3.8	1.1	40 to 130		Fundamental	2			
DSF444SAO					100 to 160		3rd				
DSF444SCF					60 to 130		Fundamental	3			
DSF633SAF		6.0	3.5	1.3	20 to 160	-20 to +70	Fundamental	4	±3.5, ±7.5, ±15	IE TC	94
DSF633SDF					37 to 130		Fundamental				
DSF633SDO					60 to 160		3rd				
DSF753SAF		7.0	5.0	1.5	16 to 90	-20 to +70	Fundamental	2	±3.5, ±7.5, ±15	IE TC	95
DSF753SAO					60 to 160		3rd				
DSF753SCF					20 to 130		Fundamental	3			
DSF753SCO					90 to 160		3rd				
DSF753SBF					30 to 70		Fundamental	4			
DSF753SDF					20 to 130						
DSF753SDO					60 to 160						

Selection Guide



Scan the QR code to check the table of contents page of our web site "MEMS Oscillators" (URL: <https://www.kds.info/class/4-l-mems/>).

Icons **CE** Consumer Equipment **IE** Industrial Equipment **TC** Mobile Phone, Wireless Communication

KHz Band MEMS Oscillator

Type	Actual Size	Size (mm)			Output	Frequency Range (kHz)	Frequency Characteristics over Temperature ($\times 10^{-5}$)	Operating Temperature Range (°C)	Supply Voltage (V)	Current Consumption (μ A typ.)	Recommended Application	Catalog Page
		L	W	H (max.)								
MO1532		1.5	0.8	0.6	NanoDrive™ LVC MOS	32.768	± 100	-40 to +85	+1.2 to +3.63	+0.90	CE TC	98
MO1534		1.5	0.8	0.6	NanoDrive™ LVC MOS	0.001 to 32.768	± 100	-40 to +85	+1.2 to +3.63	+0.90	CE TC	99
		2.0	1.2	0.6								
MO1569		1.5	0.8	0.6	LVC MOS	0.001 to 462	± 50	-40 to +85	+1.62 to +3.63	+2.0 μ A (100kHz)	CE TC	98
MO1630		2.0	1.2	0.6	LVC MOS	16.384, 32.768	± 150	-40 to +105	+1.5 to +3.63	+1.00	CE TC	98

KHz Band Temperature Compensated MEMS Oscillators

Type	Actual Size	Size (mm)			Output	Frequency Range (kHz)	Frequency Characteristics over Temperature ($\times 10^{-5}$)	Operating Temperature Range (°C)	Supply Voltage (V)	Current Consumption (μ A typ.)	Recommended Application	Catalog Page
		L	W	H (max.)								
MO1552		1.5	0.8	0.6	NanoDrive™ LVC MOS	32.768	$\pm 5/\pm 10/\pm 20$ over temp.	-40 to +85	+1.5 to +3.63	+0.99	CE TC	98
MO1566					LVC MOS				± 3 all inclusive	+1.8		
MO1568					LVC MOS	± 5 all inclusive After Overmold/Underfill	-40 to +85	+1.62 to +3.63	+8.0 μ A (100kHz)	CE TC	99	
MO1576					LVC MOS	± 5 all inclusive						

Low Power MEMS Oscillators

Type	Actual Size	Size (mm)			Output	Frequency Range (MHz)	Frequency Tolerance ($\times 10^{-5}$) (Includes frequency tolerance at room temperature.)	Operating Temperature Range (°C)	Supply Voltage (V)	Current Consumption (mA typ.)	Recommended Application	Catalog Page
		L	W	H (max.)								
MO8021		1.5	0.8	0.6	LVC MOS	1.0 to 26	± 100	-40 to +85	+1.62 to +1.98, +2.25 to +3.63	+0.006 to +0.34 (+0.9 μ A stby)	CE TC	99

Low Phase Jitter MEMS Oscillators

Type	Actual Size	Size (mm)			Output	Frequency Range (MHz)	Frequency Tolerance ($\times 10^{-5}$) (Includes frequency tolerance at room temperature.)	Operating Temperature Range (°C)	Supply Voltage (V)	Current Consumption (mA typ.)	Recommended Application	Catalog Page					
		L	W	H (max.)													
MO8208		2.7	2.4	0.8	LVC MOS	1.0 to 80	$\pm 10, \pm 20, \pm 25, \pm 50$	-40 to +85	+2.25 to +3.63	+29 to +36 (+10 μ A stby)	CE IE	101					
MO8209														5.0	3.2	0.8	80 to 220
MO9120		3.2	2.5	0.8	LVPECL LVDS	25 to 212.5	$\pm 10, \pm 20, \pm 25, \pm 50$	-40 to +85	+2.25 to +3.63	+54 to +69	CE IE	100					
MO9121														5.0	3.2	0.8	1.0 to 220
MO9122														7.0	5.0	1.0	220 to 625
MO9365		3.2	2.5	0.8	LVPECL LVDS HCSL	32 Standard Frequencies	$\pm 10, \pm 20, \pm 25, \pm 50$	-40 to +105	+2.25 to +3.63	+76 to +84	CE IE	100					
MO9366														5.0	3.2	0.8	1.0 to 220
MO9367														7.0	5.0	1.0	220 to 725

Temperature Compensated MEMS Oscillators

Type	Actual Size	Size (mm)			Output	Frequency Range (MHz)	Frequency Characteristics over Temperature ($\times 10^{-5}$)	Operating Temperature Range (°C)	Supply Voltage (V)	Current Consumption (mA typ.)	Recommended Application	Catalog Page
		L	W	H (max.)								
MO5155		5.0	3.2	1.0	Clipped Sinewave (1 to 60 MHz) LVC MOS	10 std. GNSS Freq.	-40 to +105°C	+2.25 to +3.63	+40 to +50	CE IE	102	
MO5156						1.0 to 60						$\pm 0.5, \pm 1.0, \pm 2.5$
MO5157						60 to 220						
MO5356					Clipped Sinewave, LVC MOS	1.0 to 60	$\pm 0.1, \pm 0.2, \pm 0.25$					
MO5357						60 to 220						
MO5358						1.0 to 60		0 to +70°C				
MO5359						60 to 189, 200 to 220						

MEMS Oscillators with Spread Spectrum Function

Type	Actual Size	Size (mm)			Output	Frequency Range (MHz)	Frequency Tolerance ($\times 10^{-5}$) (Includes frequency tolerance at room temperature.)	Operating Temperature Range (°C)	Supply Voltage (V)	Current Consumption (mA typ.)	Recommended Application	Catalog Page
		L	W	H (max.)								
MO9005		2.0	1.6	0.8	LVC MOS	1.0 to 141	$\pm 20, \pm 25, \pm 50$	-40 to +85	+1.62 to +1.98, +2.25 to +3.63	+5.0 to +6.5 (+0.4 to +4.3 μ A stby)	CE IE	97
		2.5	2.0	0.8								
		3.2	2.5	0.8								

Quartz Devices

Arkh.Series

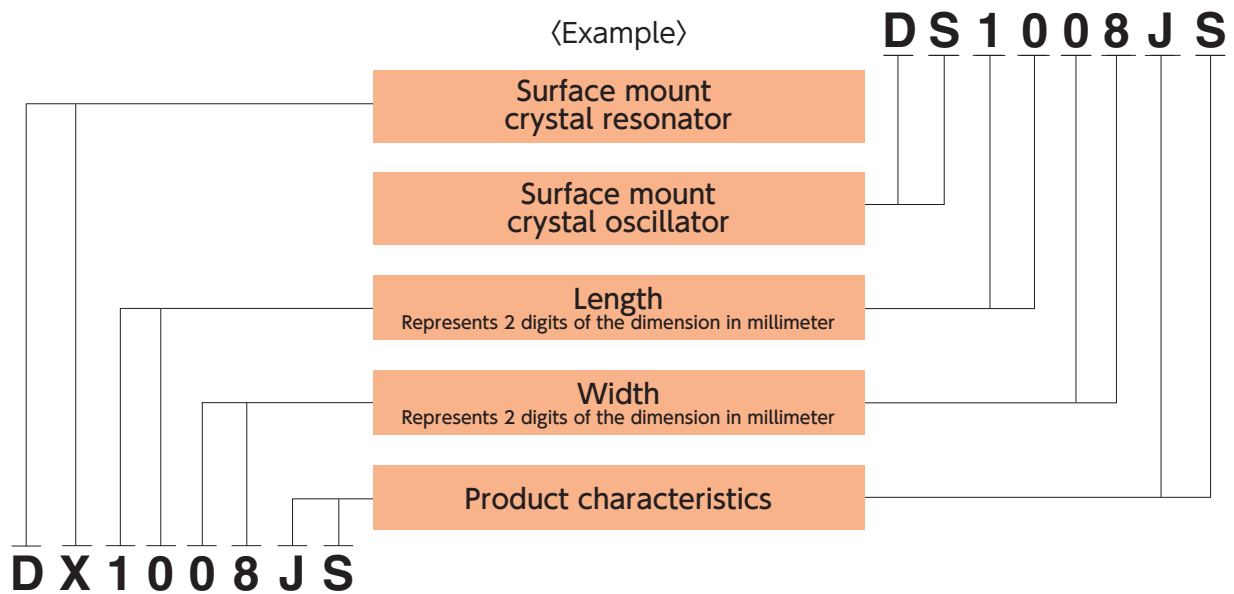
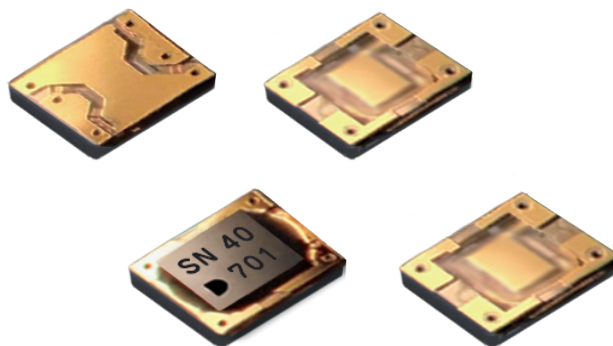

Ark.3G SERIES

About Arkh.Series



Ark. Series

The Arkh Series is a device with an unprecedented new structure developed as the third generation following the lead type and the surface-mount type.

The brand name "Arkh" is taken from the ancient Greek word "Arkhitekton", which is the origin of the English word "Architecture". It is not just a structure, but contains the desire to emphasize that it is the origin of crystal devices with a completely new structure.

About the Structure of the Arkh Series

<Ark.3G>

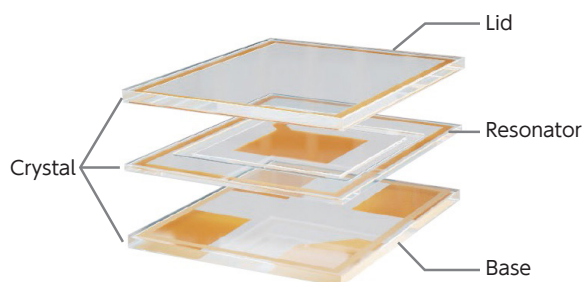

The Arkh.3G is an ultra-compact and thin device realized by WLP (Wafer Level Package) technology and is arranged in a three-layer structure consisting of a lid, resonator, and base, the host of which is quartz crystal. With the outlines of the resonator and other parts having been formed by a photolithographic process, three quartz crystal wafers are bonded and diced into a waferlevel package. Thus the holder and resonator parts are formed into an integrated structure without the use of a conductive adhesive.

This design has solved the challenges that the conventional structure needed to meet for product size reduction, namely, improved accuracy in conductive adhesive application and the provision of a margin for ensuring a quartz crystal element mounting location. Additionally, it is possible to reduce quality risks by carrying out processes ranging from wafer cleaning to bonding in a vacuum environment.

WLP technology

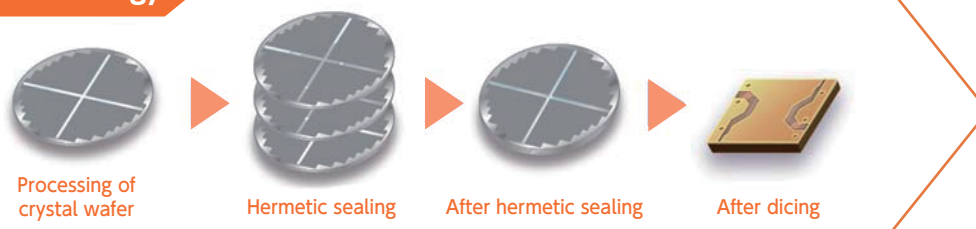

About Mounting and Usage of the Arkh.Series

The Arkh.Series can be soldered to circuit boards with a pick-and-place machine in the conventional manner. The Arkh.3G can also be built into an IC package or used for wire bonding or molding.

*Note that, as with conventional products, the Arkh.3G is subject to resonance fracture or damage, depending on conditions such as ultrasonic cleaning and molding pressure. Therefore, it is necessary to check the Arkh.3G in advance under your particular operating conditions.

SMD Crystal Resonators / MHz Band Crystal Resonators

DX1008JS

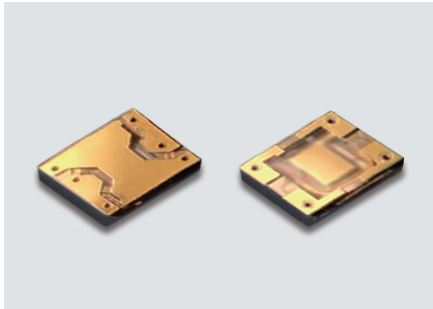

Actual size □

■ Features

- 1008 size, height 0.12mm
Unprecedented extremely low-profile package using a novel structure
- Composed only of quartz crystal plates and metallic films without the use of a ceramic base
- Long-term high resistance to aging, due to avoiding the use of an organic conductive adhesive
- Reduced risk of the inclusion of foreign matter due to assembly in a vacuum environment



■ Applications

- Mobile communications and short-range wireless modules
- Wearable devices
- Multimedia devices

■ Standard Specification

Item \ Type	DX1008JS		
Frequency Range	48 to 52MHz	52 to 96MHz	96 to 120MHz
Overtone Order	Fundamental		
Load Capacitance	8pF, 10pF, 12pF		
Drive Level	10μW (100μW max.)		
Frequency Tolerance	±20×10 ⁻⁶ (at 25°C)		±100×10 ⁻⁶ (at 25°C)
Series Resistance	100Ω max.	60Ω max.	40Ω max.
Frequency Characteristics over Temperature	±30×10 ⁻⁶ / -30 to +85°C (Ref.To 25°C)		
Storage Temperature Range	-40 to +85°C		
Packing Unit (1)	3000pcs./reel (φ180)		

(1) Moisture prevention packing is unnecessary.
Moisture Sensitivity Level: LEVEL1 (IPC/JEDEC J-STD-033)

Consult our sales representative for other specifications

[mm]

■ Dimensions

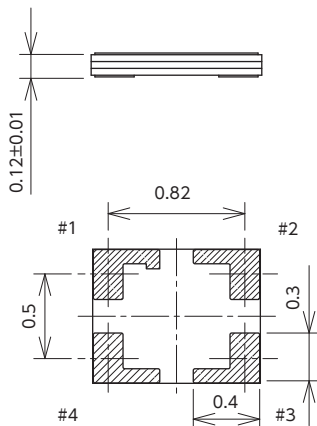
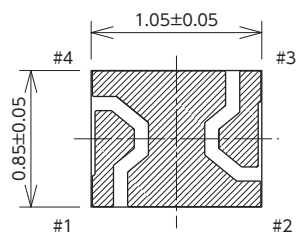

■ Internal Connections

〈Top View〉

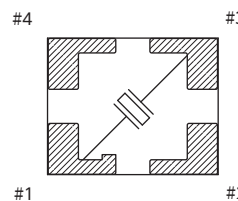

■ Recommended Land Pattern

〈Top View〉

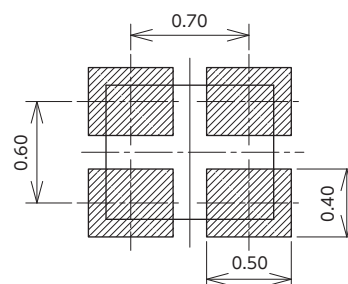

SMD Crystal Resonators / MHz Band Crystal Resonators

DX1008JT

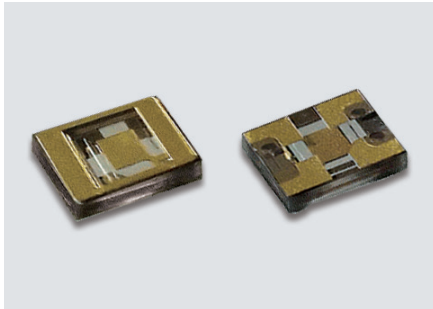

Features

- 1008 size, height 0.18mm
Unprecedented extremely low-profile package using a novel structure
- Composed only of quartz crystal plates and metallic films without the use of a ceramic base
- Long-term high resistance to aging, due to avoiding the use of an organic conductive adhesive

Applications

- Mobile communications and short-range wireless modules
- Wearable devices
- Multimedia devices



Standard Specification

Item	Type	DX1008JT	
Frequency Range		59.97MHz	76.8MHz
Overtone Order		Fundamental	
Load Capacitance		5pF, 8pF, 10pF, 12pF	
Drive Level		10μW (100μW max.)	
Frequency Tolerance		±10×10 ⁻⁶ , ±20×10 ⁻⁶	
Series Resistance		60Ω max.	50Ω max.
Frequency Characteristics over Temperature		±12×10 ⁻⁶ , ±30×10 ⁻⁶ / -30 to +85°C (Ref.To 25°C)	
Storage Temperature Range		-40 to +85°C	
Packing Unit (1)		3000pcs./reel (φ180)	

(1) Moisture prevention packing is unnecessary.
Moisture Sensitivity Level: LEVEL1 (IPC/JEDEC J-STD-033)

Consult our sales representative for other specifications

[mm]

Dimensions

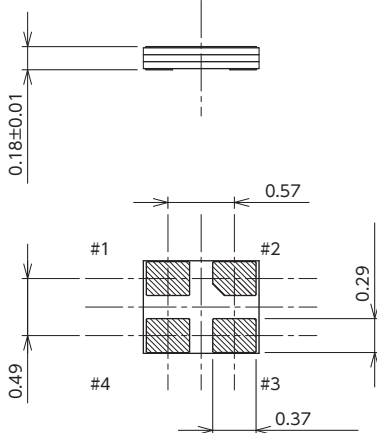
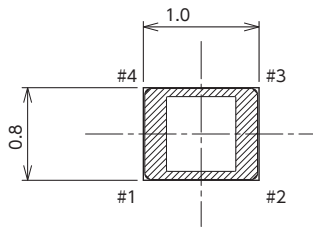

Internal Connections

<Top View>

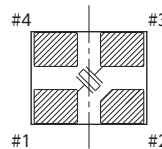

Pin Connection

Pin No.	Connection
#1	Xtal
#2	GND
#3	Xtal
#4	GND

Recommended Land Pattern

<Top View>

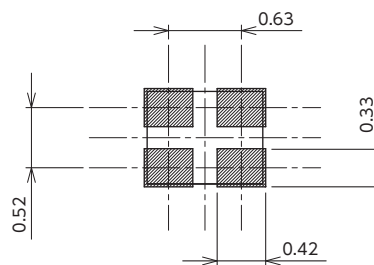

SMD Crystal Oscillators

DS1008JN

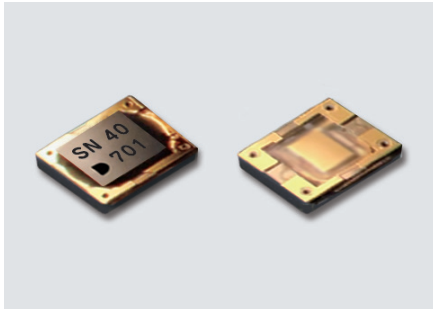

Actual size □

■ Features

- 1008 size, height 0.22mm
- Unprecedented extremely low-profile package using a novel structure
- Available frequency range : 1 to 100MHz
- Low Supply Voltage : 0.9V/ 1.2V/ 1.3V/ 1.5V typ.
- 3-state function
- CMOS level output
- Available up to 100MHz by using AT cut fundamental resonator.
- Low jitter provides for high performance.

■ Applications

- Medical camera
- Wearable devices
- IoT devices
- Multimedia device



[Function Code]
DS1008JN E A

E : 1.5V	←	A : ±100×10 ⁻⁶
F : 1.3V	←	B : ±50×10 ⁻⁶
G : 1.2V	←	C : ±30×10 ⁻⁶
H : 0.9V	←	E : ±20×10 ⁻⁶

When requesting the product, please select the model and function code of your request.

■ Standard Specification

Item	Type	Function Code		Output Frequency Range (MHz)	Legend	Spec.			Condition		
		Supply Voltage	Frequency Tolerance			min.	typ.	max.	Unit		
Supply Voltage		E	*	1 ≤ f ₀ ≤ 100	Vcc	1.4	1.5	1.6	V		
		F				1.2	1.3	1.4			
		G				1.1	1.2	1.3			
		H				0.8	0.9	1.0			
Frequency Tolerance (Includes frequency tolerance at room temperature.)	*	A	*	*	f _{tol}	—	—	±100	ppm	-40 to +125°C	-20 to +70°C (Standard Operating Temperature Range)
		B				—	—	±50			
		C				—	—	±30			
		E				—	—	±20			
Current Consumption	E	*	*	80 ≤ f ₀ ≤ 100	lcc	—	—	3.1	mA	No Load	
				50 ≤ f ₀ < 80		—	—	2.7			
				1 ≤ f ₀ < 50		—	—	2.2			
	F	*	*	80 ≤ f ₀ ≤ 100		—	—	2.8			
				50 ≤ f ₀ < 80		—	—	2.5			
				1 ≤ f ₀ < 50		—	—	2.1			
	G	*	*	80 ≤ f ₀ ≤ 100		—	—	2.7			
				50 ≤ f ₀ < 80		—	—	2.4			
				1 ≤ f ₀ < 50		—	—	2.0			
	H	*	*	80 ≤ f ₀ ≤ 100		—	—	2.3			
				50 ≤ f ₀ < 80		—	—	2.1			
				1 ≤ f ₀ < 50		—	—	1.8			
Stand-by Current (#1 pin "L" Level)	*	*	*	L _{std}	—	—	0.02	mA			
Load Condition	*	*	*	L _{CMOS}	—	—	15	pF			
Symmetry	*	*	*	SYM	40	50	60	%	at 50%		
Rise and Fall Time	*	*	*	tr, tf	—	—	5	ns	10 to 90% Vcc Level		
Output Enable Time	*	*	*	tPZL	—	—	2	ms			
Output Disable Time	*	*	*	tPLZ	—	—	200	ns			
OE Pin 1 Level Input Voltage	*	*	*	V _{IH}	Vcc×0.8	—	—	V			
OE Pin 0 Level Input Voltage	*	*	*	V _{IL}	—	—	Vcc×0.2	V			
Packing Unit (1)	3000pcs./reel(φ180)										

(1) Moisture prevention packing

Consult our sales representative for other specifications

[mm]

■ Dimensions

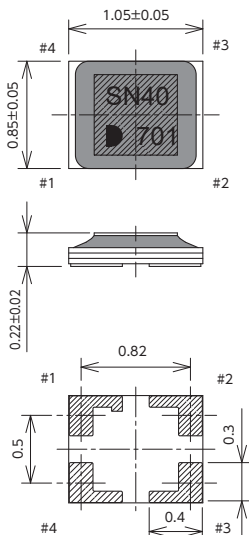

Pin Connection

Pin No.	Connection
#1	OE (Output Enable)
#2	GND
#3	Output
#4	Vcc

Function

#1 Input	#3 Output condition
H	Oscillation out
Open	Oscillation out
L	High Z

■ Recommended Land Pattern

<Top View>

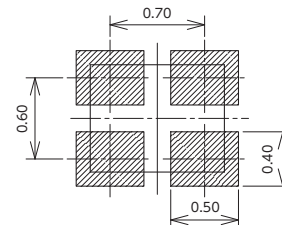

SMD Crystal Oscillators

DS1008JS

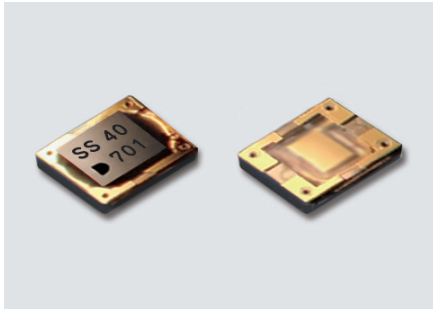

Actual size □

■ Features

- 1008 size, height 0.22mm
Unprecedented extremely low-profile package using a novel structure
- Available frequency range : 1 to 100MHz
- Supply Voltage : +1.8V to +3.3V
- 3-state function
- CMOS level output
- Available up to 100MHz by using AT cut fundamental resonator.
Low jitter provides for high performance.



■ Applications

- Mobile communications and short-range wireless modules
- Wearable devices
- Multimedia device

[Function Code]

DS1008JS A A

A : 3.3V — A : $\pm 100 \times 10^{-6}$
 B : 2.8V — B : $\pm 50 \times 10^{-6}$
 C : 2.5V — C : $\pm 30 \times 10^{-6}$
 D : 1.8V — E : $\pm 20 \times 10^{-6}$

When requesting the product, please select the model and function code of your request.

■ Standard Specification

Item	Type	Function Code		Output Frequency Range (MHz)	Legend	Spec			Unit	Condition					
		Frequency Tolerance	Frequency Tolerance			min.	typ.	max.							
Supply Voltage	A	*	*	$1 \leq f_0 \leq 100$	Vcc	3.0	3.3	3.6	V						
	B					2.6	2.8	3.0							
	C					2.25	2.5	2.75							
	D					1.6	1.8	2.0							
Frequency Tolerance (Includes frequency tolerance at room temperature.)	*	*	A	*	f_tol	—	—	± 100	ppm	-40 to +125°C	-20 to +70°C (Standard Operating Temperature Range)				
	B					—	—	± 50							
	C					—	—	± 30							
	E					—	—	± 20							
Current Consumption	A	*	*	$80 \leq f_0 \leq 100$	lcc	—	—	4.9	mA	No Load					
				$48 \leq f_0 < 80$		—	—	4.2							
				$1 \leq f_0 < 48$		—	—	3.1							
	B	*	80 $\leq f_0 \leq 100$	—		—	4.2								
				$48 \leq f_0 < 80$		—	—	3.7							
				$1 \leq f_0 < 48$		—	—	2.7							
	C	*	80 $\leq f_0 \leq 100$	—		—	3.9								
				$48 \leq f_0 < 80$		—	—	3.4							
				$1 \leq f_0 < 48$		—	—	2.6							
	D	*	80 $\leq f_0 \leq 100$	—		—	3.1								
				$48 \leq f_0 < 80$		—	—	2.8							
				$1 \leq f_0 < 48$		—	—	2.1							
	Stand-by Current (#1 pin "L" Level)	*	*	*		l_std	—	—				0.01	mA		
	Load Condition	*	*	*		L_cmos	—	—				15	pF		
	Symmetry	*	*	*		SYM	45	50				55	%	at 50% Vcc f ₀ < 60MHz	
	Rise and Fall Time	*	*	*		tr, tf	—	—				5	ns	10 to 90% Vcc Level	
Output Enable Time	*	*	*	tPZL	—	—	2	ms							
Output Disable Time	*	*	*	tPLZ	—	—	200	ns							
OE Pin 1 Level Input Voltage	*	*	*	V _{IH}	Vcc × 0.8	—	—	V							
OE Pin 0 Level Input Voltage	*	*	*	V _{IL}	—	—	Vcc × 0.2	V							
Packing Unit (1)	3000pcs./reel(φ180)														

(1) Moisture prevention packing

Consult our sales representative for other specifications

[mm]

■ Dimensions

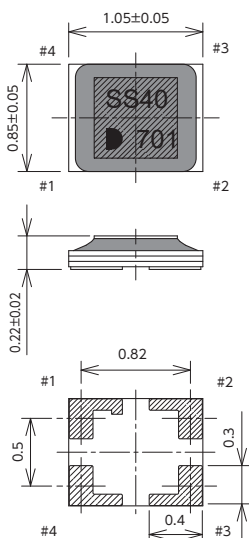

Pin Connection

Pin No.	Connection
#1	OE (Output Enable)
#2	GND
#3	Output
#4	Vcc

Function

#1 Input	#3 Output condition
H	Oscillation out
Open	Oscillation out
L	High Z

■ Recommended Land Pattern

<Top View>

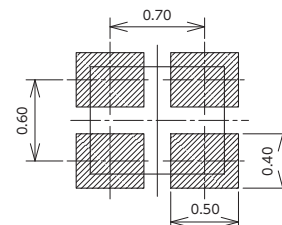

SMD Crystal Oscillators

Under Development

DS2016AS/DS2520AS

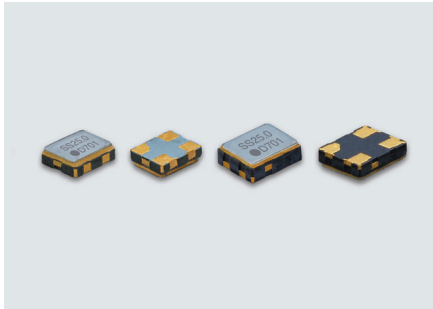

Actual size DS2016AS DS2520AS

Features

- Supply Voltage : 1.8V/2.5V/2.8V/3.3V
- Available Frequency range: 1 to 125MHz
- Low Profile : 0.7mm(DS2016AS), 0.8mm(DS2520AS)
- CMOS Level Output
- Supports a wide operating temperature range from -40 to 125°C
- AEC-Q100/AEC-Q200 compliant

Applications

- Audio equipment, communication equipment, video equipment, factory automation equipment, PCs, amusement equipment, In-vehicle driving safety applications



[Function Code]

DS****AS A A

- | | |
|----------|---------------------------|
| A : 3.3V | A : ±100×10 ⁻⁶ |
| B : 2.8V | Z : ±80×10 ⁻⁶ |
| C : 2.5V | B : ±50×10 ⁻⁶ |
| D : 1.5V | C : ±30×10 ⁻⁶ |
| | D : ±25×10 ⁻⁶ |
| | E : ±20×10 ⁻⁶ |

When requesting the product, please select the model and function code of your request.

Standard Specification

Item	Function Code		Output Frequency Range (MHz)	Legend	Spec.			Unit	Condition	
	Supply Voltage	Frequency tolerance			min	typ.	max.			
Supply Voltage	A	*	1 ≤ f _o ≤ 125	V _{cc}	+3.0	+3.3	+3.6	V		
	B				+2.6	+2.8	+3.0			
	C				+2.25	+2.5	+2.75			
	D				+1.6	+1.8	+2.0			
Frequency Tolerance (Includes frequency tolerance at room temperature)	*	A	*	f _{tol}	-100	-	+100	× 10 ⁻⁶	-40 to +125 °C	-10 to +70°C (Standard Operating Temperature Range)
		Z			-80	-	+80			
		B			-50	-	+50			
		C			-50	-	+50			
		D			-30	-	+30			
Current Consumption	A, B, C, D	*	1 ≤ f _o < 40 40 ≤ f _o < 100 100 ≤ f _o ≤ 125	I _{cc}	-	-	2.4	mA	No Load	
					-	-	4.2			
					-	-	10.0			
					-	-	2.2			
					-	-	3.7			
					-	-	9.0			
					-	-	2.0			
					-	-	3.4			
					-	-	8.0			
					-	-	1.7			
					-	-	2.7			
					Stand-by Current (#1 pin"L Level)	*	*			
Load Condition	*	*	*	L _{CMOS}	-	-	15	pF		
Symmetry	*	*	*	SYM	45	50	55	%	at 50% V _{cc}	
0 Level Output Voltage	*	*	*	V _{OL}	-	-	V _{cc} × 0.1	V		
1 Level Output Voltage	*	*	*	V _{OH}	V _{cc} × 0.9	-	-	V		
Rise and Fall Time	A, B, C, D	*	*	tr, tf	-	-	3 5	ns	10 to 90% V _{cc} Level	
OE Pin 0 Level Input Voltage	*	*	*	V _{IL}	-	-	V _{cc} × 0.3	V		
OE Pin 1 Level Input Voltage	*	*	*	V _{IH}	V _{cc} × 0.7	-	-	V		
Output Disable Time	*	*	*	t _{PLZ}	-	-	200	ns		
Output Enable Time	*	*	*	t _{PZL}	-	-	2	ms		
Phase Jitter	*	*	40 ≤ f _o ≤ 125 10 ≤ f _o < 40	tpj	-	-	1	ps	f _o offset: 12kHz to 20MHz f _o offset: 12kHz to 5MHz	
Packing unit(1)					3000pcs./reel(Φ 180)					

(1) Moisture prevention packing is unnecessary.

Moisture Sensitivity Level: Level1 (IPC/JEDEC J-STD-033)

Consult our sales representative for other specifications

DS2016AS

[mm]

DS2520AS

[mm]

Dimensions

Model Code: SS|25|0|
Frequency: []

Pin Connections

Pin No.	Connection
#1	OE(Output Enable)
#2	GND
#3	Output
#4	V _{cc}

Function

#1 Input	#3 Output condition
H	Oscillation out
L	High Z

Recommended Land Pattern (Top View)

Dimensions

Model Code: SS|25|0|
Frequency: []

Pin Connections

Pin No.	Connection
#1	OE(Output Enable)
#2	GND
#3	Output
#4	V _{cc}

Function

#1 Input	#3 Output condition
H	Oscillation out
L	High Z

Recommended Land Pattern (Top View)

SMD Differential Output Crystal Oscillators

DS1008JC/DS1008JK/DS1008JJ

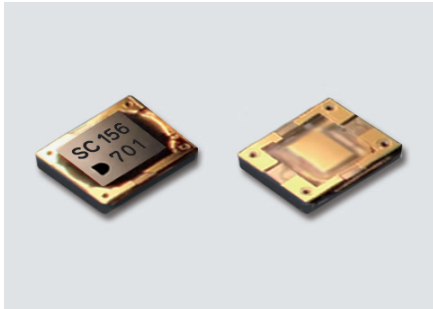

Actual size ◻

■ Features

- 1008 size, height 0.24mm
Unprecedented extremely low-profile package using a novel structure
- Available frequency range : 156.25MHz
- HD-LVDS output (DS1008JC)
- LV-PECL out put (DS1008JK)
- LVDS output (DS1008JJ)
- By using AT cut fundamental resonator, low jitter provides for high performance.



■ Applications

- Optical transmission device

■ Standard Specification

Item	Type	Legend	DS1008JC	DS1008JK	DS1008JJ	Condition
Output Specification	—		HD-LVDS	LV-PECL	LVDS	
Output Frequency Range	f _o		156.25MHz			
Supply Voltage	V _{cc}		+3.3V±0.165V		+2.5V±0.125V / +3.3V±0.165V	
Frequency Tolerance (Includes frequency tolerance at room temperature.)	f _{tol}		±100×10 ⁻⁶ max.			-40 to +85°C
Current Consumption	I _{cc}		35mA max.	57mA max.	26mA max.	
Load Condition	Load-R		100Ω (Output-OutputN, DC Cut)	50Ω to V _{cc} -2.0V	100Ω (Output-OutputN)	
Symmetry	SYM		45 to 55%			at outputs cross point
0 Level Output Voltage	V _{OL}		—	V _{cc} -1.81 to V _{cc} -1.62	—	
1 Level Output Voltage	V _{OH}		—	V _{cc} -1.025 to V _{cc} -0.88	—	
Rise and Fall Time	t _r , t _f		0.4ns max	0.5ns max	0.4ns max	20 to 80% Output-OutputN
Differential Output Voltage	V _{OD1} , V _{OD2}		0.500 to 1.000V	—	0.247 to 0.454V	
Change to V _{OD}	ΔV _{OD}		—	—	50mV	ΔV _{OD} =ABS(V _{OD1} -V _{OD2})
Offset Voltage	V _{OS}		—	—	1.125 to 1.375V	Output, OutputN Offset Voltage
Offset to V _{OS}	ΔV _{OS}		—	—	50mV	Magnitude Change V _{OS}
Start Up Time	T _{st}		2ms			
Period Jitter (1)	t _{RMS}		2.5ps typ.			
	t _{p-p}		22ps typ.			Peak to peak
Phase Jitter (2)	t _{pj}		0.1ps max.		0.12ps max.	f _o offset: 12kHz to 20MHz @ +25°C
Packing Unit (3)			3000pcs./reel (φ180)			

(1) Measured WAVECREST DTS-2075

(2) Measured Keysight Technologies E5052B

(3) Moisture prevention packing

Consult our sales representative for other specifications

[mm]

■ Dimensions

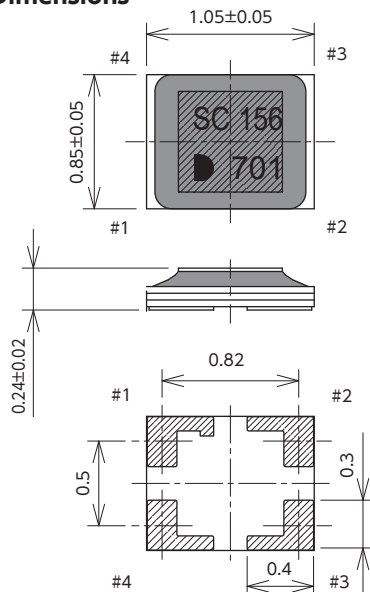

Pin Connection

Pin No.	Connection
#1	GND
#2	OutputN
#3	Output
#4	V _{cc}

■ Recommended Land Pattern

〈Top View〉

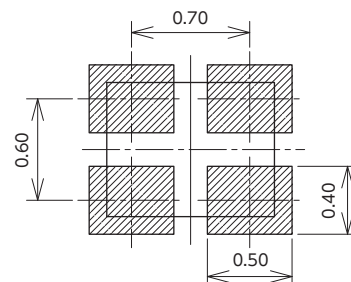

SMD Differential Output Crystal Oscillators

DS2016AK/DS2520AK/DS3225AK/DS2016AJ/DS2520AJ/DS3225AJ/DS2016AD/DS2520AD/DS3225AD

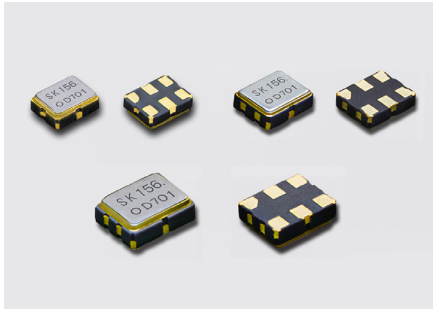

Actual size DS2016A SERIES □ DS2520A SERIES □
DS3225A SERIES □

Features

- Available frequency: 100MHz, 125MHz, 156.25MHz
- Capable of operating over a wide temperature range from -40 to 105°C
- LV-PECL Output (DS2016AK/DS2520AK/DS3225AK), 2.5V/3.3V operating
- LVDS Output (DS2016AJ/DS2520AJ/DS3225AJ), 1.8V/2.5V/3.3V operating
- HCSL Output (DS2016AD/DS2520AD/DS3225AD), 1.8V/2.5V/3.3V operating
- AEC-Q100/AEC-Q200 compliant

Applications

- Optical transceiver, Optical transmission device, Communication base station, Automotive multimedia device



[Function Code]

DS****AK A A

A : 3.3V
C : 2.5V
D : 1.8V

A : ±100×10⁻⁶
B : ±50×10⁻⁶

When requesting the product, please select the model and function code of your request.

Standard Specification

Item	Type	Symbol	DS2016AK DS2520AK DS3225AK	DS2016AJ DS2520AJ DS3225AJ	DS2016AD DS2520AD DS3225AD
Output Specification		—	LV-PECL	LVDS	HCSL
Output Frequency Range		f _o	100MHz/125MHz/156.25MHz		
Supply Voltage		V _{cc}	+2.5±0.125V/+3.3±0.165V	+1.8±0.090V/+2.5±0.125V/+3.3±0.165V	
Frequency Tolerance		f _{tol}	±50×10 ⁻⁶ max., ±100×10 ⁻⁶ max.		
Storage Temperature Range		T _{stg}	-40 to +125°C		
Operating Temperature Range		T _{use}	-40 to +85°C, -40 to +105°C, -40 to +125°C		
Current Consumption		I _{cc}	60mA max.	20mA max.	40mA max.
Stand-by Current (#1 pin "L" Level)		I _{std}	10 μA max.		
Load Condition		Load-R	50Ω to V _{cc} -2V	100Ω Output-OutputN	50Ω
Symmetry		SYM	45 to 55% [1/2V _{OPP}]		
0 Level Output Voltage		V _{OL}	V _{cc} -1.810 to V _{cc} -1.590V	0.90V min.	-0.15 to +0.15V
1 Level Output Voltage		V _{OH}	V _{cc} -1.105 to V _{cc} -0.860V	1.60V max.	+0.55 to +0.90V
Rise and Fall Time		tr, tf	0.4ns max. [20 to 80% V _{OPP}]		0.5ns max.(2.5V,3.3V), 0.6ns max.(1.8V) [20 to 80% V _{OPP}]
Output Voltage		V _{OPP}	0.40V min.	0.25V min.	0.55V min
Differential Output Voltage		V _{OD1} , V _{OD2}	—	0.247 to 0.454V	—
Change to V _{OD}		ΔV _{OD}	—	50mV [ΔV _{OD} = V _{OD1} -V _{OD2}]	—
Offset Voltage		V _{OS}	—	1.125 to 1.375V	—
Offset to V _{OS}		ΔV _{OS}	—	50mV	—
OE pin 0 Level input Voltage		V _{IL}	V _{cc} ×0.3max.		
OE pin 1 Level input Voltage		V _{IH}	V _{cc} ×0.7min.		
Output Disable time		t _{PLZ}	200ns		
Output Enable time		t _{PZL}	2ms		
Phase Jitter [fo offset: 1.2kHz to 20MHz]		t _{pj}	32fs typ., 60fs max. (156.25MHz/V _{cc} =+2.5V, +3.3V)	38fs typ., 60fs max. (156.25MHz/V _{cc} =+2.5V, +3.3V) 45fs typ., 80fs max. (156.25MHz/V _{cc} =+1.8V)	34fs typ., 60fs max. (156.25MHz/V _{cc} =+2.5V, +3.3V) 43fs typ., 80fs max. (156.25MHz/V _{cc} =+1.8V)
Packing Unit(1)			DS2016A SERIES, DS2520A SERIES: 3000pcs./reel (Φ180), DS3225A SERIES: 2000pcs./reel (Φ180)		

(1) Moisture prevention packing is unnecessary.
Moisture Sensitivity Level: Level1 (IPC/JEDEC J-STD-033)

Consult our sales representative for other specifications

DS2016A SERIES [mm]

DS2520A SERIES [mm]

DS3225A SERIES [mm]

DS2016A SERIES [mm]	DS2520A SERIES [mm]	DS3225A SERIES [mm]
<p>Dimensions</p> <p>Model Code: DS2016AKSK, DS2016AKSJ, DS2016ADSD</p> <p>Frequency: 100MHz, 125MHz, 156.25MHz</p> <p>Pin Connections: #1: OE #2: NC #3: GND #4: Output #5: OutputN #6: Vcc</p> <p>Function: #1 Input, #4, #5 Output condition: Open or "H" Oscillation out, High-Z</p> <p>Recommended Land Pattern (Top View)</p>	<p>Dimensions</p> <p>Model Code: DS2520AKSK, DS2520AKSJ, DS2520ADSD</p> <p>Frequency: 100MHz, 125MHz, 156.25MHz</p> <p>Pin Connections: #1: OE #2: NC #3: GND #4: Output #5: OutputN #6: Vcc</p> <p>Function: #1 Input, #4, #5 Output condition: Open or "H" Oscillation out, High-Z</p> <p>Recommended Land Pattern (Top View)</p>	<p>Dimensions</p> <p>Model Code: DS3225AKSK, DS3225AKSJ, DS3225ADSD</p> <p>Frequency: 100MHz, 125MHz, 156.25MHz</p> <p>Pin Connections: #1: OE #2: NC #3: GND #4: Output #5: OutputN #6: Vcc</p> <p>Function: #1 Input, #4, #5 Output condition: Open or "H" Oscillation out, High-Z</p> <p>Recommended Land Pattern (Top View)</p>

High-precision SMD TCXO

Under Development

DA2016AS/DB2016AS

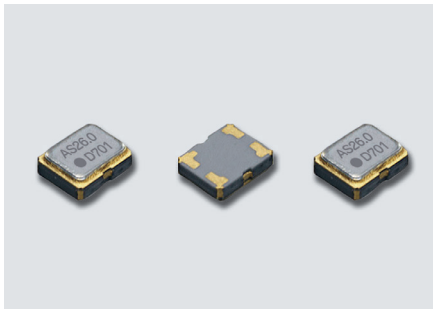

Actual size

■ Features

- Supply Voltage : 1.8V/2.6V/2.8V/3.0V/3.3V
- Available Frequency range: 26MHz, 52MHz
- Clipped Sinewave
- Low phase noise
- Single package structure
- AEC-Q200 Compliant (Option: Equivalent to AEC-Q100)

■ Applications

- GPS/GNSS, Mobile devices, Satellite communication devices, industrial wireless communication devices, etc.



■ Standard Specification

Item	Type	VC-TCXO DA2016AS	TCXO DB2016AS
	Standard Frequency		26MHz/52MHz
Supply Voltage Range		+1.68 to +3.5V	
Supply Voltage		+1.8V/+2.6V/+2.8V/+3.0V+3.3V	
Current Consumption		+1.5mA max. (26MHz) / +2.0mA max. (52MHz)	
Output Level		0.8Vp-p min. (Clipped Sinewave / DC-coupled)	
Output Load		10kΩ//10pF	
Frequency Stability		±1.5×10 ⁻⁶ max. (After 2 reflows)	
Tolerance			
vs. Temperature		±1.0×10 ⁻⁶ , ±2.5×10 ⁻⁶ max. / -30 to +85°C ±1.0×10 ⁻⁶ , ±2.5×10 ⁻⁶ max. / -40 to +85°C (Option)	±0.5×10 ⁻⁶ , ±2.5×10 ⁻⁶ max. / -30 to +85°C ±0.5×10 ⁻⁶ , ±2.5×10 ⁻⁶ max. / -40 to +85°C (Option)
vs. Supply Voltage		±0.2×10 ⁻⁶ max. (Vcc ±5%)	
vs. Load Variation		±0.2×10 ⁻⁶ max. (10kΩ//10pF ±10%)	
vs. Aging		±1.0×10 ⁻⁶ max. /year	
Frequency Control			
Control Sensitivity		±3.0×10 ⁻⁶ , ±5.0×10 ⁻⁶ /Vcont=+1.4V±1.0V @Vcc≥+2.6V ±3.0×10 ⁻⁶ , ±5.0×10 ⁻⁶ /Vcont=+0.9V±0.6V @Vcc=+1.8V	-
Response Slope		Positiv	-
Start up Time		2.0ms max.	
Phase Noise		[26MHz]	[52MHz]
Offset 100Hz		-115dBc/Hz max.	-105dBc/Hz max.
Offset 1kHz		-130dBc/Hz max.	-125dBc/Hz max.
Offset 10kHz		-150dBc/Hz max.	-145dBc/Hz max.
Offset 100kHz		-155dBc/Hz max.	-150dBc/Hz max.
Packing Unit(1)		3000pcs./reel (φ180)	

(1) Moisture prevention packing is unnecessary.
Moisture Sensitivity Level:Level1 (IPC/JEDEC J-STD-033)

Consult our sales representative for other specifications

[mm]

■ Dimensions

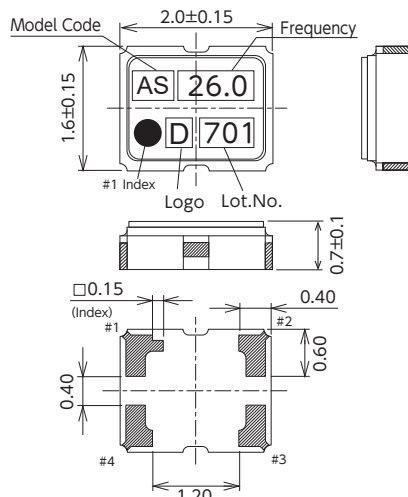

■ Recommended Land Pattern

(Top View)

Model Code
DA2016AS : AS (VC-TCXO)
DB2016AS : BS (TCXO)

Pin Connections

Pin No.	Connection
#1	Vcont (VC-TCXO)/ GND (TCXO)
#2	GND
#3	Output
#4	Vcc

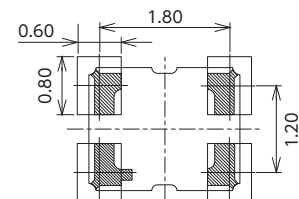

Quartz Devices

Crystal resonators

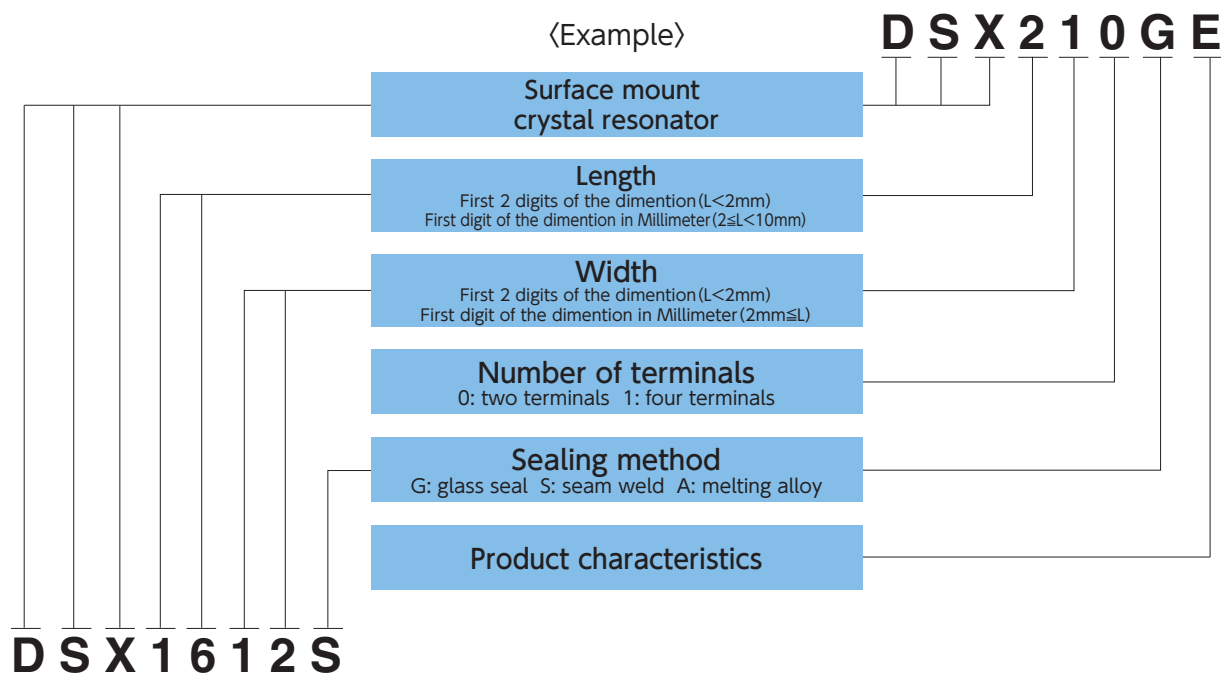
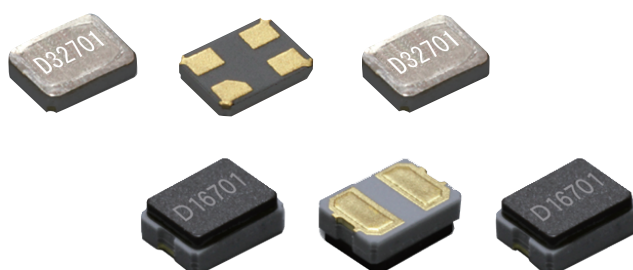

Crystal Resonators

Description

●MHz Band Crystal Resonators

A resonator using thickness-shear mode and has high stability during temperature variations. There are many packages and sizes available for various applications.

●kHz Band Crystal Resonators(Tuning Fork Crystal Resonators)

A resonator with low power consumption and a tuning fork shaped crystal blank. Common application includes watches and mobile phones.

Terminology

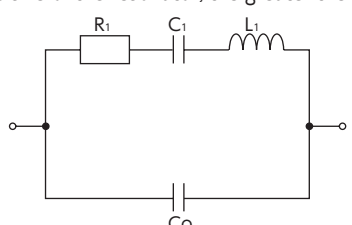
Fundamental Crystal Resonators	Crystal resonator designed to oscillate in the lowest-order (fundamental) oscillation mode.
Overtone Crystal Resonators	Crystal resonator designed to oscillate in the overtone oscillation mode (third, fifth, and seventh).
Overtone Order	Desired order of vibration mode, (odd) integer multiples of the fundamental mode.
Vibration Mode	One factor which determines the mechanical vibration behavior of a crystal blank is cutting angle. Examples of such vibration behaviors are thickness-shear mode and flexure mode.
Nominal Frequency	The specified center frequency of the crystal.
Load Capacitance	The effective external capacitance that determines the resonance frequency of a crystal resonator. When this capacitance is small, the crystal resonator is vulnerable to changes in the circuit characteristics, thus deteriorating the frequency stability.
Drive Level	Loading condition of crystal resonator, which is determined by electric current or power applied to the crystal blank. Electric power P is determined by the following equation: $P= I^2 \cdot R_1$, where I represents electric current and R1 represents series resistance.
Series Resistance	The resistance of the crystal at the series resonance frequency, also called the equivalent series resistance (ESR).
Frequency Tolerance (Crystal Resonators)	Allowable deviation from nominal at room temperature (25 deg.C), indicated in parts per million ($\times 10^{-6}$).
Frequency Characteristics over Temperature (Crystal Resonators)	Allowable deviation of frequency at room temperature, in parts per million ($\times 10^{-6}$). This is the maximum value within the operating temperature range.
Aging	The frequency change of the crystal operated at specific conditions for a certain period of time.
Operating Temperature Range	Temperature range over which the crystal resonator can be operated within allowable deviation range.
Storage Temperature Range	Temperature range, which crystal resonator can be stored at without any deterioration or damage independently.
Turnover Temperature	The temperature at the peak of the parabolic curve that a crystal in kHz shows with temperature. It is expected that the crystal will have a steady oscillation if the peak temperature is within the working temperature range.
Parabolic Coefficient	The temperature co-efficient of a parabolic curve shown in frequency vs. temperature.
Plastic-encapsulated (SMD) type	Crystal resonators encapsulated with resin.
Cylindrical type	Crystal resonators in cylindrical constructions, which are generally in kHz frequency range.
Equivalent Circuit to Crystal Resonator	<p>An equivalent circuit near the resonance point of the crystal resonator is shown below. It consists of a series circuit including series motional inductance (L1), series capacitance (C1) and series resistance (R1), with the resonator's terminal-to-terminal capacitance (shunt capacitance: C0) connected in parallel with the series circuit. The smaller the size of the resonator, the greater the average values of R1 and L1.</p> 

Oscillation Circuit

Oscillation Circuit of Crystal Resonator

Oscillation Circuit of Fundamental Mode

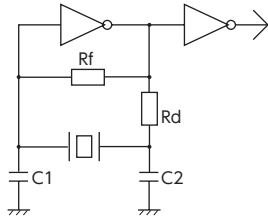

Oscillation Circuit of Overtone Mode

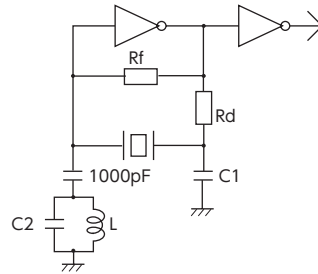

VCXO Circuit

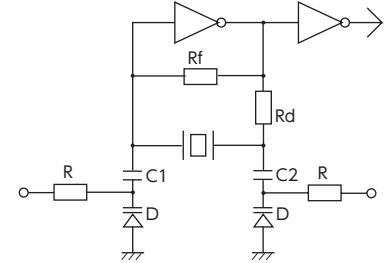

Oscillation Circuit of Fundamental Mode :

A circuit that allows the crystal resonator to oscillate in the fundamental mode.

Oscillation Circuit of Overtone Mode :

A circuit that allows the crystal resonator to oscillate in a high-order oscillation mode (overtone mode). (However, the circuit can be used at the composition of oscillation circuit of fundamental mode.)

VCXO Circuit :

An oscillation circuit with a frequency control function that utilizes the load capacitance characteristic of the crystal resonator.

Tips for Circuit Design

[IC Selection]

Selecting an IC according to the oscillation frequency.

(Example) 4069UB : From the kHz range to around 8 MHz
 7WU04 : 4 to 30MHz
 7WHU04 : 20 to 60MHz

[Feedback Resistance]

The feedback resistance for DC bias is necessary to continue the oscillation of a resonator. Generally, a resistance of 10 MΩ and above is used for oscillation in the kHz range, and a resistance of 1 MΩ and above is used for oscillation in the MHz range.

For overtone oscillation, a resistance of 1 kΩ may be used.

[Control Resistance]

Limits the current that flows into resonator, adjusts the negative resistance and drive level, prevents abnormal oscillation of resonator and suppresses frequency fluctuations.

[Capacitor C1, C2]

Adjusts the negative resistance and drive level, prevents abnormal oscillation of resonator.

[Bypass Capacitor]

This component is required to lower the impedance of the power-supply system inserted between the power-supply pin and ground pin of the IC. Mount as closely as possible to the IC, using a bypass capacitor with a capacitance suitable for the oscillation frequency.

(Example) kHz range : 10 to 100 μF
 MHz range : 0.01 to 0.1 μF

[Line Pattern]

Mount parts of a oscillation circuit as closely as possible to the IC and don't put signal line of the oscillator circuit closely or cross another signal line.

Oscillation Circuit

Confirmation on Operation of Oscillation Circuit

[Negative Resistance]

As the figure shows, raise one end of the crystal resonator from the oscillation circuit and insert a resistor (R_s). Change the value of the inserted resistor (R_s). The value at which oscillation stops represents negative resistance. KDS measures the value not only at room temperature but also at low temperature, at high temperature and regards the lowest value as the negative resistance. The negative resistance value of the circuit should generally be at least five times the standard series resistance.

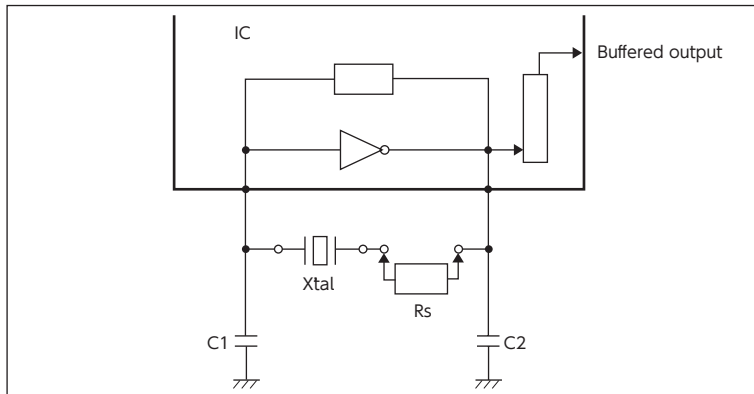

Measurement Circuit for Negative Resistance

[Load Capacitance]

Minimize the difference of the oscillation frequency by making the load capacitance of a oscillation circuit and that of a resonator equal.

[Drive Level]

Absolute Maximum Value ; See "Drive Level" in the table of each page.
The adequate drive level differs according to the crystal resonator type and overtone order.

MHz Band Crystal Resonators

Fundamental Mode: $300\mu\text{W}$ max., $200\mu\text{W}$ max., $100\mu\text{W}$ max. Overtone Mode: 1mW max., $500\mu\text{W}$ max.

Tuning Fork Crystal Resonators

$2\mu\text{W}$ max., $1\mu\text{W}$ max.

The smaller a resonator becomes, the tighter its specification becomes.

(Measurement Method)

Calculation based on the measured amperage flowing through a resonator and the resistance of that with a high-frequency current probe.

$$\text{Drive Level } P = (I/2\sqrt{2})^2 \cdot R$$

[Inquiry About The Oscillation Circuit]

Regarding inquiries concerning oscillation circuit and its matching with the ICs you are using, please directly contact our sales department or leave us an e-mail from our website(click "CONTACT US" from the top page → select "TECHNICAL SUPPORT").

Cut Angle and Frequency Characteristics over Temperature

Temperature Characteristics for Various Cuts

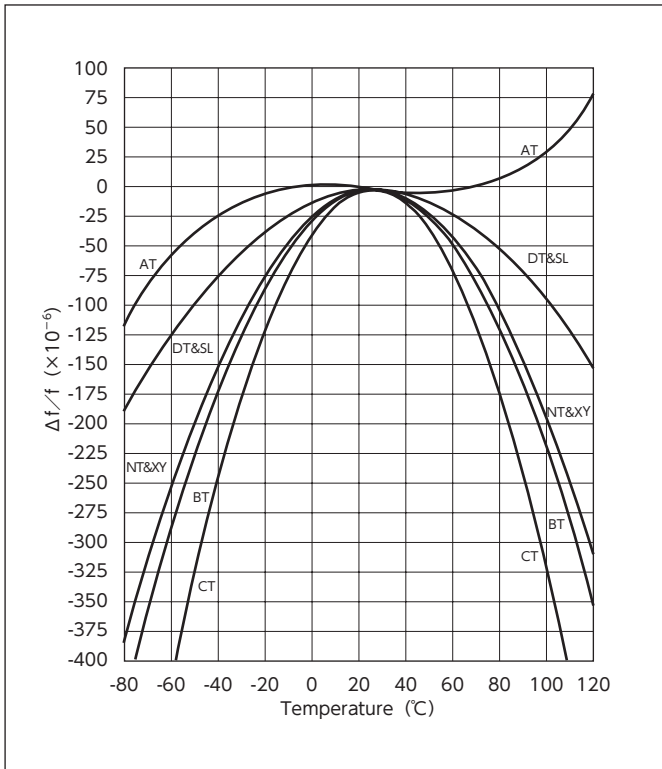

Temperature Characteristics for AT Cuts

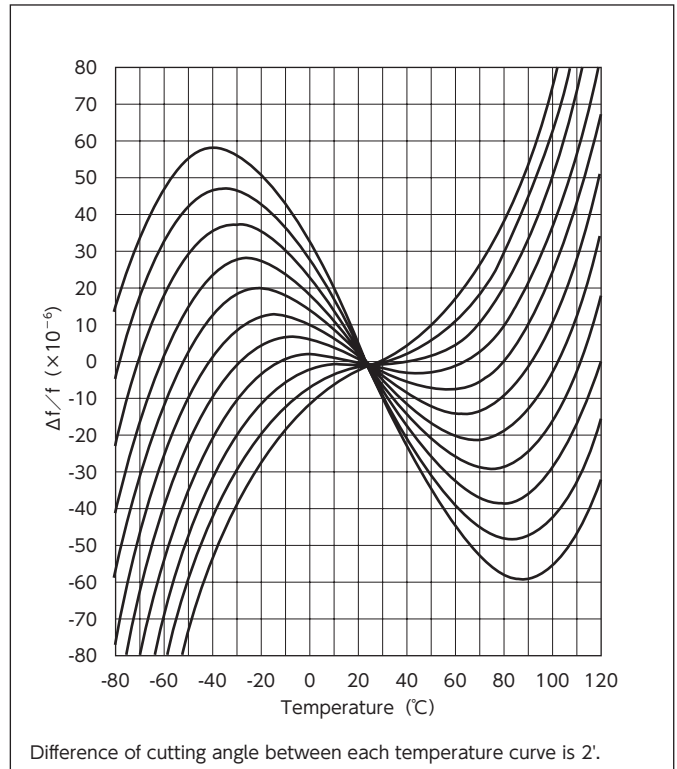

Temperature Characteristics for BT Cuts

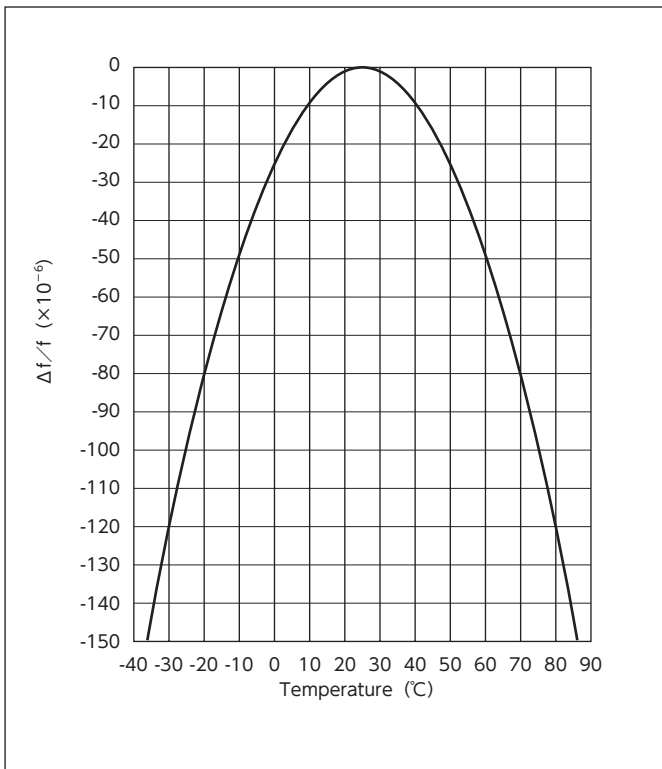

Temperature Characteristics for Tuning Fork Crystal Resonator

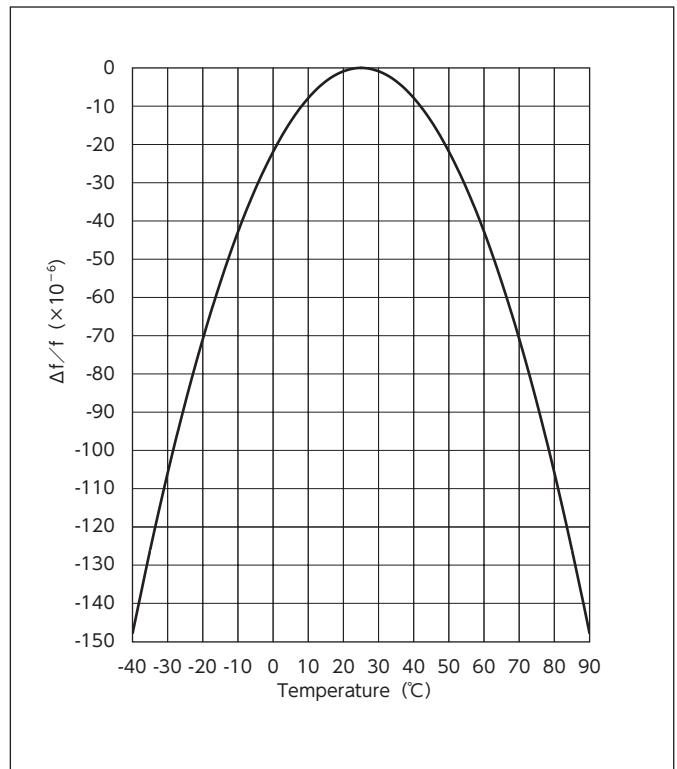

SMD Crystal Resonators / MHz Band Crystal Resonators

DSX1210A

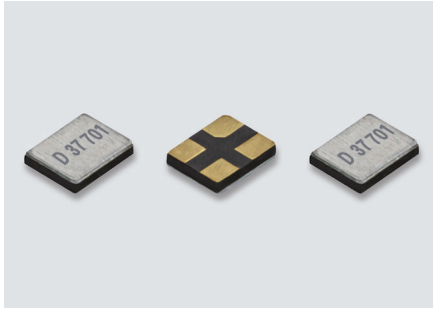

Actual size □

■ Features

- 1210 size ultra miniature and lightweight SMD crystal resonator with a low profile of 0.28mm
- High precision and high reliability
(Frequency aging specification of $\pm 1 \times 10^{-6}$ /1 year or $\pm 3 \times 10^{-6}$ /5 years is available for cell phone or wireless communication systems etc.)
- Allowing for high density surface mounting.
- AEC-Q200 Compliant



■ Applications

- Small mobile devices for next generation such as mobile communications, short-range wireless modules, digital AV equipment and PC.
- Wearable devices

■ Standard Specification

Item	Type	DSX1210A			
		32MHz	37.4MHz / 38.4MHz / 40MHz	48MHz/52MHz	76.8MHz/80MHz
Frequency Range		32MHz	37.4MHz / 38.4MHz / 40MHz	48MHz/52MHz	76.8MHz/80MHz
Overtone Order		Fundamental			
Load Capacitance		8pF, 10pF, 12pF			
Drive Level		10 μ W (100 μ W max.)			
Frequency Tolerance		$\pm 10 \times 10^{-6}$, $\pm 20 \times 10^{-6}$ (at 25°C)			
Series Resistance		100 Ω max.	60 Ω max.	40 Ω max.	30 Ω max.
Frequency Characteristics over Temperature		$\pm 12 \times 10^{-6}$, $\pm 30 \times 10^{-6}$ / -30 to +85°C (Ref. To 25°C)			
Storage Temperature Range		-40 to +85°C			
Packing Unit (1)		3000pcs./reel ($\phi 180$)			

(1) Moisture prevention packing is unnecessary.
Moisture Sensitivity Level:LEVEL1 (IPC/JEDEC J-STD-033)

Consult our sales representative for other specifications.

[mm]

■ Dimensions

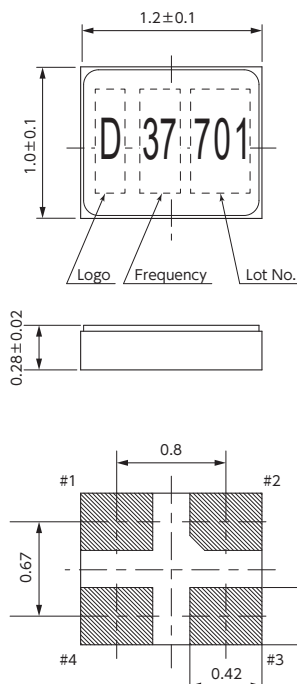

■ Internal Connections

<Top View>

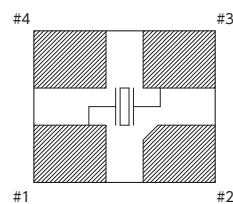

1 & # 3 connected to quartz element
2 & # 4 connected to the cover

■ Recommended Land Pattern

<Top View>

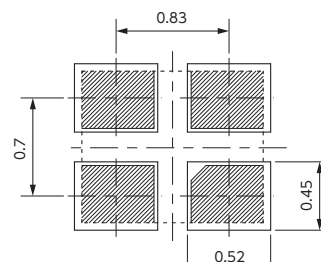

SMD Crystal Resonators / MHz Band Crystal Resonators

DSX1612S

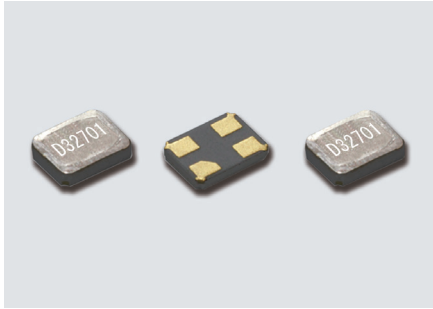

Actual size □

■ Features

- 1612 size ultra miniature and lightweight SMD crystal resonator with a low profile of 0.35 mm.
- High precision and high reliability (Frequency aging specification of $\pm 1 \times 10^{-6}$ /1 year or $\pm 3 \times 10^{-6}$ /5 years is available for cell phone or wireless communication systems etc.)
- Allowing for high density surface mounting.

■ Applications

- Small mobile devices for next generation such as mobile communications, short-range wireless modules, digital AV equipment and PC.
- Wearable devices



■ Standard Specification

Item	Type	DSX1612S		
Frequency Range		24 to 32MHz	32 to 40MHz	40 to 54MHz
Overtone Order		Fundamental		
Load Capacitance		8pF, 10pF, 12pF		
Drive Level		10 μ W (100 μ W max.)		
Frequency Tolerance		$\pm 10 \times 10^{-6}$, $\pm 20 \times 10^{-6}$ (at 25°C)		
Series Resistance		100 Ω max.	50 Ω max.	
Frequency Characteristics over Temperature		$\pm 15 \times 10^{-6}$, $\pm 30 \times 10^{-6}$ / -30 to +85°C (Ref. To 25°C)		
Storage Temperature Range		-40 to +85°C		
Packing Unit (1)		3000pcs./reel ($\phi 180$)		

(1) Moisture prevention packing is unnecessary.
Moisture Sensitivity Level: LEVEL1 (IPC/JEDEC J-STD-033)

Consult our sales representative for other specifications.

[mm]

■ Dimensions

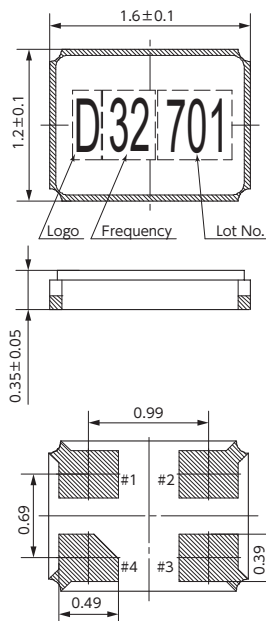

■ Internal Connections

<Top View>

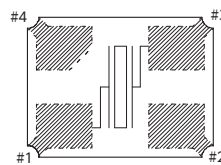

- # 1 & # 3 connected to quartz element
- # 2 connected to the cover
- # 4 open (unconnected)
- # 2 & # 4 recommended GND connection

■ Recommended Land Pattern

<Top View>

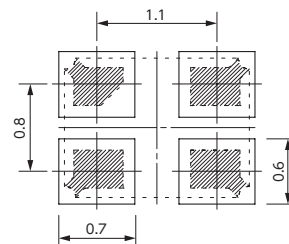

SMD Crystal Resonators / MHz Band Crystal Resonators

DSX211S/DSX211SH/DSX221SH/DSX321SH

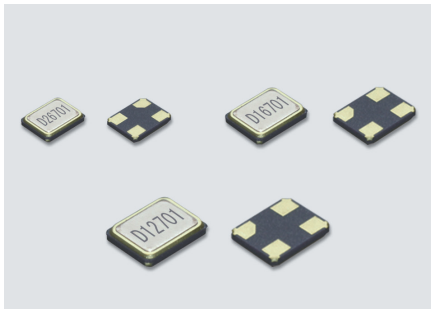

Actual size DSX211S/SH DSX221SH
DSX321SH

■ Features

- Miniature and lightweight SMD crystal resonator
DSX211S/SH : 2016 size 0.45mm height
DSX221SH : 2520 size 0.45mm height
DSX321SH : 3225 size 0.65mm height
- Excellent heat resistance, High precision and high reliability
- Offers a wide range of frequencies
DSX211S : 76.8MHz, 80MHz, 96MHz
DSX211SH : 16MHz to 60MHz
DSX221SH : 12MHz to 54MHz
DSX321SH : 12MHz to 50MHz
- AEC-Q200 Compliant (except for DSX211S)
- Frequency Characteristics over Temperature
 $\pm 50 \times 10^{-6} / -40$ to $+105^\circ\text{C}$ is available for Industrial Equipment.



■ Applications

- Telecommunication products, short-range wireless modules and other small devices such as DVC, DSC, PC.
- Automotive applications such as multimedia devices (AEC-Q200 Compliant).
- Industrial equipment

■ Standard Specification

Item	Type	DSX211SH	DSX211S	DSX221SH	DSX321SH	
Frequency Range		16 to 30MHz / 30 to 60MHz	76.8MHz/80MHz/96MHz	12 to 24MHz / 24 to 30MHz / 30 to 54MHz	12 to 20MHz / 20 to 32MHz / 32 to 50MHz	
Overtone Order		Fundamental				
Load Capacitance		8pF, 10pF, 12pF				
Drive Level		10 μW (100 μW max.)	10 μW (400 μW max.)	10 μW (200 μW max.)		
Frequency Tolerance		$\pm 20 \times 10^{-6}$ (at 25 $^\circ\text{C}$)				
Series Resistance		100 Ω max. / 50 Ω max.	30 Ω max.	120 Ω max. / 50 Ω max.	40 Ω max. / 80 Ω max.	50 Ω max. / 40 Ω max.
Frequency Characteristics over Temperature		$\pm 30 \times 10^{-6} / -30$ to $+85^\circ\text{C}$ (Ref. to 25 $^\circ\text{C}$)				
Storage Temperature Range		-40 to +85 $^\circ\text{C}$				
Packing Unit (1)		3000pcs./reel($\phi 180$)				

(1) Moisture prevention packing is unnecessary.
Moisture Sensitivity Level: LEVEL1 (IPC/JEDEC J-STD-033)

Consult our sales representative for other specifications.

■ DSX211S/DSX211SH [mm]

■ DSX221SH [mm]

■ DSX321SH [mm]

[mm]

■ Dimensions	■ Dimensions	■ Dimensions
<p>2.0± 0.1 1.6± 0.1 0.45± 0.05 1.275 0.975 0.575 0.475</p>	<p>2.5± 0.15 2.0± 0.15 0.45± 0.05 1.6 1.25 0.7 0.55</p>	<p>3.2± 0.1 2.5± 0.1 0.65± 0.1 2.1 1.5 0.9 0.8</p>
<p>■ Internal Connections (Top View)</p> <p>#1 & #3 connected to quartz element #2 & #4 connected to the cover #2 & #4 recommended GND connection</p>	<p>■ Internal Connections (Top View)</p> <p>#1 & #3 connected to quartz element #2 & #4 connected to the cover #2 & #4 recommended GND connection</p>	<p>■ Internal Connections (Top View)</p> <p>#1 & #3 connected to quartz element #2 & #4 connected to the cover #2 & #4 recommended GND connection</p>
<p>■ Recommended Land Pattern (Top View)</p> <p>1.4 1.1 0.9 0.8</p>	<p>■ Recommended Land Pattern (Top View)</p> <p>1.75 1.3 1.15 1.0</p>	<p>■ Recommended Land Pattern (Top View)</p> <p>2.2 1.7 1.4 1.2</p>

SMD Crystal Resonators / MHz Band Crystal Resonators

DSX211G

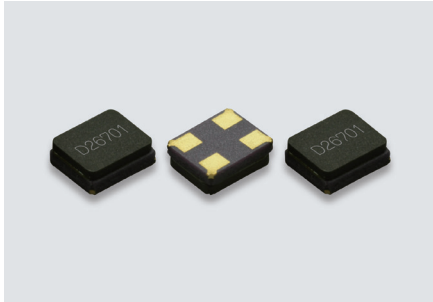

Actual size

■ Features

- 2016 size miniature and lightweight
SMD crystal resonator with a low profile of 0.65mm.
- High precision and high reliability
- Offers a wide range of frequencies from 20MHz up to 64MHz.
- AEC-Q200 Compliant
- Frequency Characteristics over Temperature
 $\pm 50 \times 10^{-6} / -40$ to $+105^\circ\text{C}$ is available for Industrial Equipment.

■ Applications

- Telecommunication products and other small devices such as DVC, DSC, PC, USB.
- Automotive applications such as multimedia devices (AEC-Q200 Compliant)
- Industrial equipment

■ Standard Specification

Item	Type	DSX211G			
		20 to 24MHz	24 to 30MHz	30 to 36MHz	36 to 64MHz
Frequency Range		20 to 24MHz	24 to 30MHz	30 to 36MHz	36 to 64MHz
Overtone Order		Fundamental			
Load Capacitance		8pF, 10pF, 12pF			
Drive Level		10 μW (100 μW max.)			
Frequency Tolerance		$\pm 20 \times 10^{-6}$ (at 25 $^\circ\text{C}$)			
Series Resistance		200 Ω max.	150 Ω max.	120 Ω max.	80 Ω max.
Frequency Characteristics over Temperature		$\pm 30 \times 10^{-6} / -30$ to $+85^\circ\text{C}$ (Ref. to 25 $^\circ\text{C}$)			
Storage Temperature Range		-40 to $+85^\circ\text{C}$			
Packing Unit (1)		3000pcs./reel ($\phi 180$)			

(1) Moisture prevention packing is unnecessary.
Moisture Sensitivity Level: LEVEL1 (IPC/JEDEC J-STD-033)

Consult our sales representative for other specifications.

[mm]

■ Dimensions

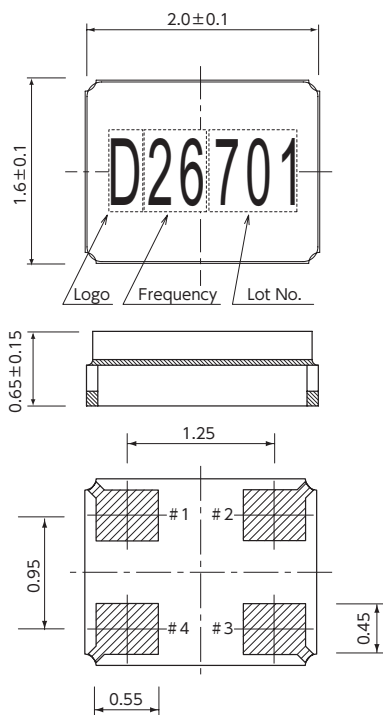

■ Internal Connections

<Top View>

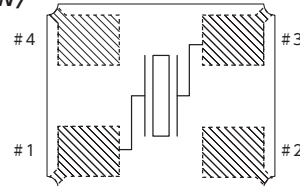

#1 & #3 connected to quartz element
#2 & #4 GND connected or N.C. available

■ Recommended Land Pattern

<Top View>

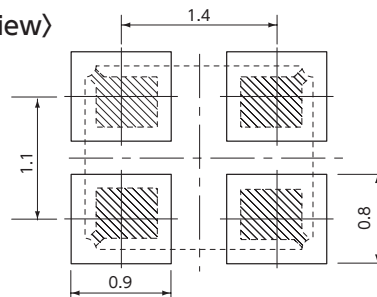

SMD Crystal Resonators / MHz Band Crystal Resonators

DSX321G

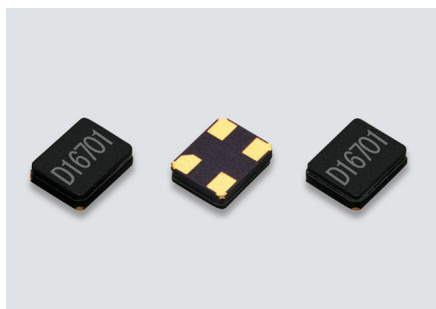

Actual size

■ Features

- 3225 size miniature and lightweight SMD crystal resonator.
Height DSX321G (over 12MHz): 0.75mm
DSX321G (12MHz or under): 0.85mm
- Excellent heat resistance, High precision and high reliability (Frequency aging specification of $\pm 1 \times 10^{-6}$ /1 year or $\pm 3 \times 10^{-6}$ /5 years is available for cell phone or wireless communication systems etc.)
- Offers a wide range of frequencies from 7.9MHz up to 64MHz.
- AEC-Q200 Compliant
- Frequency Characteristics over Temperature $\pm 50 \times 10^{-6}$ / -40 to +105°C is available for Industrial Equipment.



RoHS Compliant

■ Applications

- Telecommunication products, short-range wireless modules and other small devices such as DVC, DSC, PC.
- Automotive applications such as Bluetooth, wireless LAN, GPS/GNSS, RKE (Remote Keyless Entry), safety controls and multimedia devices (AEC-Q200 Compliant)
- Industrial equipment

■ Standard Specification

Item	Type	DSX321G						
		7.9 to 9MHz	9 to 9.8MHz	9.8 to 11MHz	11 to 12MHz	12 to 20MHz	20 to 27MHz	27 to 64MHz
Frequency Range		7.9 to 9MHz	9 to 9.8MHz	9.8 to 11MHz	11 to 12MHz	12 to 20MHz	20 to 27MHz	27 to 64MHz
Overtone Order		Fundamental						
Load Capacitance		8pF, 10pF, 12pF						
Drive Level		10μW (200μW max.)						
Frequency Tolerance		$\pm 20 \times 10^{-6}$ (at 25°C)						
Series Resistance		400Ω max.	300Ω max.	150Ω max.	100Ω max.	80Ω max.	60Ω max.	50Ω max.
Frequency Characteristics over Temperature		$\pm 30 \times 10^{-6}$ / -30 to +85°C (Ref. to 25°C)						
Storage Temperature Range		-40 to +85°C						
Packing Unit (1)		3000pcs./reel (φ180)						

(1) Moisture prevention packing is unnecessary.
Moisture Sensitivity Level: LEVEL1 (IPC/JEDEC J-STD-033)

Consult our sales representative for other specifications.

■ DSX321G (12MHz or under)

[mm] ■ DSX321G (over 12MHz)

[mm]

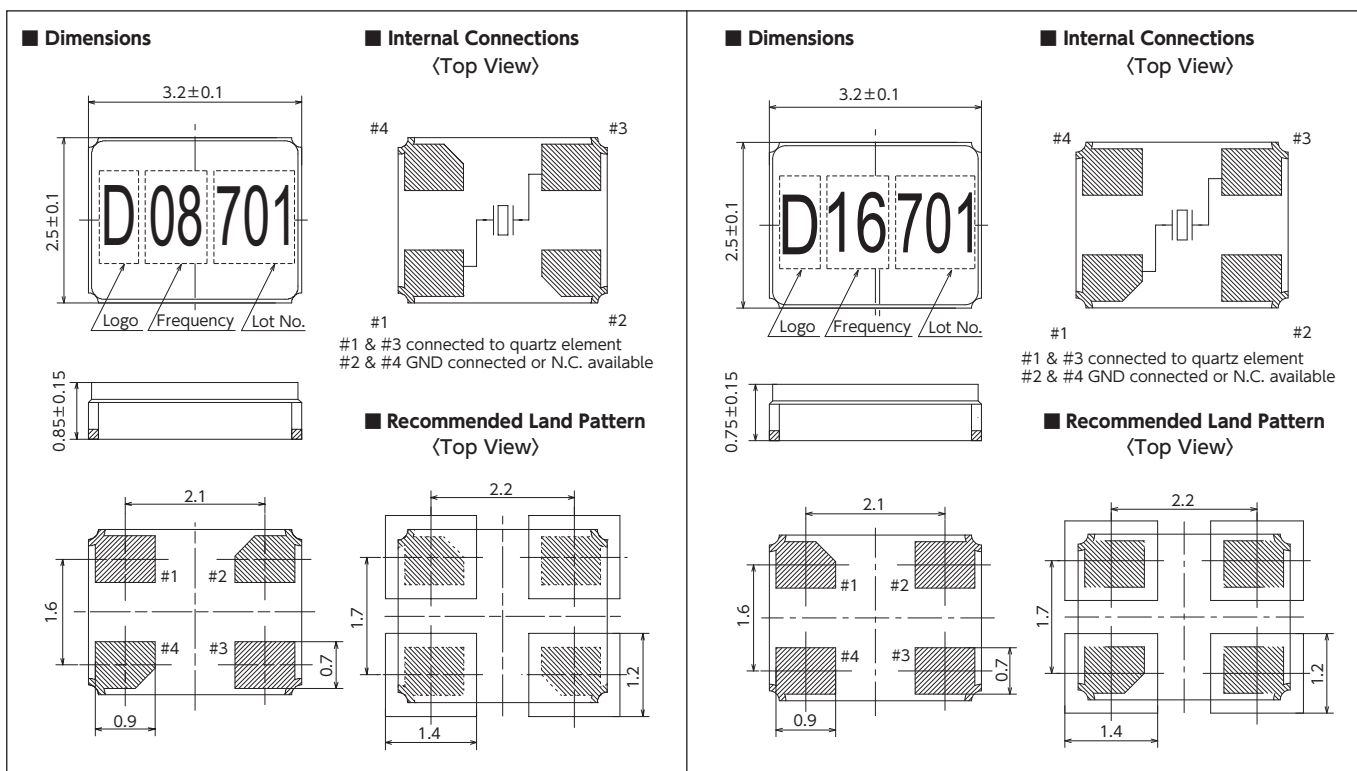

SMD Crystal Resonators with dedicated temperature sensor / MHz Band Crystal Resonators

DSR1210ATH/DSR1612ATH



Actual size DSR1210ATH □ DSR1612ATH □

■ Features

- DSR1210ATH: 1210size, height 0.45mm
- DSR1612ATH: 1612size, height 0.55mm
- Built-in NTC thermistor

■ Applications

- Mobile phones
- GPS/GNSS
- Wearable devices



■ Standard Specification

Item	Type	DSR1210ATH	DSR1612ATH
Frequency Range		76.8MHz	38.4MHz / 52MHz / 76.8MHz
Overtone Order		Fundamental	
Load Capacitance		6pF, 7pF, 8pF	
Drive Level		10μW (100μW max.)	
Frequency Tolerance		±10×10 ⁻⁶ (at 25°C)	
Series Resistance		80Ω max.	
Frequency Characteristics over Temperature		±12×10 ⁻⁶ / -30 to +85 °C	
Storage Temperature Range		-40 to +125 °C	
Thermistor Resistance		100kΩ (at +25°C)	22kΩ / 100kΩ(at +25°C)
Thermistor B-constant		4250K (+25°C to +50°C)	3380K / 4250K(+25°C to +50°C)
Packing Unit (1)		3000pcs./reel (φ 180)	

(1) Moisture prevention packing is unnecessary.
Moisture Sensitivity Level : LEVEL 1 (IPC/JEDEC J-STD-033)

Consult our sales representative for other specifications.

■ DSR1210ATH

[mm]

■ DSR1612ATH

[mm]

■ Dimensions

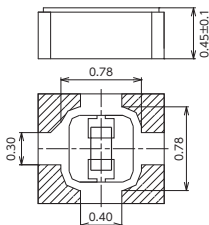
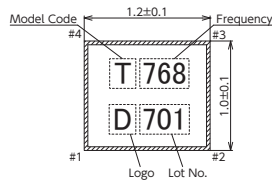

■ Internal Connections

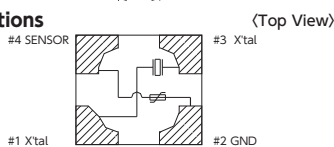

■ Recommended Land Pattern

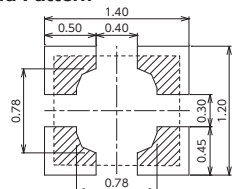

■ Dimensions

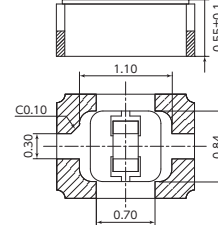
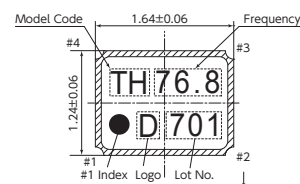

■ Internal Connections

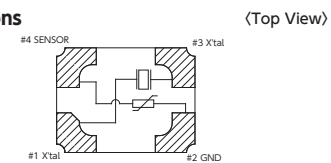

■ Recommended Land Pattern

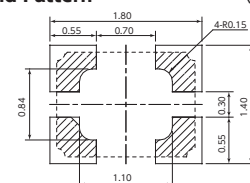

SMD Crystal Resonators with dedicated temperature sensor / MHz Band Crystal Resonators

DSR211STH/DSR221STH

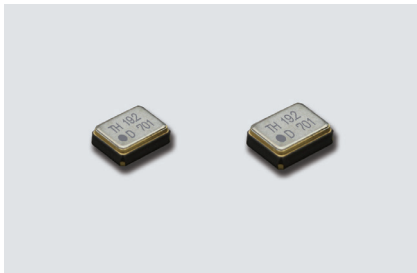

Actual size DSR211STH □ DSR221STH □

■ Features

- DSR211STH: 2016size, height 0.7mm (19.2MHz / 26MHz)
0.6mm (38.4MHz)
- DSR221STH: 2520size height 0.9mm
- Built-in NTC thermistor

■ Applications

- Mobile phones
- GPS/GNSS
- Wearable devices
- UWB



■ Standard Specification

Item	Type	DSR211STH	DSR221STH
Frequency Range		19.2MHz / 26MHz / 38.4MHz / 55.2MHz	19.2MHz / 26MHz
Overtone Order		Fundamental	
Load Capacitance		6pF, 7pF, 8pF	
Drive Level		10 μ W (100 μ W max.)	
Frequency Tolerance		$\pm 10 \times 10^{-6}$ (at 25°C)	
Series Resistance		80 Ω max.	
Frequency Characteristics over Temperature		$\pm 12 \times 10^{-6}$ / -30 to +85 °C	
Storage Temperature Range		-40 to +125 °C	
Thermistor Resistance		10k Ω / 22k Ω / 100k Ω (at +25°C)	
Thermistor B-constant		3435K (+25 to +85°C) / 3380K / 4250K (+25 to +50°C)	
Packing Unit (1)		3000pcs./reel (ϕ 180)	

(1) Moisture prevention packing is unnecessary.
Moisture Sensitivity Level : LEVEL 1 (IPC/JEDEC J-STD-033)

Consult our sales representative for other specifications.

■ DSR211STH

■ DSR221STH

[mm]

■ Dimensions

■ Internal Connections

(Top View)

■ Recommended Land Pattern

(Top View)

■ Dimensions

■ Internal Connections

(Top View)

■ Recommended Land Pattern

(Top View)

SMD Tuning Fork Crystal Resonators / kHz Band Crystal Resonators

DST1210A

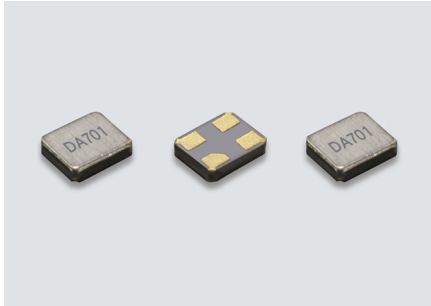

Actual size □

■ Features

- 1210 size ultra miniature SMD tuning fork crystal resonator with a low profile of 0.3mm
- A ceramic package with a metal lid providing high precision and reliability.
- Suitable for mobile communications and consumer devices.
- Metal lid connected to GND terminal to reduce EMI.

■ Applications

- Mobile communications and consumer devices, etc.
- Smart card and Wearable devices



■ Standard Specification

Item	Type	DST1210A
Frequency Range		32.768kHz
Load Capacitance		7pF, 9pF, 12.5pF
Drive Level		0.1 μW (0.2 μW max.)
Frequency Tolerance		±20×10 ⁻⁶ (at 25°C)
Series Resistance		80kΩ max.
Turnover Temperature		+25°C ±5°C
Parabolic Coefficient		-0.04×10 ⁻⁶ /°C ² max.
Operating Temperature Range		-40 to +85°C
Storage Temperature Range		-40 to +85°C
Shunt Capacitance		1.0pF typ.
Packing Unit (1)		3000pcs/reel (φ 180)

(1) Moisture prevention packing is unnecessary.
Moisture Sensitivity Level : LEVEL 1 (IPC/JEDEC J-STD-033)

Consult our sales representative for other specifications.

[mm]

■ Dimensions

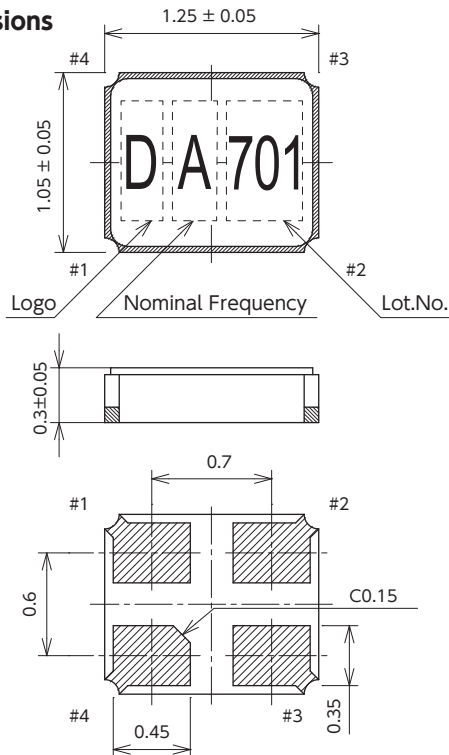

■ Internal Connections

<Top View>

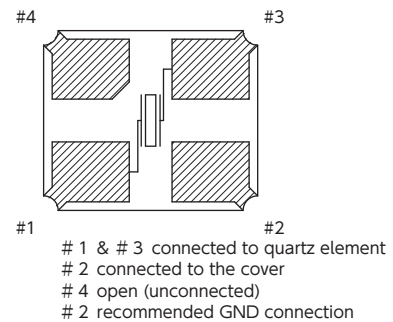

■ Recommended Land Pattern

<Top View>

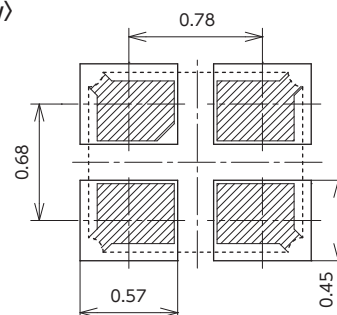

SMD Tuning Fork Crystal Resonators / kHz Band Crystal Resonators

DST1610A/DST210AC

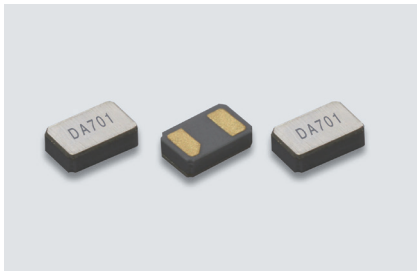

DST1610A Actual size

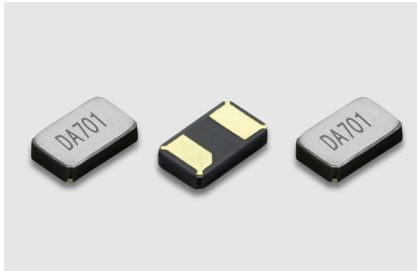

DST210AC Actual size

■ Features

- Ultra miniature SMD tuning fork crystal resonator
DST1610A: 1610size, height 0.45mm
DST210AC: 2012size, height 0.5mm
- A ceramic package with a metal lid providing high precision and reliability.
- Suitable for mobile communications and consumer devices.
- Series Resistance 50kΩ max. available.
- AEC-Q200 Compliant (DST210AC)



■ Applications

- Mobile communications and consumer devices, etc.

■ Standard Specification

Item	Type	DST1610A	DST210AC
Frequency Range		32.768kHz	
Load Capacitance		4pF, 6pF, 7pF, 9pF, 12.5pF	6pF, 7pF, 9pF, 12.5pF
Drive Level		0.1 μW (0.5 μW max.)	
Frequency Tolerance		±20×10 ⁻⁶ (at 25°C)	
Series Resistance		50/80kΩ max.	
Turnover Temperature		+25°C ±5°C	
Parabolic Coefficient		-0.04×10 ⁻⁶ /°C ² max.	
Operating Temperature Range		-40 to +85°C	
Storage Temperature Range		-40 to +85°C	
Shunt Capacitance		1.6/1.3pF typ.	
Packing Unit (1)		3000pcs/reel (φ 180)	

(1) Moisture prevention packing is unnecessary.
Moisture Sensitivity Level : LEVEL 1 (IPC/JEDEC J-STD-033)

Consult our sales representative for other specifications.

■ DST1610A

[mm]

■ DST210AC

[mm]

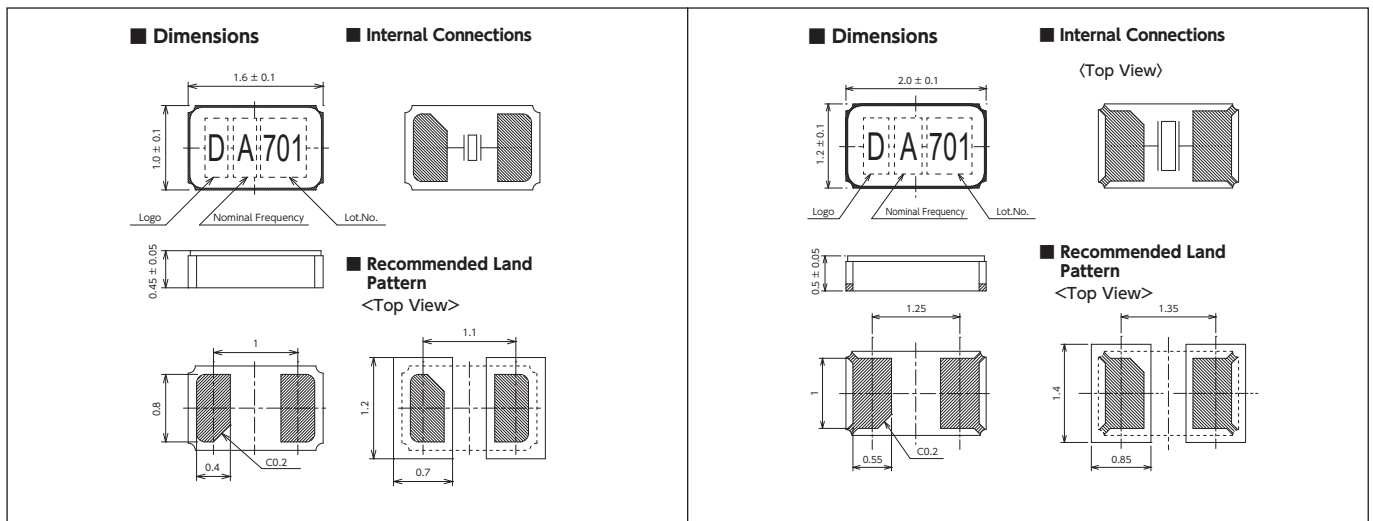

SMD Tuning Fork Crystal Resonators / kHz Band Crystal Resonators

DST310SA

NEW

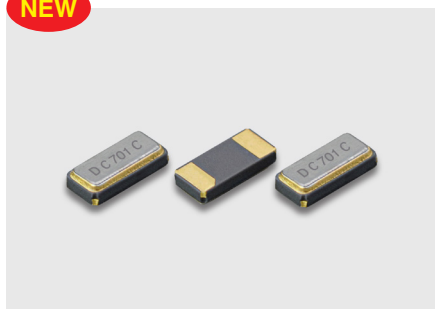

Actual size

■ Features

- 3215 size miniature and lightweight SMD tuning fork crystal resonator with a low profile of 0.75mm.
- A ceramic package with a metal lid providing high precision and reliability.
- Series Resistance 50kΩ max. available.
- AEC-Q200 Compliant

■ Applications

- Mobile communications, radio-controlled clock, digital home appliances.
- Automotive applications such as multimedia devices (AEC-Q200 Compliant).



■ Standard Specification

Item	Type	DST310SA
Frequency Range		32.768kHz
Load Capacitance		6pF, 7pF, 9pF, 12.5pF
Drive Level		0.1μW (0.5μW max.)
Frequency Tolerance		±20×10 ⁻⁶ (at 25°C)
Series Resistance		50kΩ max.
Turnover Temperature		+25°C±5°C
Parabolic Coefficient		-0.04×10 ⁻⁶ /°C ² max.
Operating Temperature Range		-40 to +85°C
Storage Temperature Range		-55 to +85°C
Shunt Capacitance		1.7pF typ.
Packing Unit (1)		3000pcs./reel (φ180)

(1) Moisture prevention packing is unnecessary.
Moisture Sensitivity Level : LEVEL 1 (IPC/JEDEC J-STD-033)

Consult our sales representative for other specifications.

[mm]

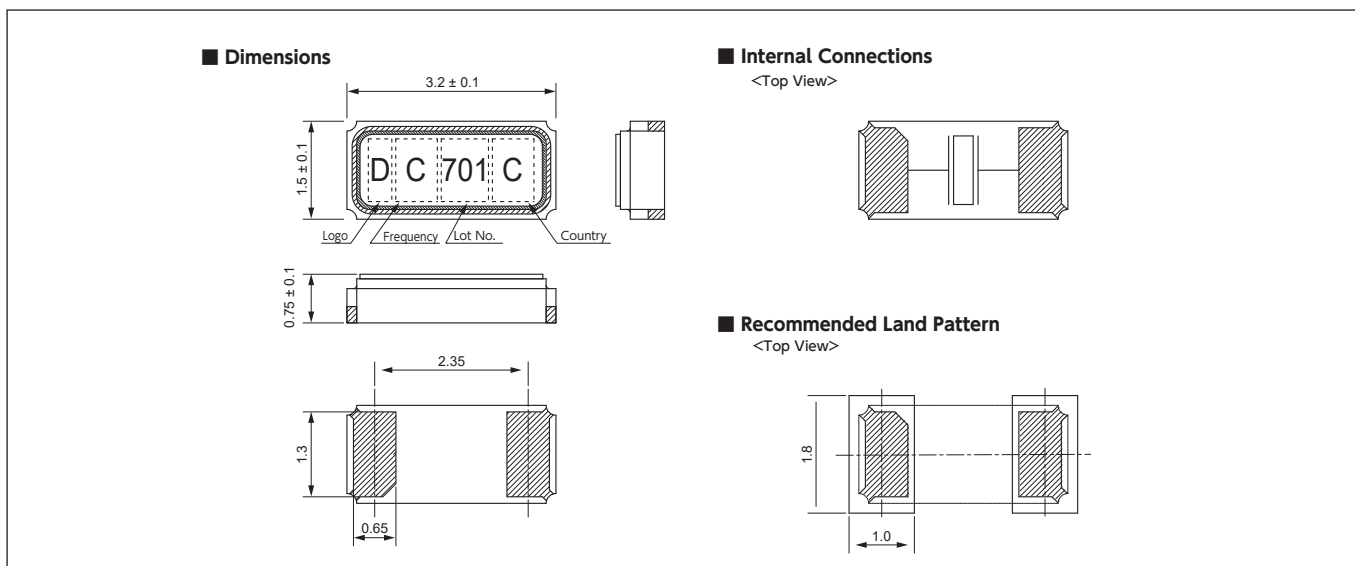

MEMO



A series of horizontal dashed lines for writing, filling most of the page below the 'MEMO' header.

Quartz Devices

Crystal oscillators

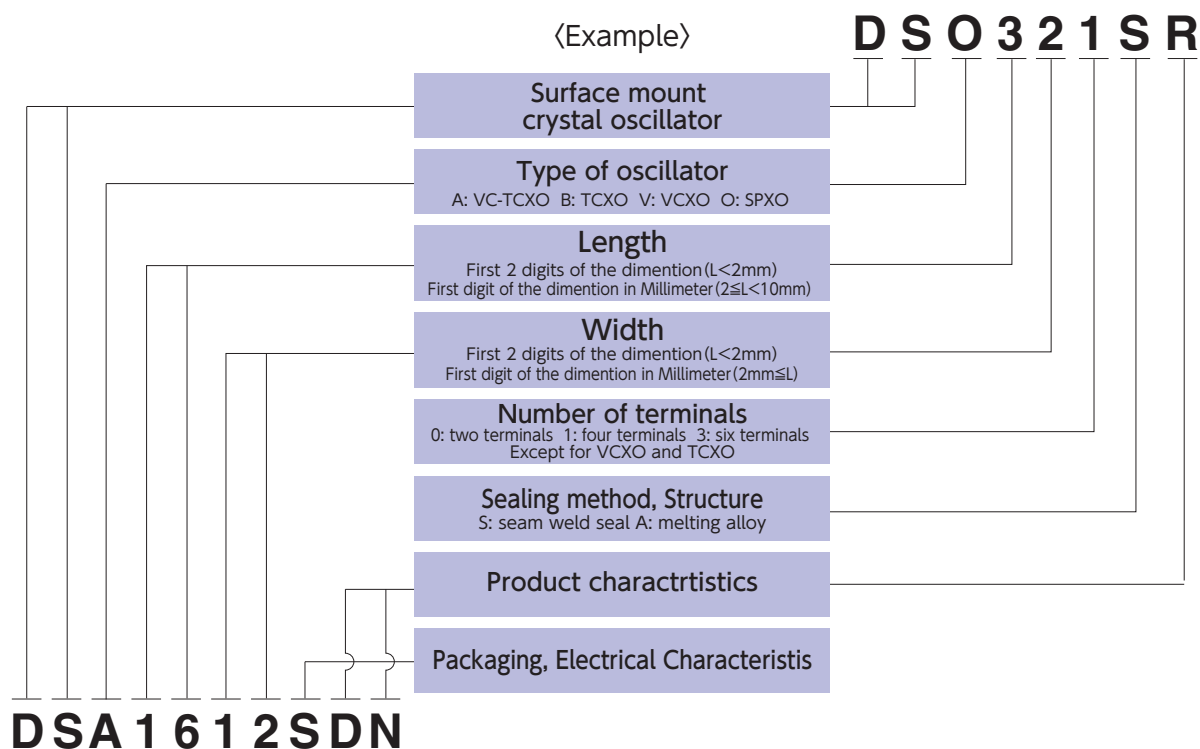
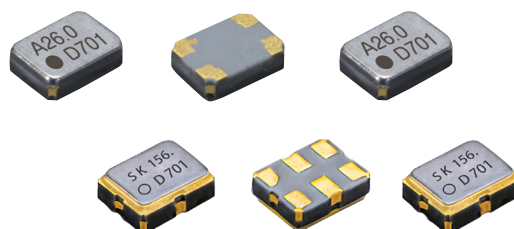

Crystal Oscillators

Description

●Simple Packaged Crystal Oscillators (SPXO)

SPXO is an oscillator for clock, which uses crystal resonance to create an electrical signal with a more precise frequency and are suitable for clock signal generators.

●Voltage Controlled Crystal Oscillators (VCXO)

These crystal oscillators have a variable-capacitance diode inserted into a SPXO oscillation loop, and enables the oscillation frequency to change by varying the voltage of the external power supply. The temperature characteristic of these oscillators are equivalent to those of the SPXO loop and takes advantage of the good attributes of crystal resonators.

●Temperature Compensated Crystal Oscillators (TCXO)

These high-precision crystal oscillators have a built-in circuit that corrects frequency variations resulting from temperature variations of the crystal resonator. It is optimal for applications where small frequency tolerance is required across a wide temperature.

●Oven Controlled Crystal Oscillator (OCXO)

OCXO is a super high-precision crystal oscillator with very small frequency variations by a built-in thermostatic bath, to maintain a constant temperature of the crystal resonator.

Available to the frequency reference, such as instruments and infrastructure base stations.

●Real Time Clock Module (RTC)

RTC is a high-precision crystal application product with built-in tuning-fork crystal oscillator, has an interrupt function and data provide function necessary for calendar clock function, such as year, month, day, hour, minute and second.

We also have a lineup of crystal oscillators (molded oscillators) in which the crystal resonators and IC are packaged in a molded package.

Terminology

Output Frequency	Nominal value of output frequency of a crystal controlled oscillator.
Frequency Tolerance (Crystal Oscillators)	The maximum permissible deviation of the oscillator frequency from a specified nominal value, when operating under specified condition.
Frequency Characteristics over Temperature (Crystal Oscillators)	Deviation from the frequency at the specified reference temperature due to operation over the specified temperature range, when other conditions remain constant.
Frequency Stability vs. Supply Voltage	Deviation from the frequency at the specified supply voltage due to operation over the specified range, when other conditions remain constant.
Frequency Stability vs. Load Variation	Deviation from the frequency at the specified load conditions due to changes in load impedance over the specified range, when other conditions remain constant.
Frequency Stability vs. Aging	The rate of output frequency change when an oscillator is operated under a specified condition and operating time.
Operating Temperature Range	Temperature range over which the crystal oscillator can be operated within allowable deviation range.
Supply Voltage	The DC input voltage necessary for oscillator operation.
Current Consumption	Operating current consumption.
Stand-by Current	The current consumption, when the oscillator stops oscillating by the control voltage applied to the control pin of an oscillator having the output control function.
Start up Time	The duration from the oscillation start until it reaches the specified output amplitude after power was applied.
Load Condition	Types or the number (capacity) of loads that can be connected to the oscillator.
Output Level	Amplitude of output waveform.
Rise Time	The time interval required for the leading edge of a waveform to change between two defined levels.
Fall Time	The time interval required for the trailing edge of a waveform to change between two defined levels.
Symmetry	The ratio between the time, in which the output voltage is above a specified level, and time in which the output voltage is below the specified level, in percent of the duration of the full signal period.
Output Disable Time	Time lag between control-signal input and oscillation output, where oscillation output is on. Specified for models with output control function.
Output Enable Time	Time lag between control-signal input and oscillation output, with oscillation output switched off (no output load). Specified for models with output control function.
3-state	The situation that the output goes to a high impedance when an oscillator stops oscillating by the standby function.
Phase Noise	The generic designation of the unwanted emission of energy around the nominal frequency generated by an oscillator.
Phase Jitter	The phenomenon when the phase of the pulse wave of the output signal of an oscillator moves back and forth in time from its ideal position. It is called jitter when the frequency fluctuations of the phase in time is over 10Hz.
Harmonics	Unwanted frequency component, which is higher than the desired output frequency of an oscillator.
Frequency Adjustment Range	The output frequency range which can be shifted by the control voltage from outside to VCXOs.
Frequency Control Voltage	The range of input voltage from outside to shift the frequency of VCXOs.

High-precision SMD VC-TCXO/TCXO

DSB1612SEB

NEW

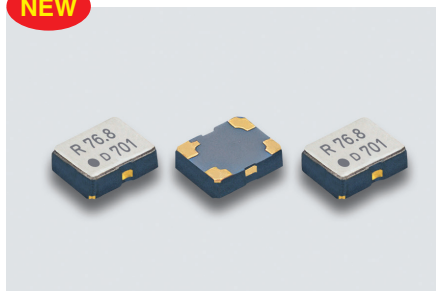

Actual size □

■ Features

- Capable of operating over a wide temperature range from -40 to $+105^{\circ}\text{C}$
- High frequencies operation
- Low voltage operation
- Clipped sine wave
- Low phase noise
- Single package structure
- AEC-Q200 Compliant



■ Applications

- Automotive WiFi, WiLAN, WiMAX, Bluetooth
- GNSS, Industrial equipment

■ Standard Specification

Item	DSB1612SEB	
Output Frequency Range	26 to 76.8MHz	
Supply Voltage Range	$+1.8$ to $+3.3\text{V}$	
Current Consumption	$+4.5\text{mA max. (f} \leq 52\text{MHz)}$ / $+5.0\text{mA max. (f} > 52\text{MHz)}$	
Stand-by Current (#1 pin "L" Level)	$+3\mu\text{A max.}$	
Output Level	$0.8\text{Vp-p min. (Clipped Sine Wave / DC-coupled)}$	
Output Load	$10\text{k}\Omega//10\text{pF}$	
Frequency Stability	$\pm 2.0 \times 10^{-6}$ max.(After 2 reflows)	
Tolerance	$\pm 2.0 \times 10^{-6}$ max.(After 2 reflows)	
vs. Temperature	$\pm 5.0 \times 10^{-6}$ max. (-40 to $+105^{\circ}\text{C}$)	$\pm 0.5 \times 10^{-6}$ max. (-40 to $+85^{\circ}\text{C}$)
vs. Supply Voltage	$\pm 0.2 \times 10^{-6}$ max. ($V_{\text{cc}} \pm 5\%$)	
vs. Load Variation	$\pm 0.2 \times 10^{-6}$ max.	
vs. Aging	$\pm 2.0 \times 10^{-6}$ max./year	
Start up Time	2.0ms max.	
Phase Noise	[$f \leq 52\text{MHz}$]	[$f > 52\text{MHz}$]
Offset 100Hz	-110dBc/Hz	-108dBc/Hz
Offset 1kHz	-130dBc/Hz	-125dBc/Hz
Offset 10kHz	-152dBc/Hz	-150dBc/Hz
Offset 100kHz	-155dBc/Hz	-155dBc/Hz
Packing Unit (1)	3000pcs./reel ($\Phi 180$)	

(1) Moisture prevention packing is unnecessary.
Moisture Sensitivity Level : Level1 (IPC/JEDEC J-STD-033)

Consult our sales representative for other specifications.

[mm]

■ Dimensions

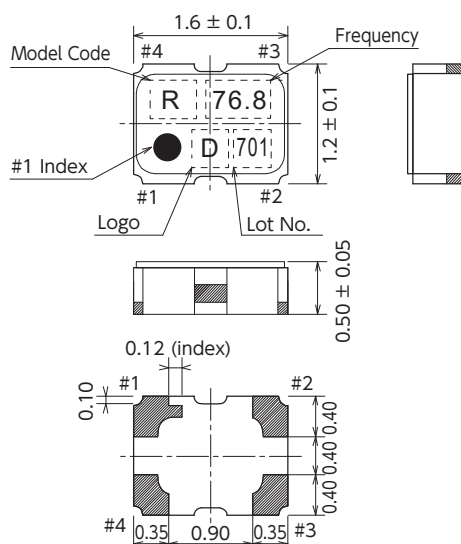

■ Recommended Land Pattern

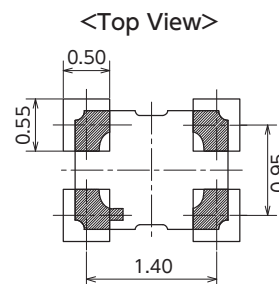

Pin Connections

Pin No.	Connection
#1	O.E. (Output Enable)
#2	GND
#3	Output
#4	Vcc

Output Enable
H Oscillation
L Stand by

High-precision SMD VC-TCXO/TCXO

DSA1612SDN/DSA211SDN/DSA221SDN/DSA321SDN, DSB1612SDN/DSB211SDN/DSB221SDN/DSB321SDN

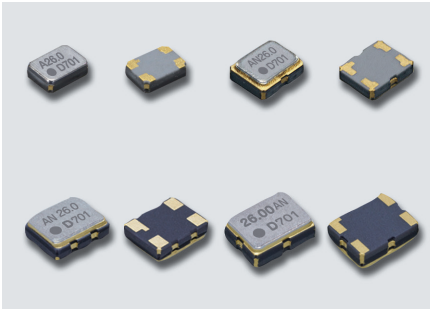

■ Features

- Low voltage operation
- Selectable between standard type and GPS/GNSS specialized type (DSB1612SDN)
- Clipped sine wave
- Low phase noise
- Single package structure

■ Applications

- Mobile phones
- GPS/GNSS and Industrial radio communications

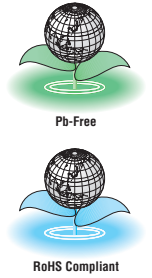

Actual size DSA1612SDN □ DSA211SDN □
DSA221SDN □ DSA321SDN □

[Type]

VC-TCXO	TCXO	Size
DSA1612SDN	DSB1612SDN	1612 size
DSA211SDN	DSB211SDN	2016 size
DSA221SDN	DSB221SDN	2520 size
DSA321SDN	DSB321SDN	3225 size

■ Standard Specification

Item	Type	VC-TCXO				TCXO			
		DSA1612SDN	DSA211SDN	DSA221SDN	DSA321SDN	DSB1612SDN	DSB211SDN	DSB221SDN	DSB321SDN
Frequency Range		9.6 to 60MHz	9.6 to 52MHz	9.6 to 52MHz		9.6 to 60MHz	9.6 to 52MHz	9.6 to 52MHz	
Standard Frequency		19.2MHz/26MHz/38.4MHz/40MHz/52MHz				16.3676MHz/16.367667MHz/16.368MHz/16.369MHz/16.8MHz/26MHz/33.6MHz			
Supply Voltage Range		+1.68 to +3.5V							
Supply Voltage (Vcc)		+1.8V/+2.6V/+2.8V/+3.0V/+3.3V							
Current Consumption		+1.5mA max. (f≤26MHz) /+2.0mA max. (26<f≤52MHz) /+2.5mA max. (f≤60MHz)							
Output Level		0.8Vp-p min. (f≤52MHz) (Clipped Sinewave/DC-coupled)							
Output Load		10kΩ//10pF							
Frequency Stability Tolerance		±1.5×10 ⁻⁶ max. (After 2 reflows)							
vs. Temperature		±1.0×10 ⁻⁶ , ±2.5×10 ⁻⁶ max./-30 to +85°C ±1.0×10 ⁻⁶ , ±2.5×10 ⁻⁶ max./-40 to +85°C (Option)				±0.5×10 ⁻⁶ , ±2.5×10 ⁻⁶ max./-30 to +85°C ±0.5×10 ⁻⁶ , ±2.5×10 ⁻⁶ max./-40 to +85°C (Option)			
vs. Supply Voltage		±0.2×10 ⁻⁶ max. (Vcc ±5%)							
vs. Load Variation		±0.2×10 ⁻⁶ max. (10kΩ//10pF±10%)							
vs. Aging		±1.0×10 ⁻⁶ max./year							
Frequency Control Control Sensitivity		±3.0×10 ⁻⁶ to ±5.0×10 ⁻⁶ /Vcont=+1.4V±1V @Vcc≥+2.6V ±3.0×10 ⁻⁶ to ±5.0×10 ⁻⁶ /Vcont=+0.9V±0.6V @Vcc=+1.8V				-			
Response Slope		Positive				-			
Start up Time		2.0ms max.							
Phase Noise		[f≤26MHz]		[26MHz<f≤40MHz]		[40MHz<f≤52MHz]			
Offset 100Hz		-115dBc/Hz		-110dBc/Hz		-105dBc/Hz			
Offset 1kHz		-130dBc/Hz		-130dBc/Hz		-125dBc/Hz			
Offset 10kHz		-150dBc/Hz		-150dBc/Hz		-145dBc/Hz			
Offset 100kHz		-155dBc/Hz		-155dBc/Hz		-150dBc/Hz			
Packing Unit (1)		DSA1612SDN/DSA211SDN/DSA221SDN, DSB1612SDN/DSB211SDN/DSB221SDN : 3000pcs./reel (φ180) DSA321SDN, DSB321SDN : 2000pcs./reel (φ180)							

(1) Moisture prevention packing is unnecessary.
Moisture Sensitivity Level : LEVEL 1 (IPC/JEDEC J-STD-033)

Consult our sales representative for other specifications.

High-precision SMD VC-TCXO/TCXO

For Mobile communications/Industrial system/GPS/GNSS

■ Dimensions

[mm]

■ DSA1612SDN/DSB1612SDN

Model Code
A: VC-TCXO (DSA1612SDN)
B: TCXO (DSB1612SDN)

Pin Connections	
Pin No.	Connection
#1	Vcont(VC-TCXO)/GND(TCXO)
#2	GND
#3	Output
#4	Vcc

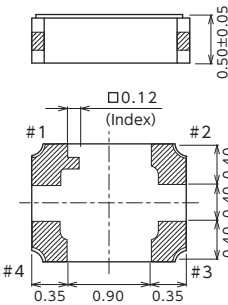
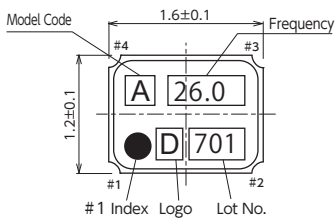

■ Recommended Land Pattern <Top View>

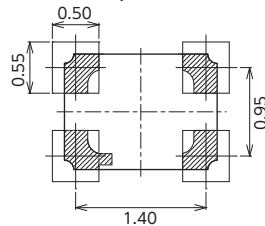

■ DSA211SDN/DSB211SDN

Model Code
AN : VC-TCXO (DSA211SDN)
BN : TCXO (DSB211SDN)

Pin Connections	
Pin No.	Connection
#1	Vcont(VC-TCXO)/GND(TCXO)
#2	GND
#3	Output
#4	Vcc

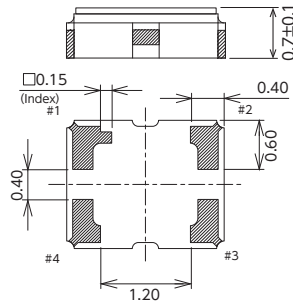
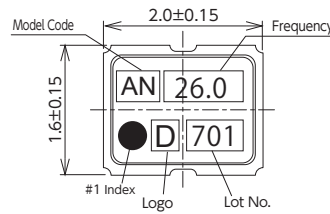

■ Recommended Land Pattern <Top View>

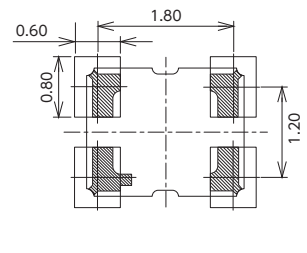

■ DSA221SDN/DSB221SDN

Model Code
AN : VC-TCXO (DSA221SDN)
BN : TCXO (DSB221SDN)

Pin Connections	
Pin No.	Connection
#1	Vcont(VC-TCXO)/GND(TCXO)
#2	GND
#3	Output
#4	Vcc

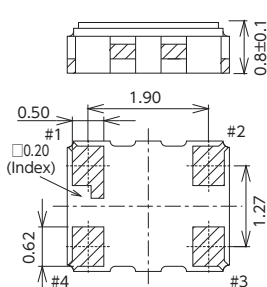
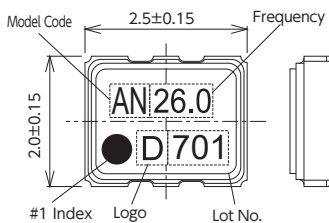

■ Recommended Land Pattern <Top View>

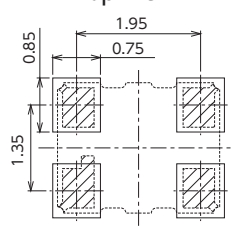

■ DSA321SDN/DSB321SDN

Model Code
AN : VC-TCXO (DSA321SDN)
BN : TCXO (DSB321SDN)

Pin Connections	
Pin No.	Connection
#1	Vcont(VC-TCXO)/GND(TCXO)
#2	GND
#3	Output
#4	Vcc

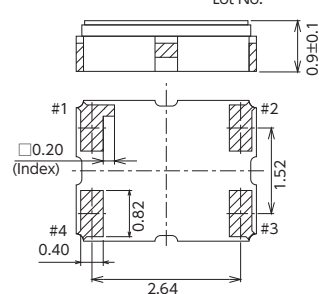
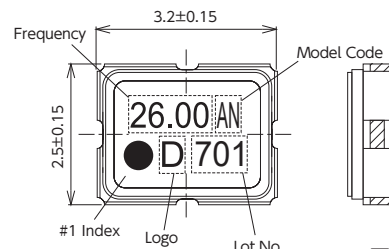

■ Recommended Land Pattern <Top View>

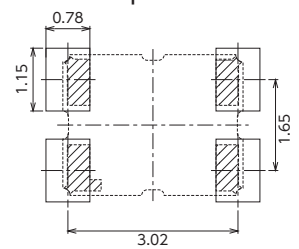

Ultra High-precision SMD VC-TCXO/TCXO

DSA535SGA/DSB535SGA/DSA535SGB for Stratum3/ Femtocell

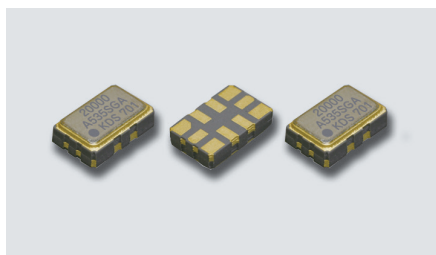

Actual size

Features

- 5032 size. 1.35mm height.
- Ultra high precision SMD (VC-) TCXO
- Clipped-sine wave or CMOS level output
- Low phase noise
- Single packaged structure

Applications

- Stratum3, 5G compatible devices, Networking, Base station



Standard Specification

Item	DSA535SGB (VC-TCXO)	DSA535SGA (VC-TCXO)	DSB535SGA (TCXO)
Output Frequency Range	10 to 52MHz		
Standard Frequency	10MHz/ 19.2MHz/ 20MHz/ 38.88MHz		
Supply Voltage (Range)	+2.3 to +3.63V		
Supply Voltage (Vcc)	+2.8V/ +3.0V/ +3.3V		
Current Consumption	+4.0mA max. (Clipped sine wave)/ +8.0mA max. (CMOS)		
Output Level	0.8Vp-p min. (Clipped sine wave/DC-coupled) '0'level 0.1×Vcc V max./'1'level 0.9×Vcc V min. (CMOS)		
Output Load	10kΩ//10pF (Clipped sine wave)/15pF (CMOS)		
Frequency Stability Tolerance	±1.5×10 ⁻⁶ max. (After 2 reflows)		
vs. Temperature	±0.10×10 ⁻⁶ max. / -40 to +85°C ±0.20×10 ⁻⁶ max. / -40 to +105°C		
vs. Temperature Characteristic Control Voltage Change	±0.1×10 ⁻⁶ max. (Frequency control sensitivity ±5×10 ⁻⁶ , Vcont=+1.5V±1.0V)	—	
vs. Hysteresis	±0.1×10 ⁻⁶ max.		
vs. Supply Voltage	±0.1×10 ⁻⁶ max. (Vcc±5%: Clipped sine wave, CMOS (f≤40MHz))/±0.2×10 ⁻⁶ max. (Vcc±5%: CMOS (40MHz<f))		
vs. Load Variation	±0.20×10 ⁻⁶ max. (10kΩ//10pF±10%/ 15pF ±10%)		
vs. Aging	±1.0×10 ⁻⁶ max./year		
Total Frequency Tolerance	±4.6×10 ⁻⁶ max. (Inclusive of variations over operating temperature, initial tolerance, supply voltage, load variation, aging)		
Frequency Control Control Sensitivity	±3.0 to ±5.0 × 10 ⁻⁶ /Vcont=+1.5±1V		—
Response Slope	Positive		—
Phase Noise Offset 100Hz	20MHz (typ.) -118dBc/Hz		20MHz (typ.) -120dBc/Hz
Offset 1kHz	-139dBc/Hz		-141dBc/Hz
Offset 10kHz	-155dBc/Hz		-155dBc/Hz
Offset 100kHz	-158dBc/Hz		-158dBc/Hz
Packing Unit (1)	1000pcs./reel (φ 180), 4000pcs./reel (φ 330)		

(1) Moisture prevention packing is unnecessary.
Moisture Sensitivity Level: LEVEL 1 (IPC/JEDEC J-STD-033)

Consult our sales representative for other specifications.

DSA535SGA/DSB535SGA/DSA535SGB (4terminals) [mm]

DSA535SGA/DSB535SGA/DSA535SGB (10 terminals) [mm]

Dimensions

Model Code
DSA535SGA→A535SGA
DSB535SGA→B535SGA
DSA535SGB→A535SGB

Pin Connections(4terminals)

Pin No.	Connection
#1	VCONT(VC-TCXO)/ GND(TCXO)
#2	GND
#3	Output
#4	Vcc

Recommended Land Pattern <Top View>

Connect to GND Bypass Capacitance
Connect to Test Circuit DC-cut Capacitance

Dimensions

Model Code
DSA535SGA→A535SGA
DSB535SGA→B535SGA
DSA535SGB→A535SGB

Pin Connections

Pin No.	Connection
#1	Vcont(VC-TCXO)/GND(TCXO)
#2	Do Not Connect
#3	ENABLE/DISABLE
#4	GND
#5	Do Not Connect
#6	Output
#7	Do Not Connect/Vcfilter(Optional)
#8	Do Not Connect
#9	Vcc
#10	GND

() : Internal connection

Recommended Land Pattern <Top View>

Connect to GND Bypass Capacitance
Connect to Test Circuit DC-cut Capacitance

SMD TCXO

DSB211SJA/DSB221SJA

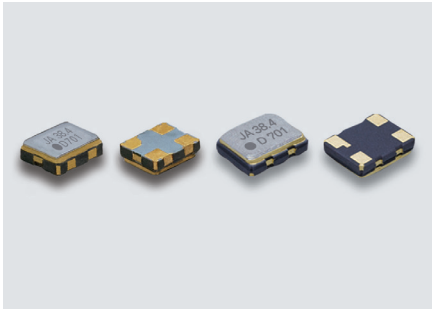

Actual size DSB211SJA □ DSB221SJA □

Features

- Capable of operating over a wide temperature range, from -40 to +105°C
- Supply voltage from +1.7 up to +3.6V
- CMOS Level Output
- Low phase noise
- Single package structure
- AEC-Q100/AEC-Q200 Compliant (DSB211SJA)



Applications

- WiLAN, WiMAX, Smart Grid, visual applications and industrial radio communications

Standard Specification

Item	Type	DSB211SJA	DSB221SJA
Frequency Range		13 to 54MHz	11 to 52MHz
Standard Frequency		19.2MHz/ 25MHz/ 26MHz/ 32MHz/ 38.4MHz/ 40MHz/ 48MHz/ 52MHz	
Supply Voltage (Vcc)		+1.8V/ +2.5V/ +2.8V/ +3.3V	
Current Consumption		5.0mA max. [No Load]	
Stand-by Current (#1 pin "L" Level)		+10μA max.	
Frequency Stability Tolerance		±1.5×10 ⁻⁶ max.(After 2 reflows)	
vs. Temperature		±2.5×10 ⁻⁶ max./ -40 to +85°C ±5.0×10 ⁻⁶ max./ -40 to +105°C ±20×10 ⁻⁶ max./ -40 to +125°C(Option)	
vs. Aging		±1.0×10 ⁻⁶ max./year	
Symmetry		45 to 55% (50% Vcc Level)	
0 Level Output Voltage		Vcc×0.1V max.	
1 Level Output Voltage		Vcc×0.9V min.	
Output Load		15pF	
Rise and Fall Time		5ns max.(10% to 90% Vcc Level)	
OE Pin 0 Level Input Voltage		Vcc×0.2V max.	
OE Pin 1 Level Input Voltage		Vcc×0.8V min.	
Start Up Time		3.0ms max.	
Output Enable Time		3.0ms max.	
Output Disable Time		150ns max.	
Start Up Time		[f≤26MHz]	[26MHz<f≤52MHz]
Offset 1kHz		-145dBc/Hz	-141dBc/Hz
Offset 100kHz		-158dBc/Hz	-157dBc/Hz
Packing Unit (1)		3000pcs./reel (φ180)	

(1) Moisture prevention packing is unnecessary.
Moisture Sensitivity Level : LEVEL 1 (IPC/JEDEC J-STD-033)

Consult our sales representative for other specifications.

DSB211SJA

[mm]

DSB221SJA

[mm]

Dimensions

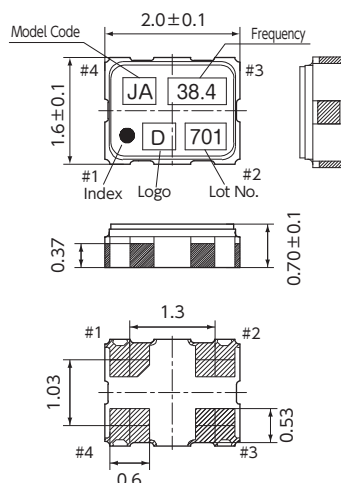

Pin Connections	
Pin No.	Connection
#1	OE (Output Enable)
#2	GND
#3	Output
#4	Vcc

Function	
#1 Input	#3 Output condition
H	Oscillation out
L	High Z

Recommended Land Pattern <Top View>

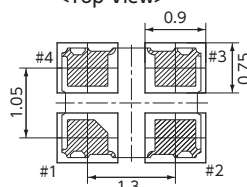

Dimensions

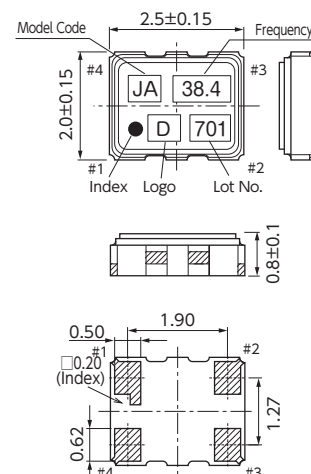

Pin Connections	
Pin No.	Connection
#1	OE (Output Enable)
#2	GND
#3	Output
#4	Vcc

Function	
#1 Input	#3 Output condition
H	Oscillation out
L	High Z

Recommended Land Pattern <Top View>

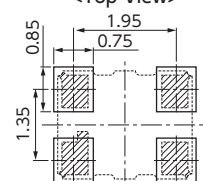

SMD TCXO

DSK1612ATD

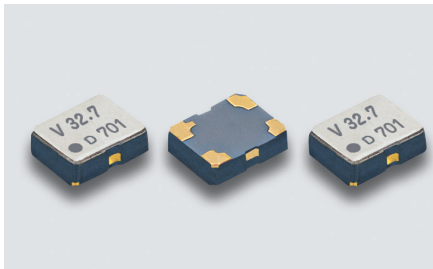

Actual size

■ Features

- Digital temperature compensated type
- High precision : $\pm 5.0 \times 10^{-6}$ (-40 to +85°C)
- Low current consumption
- CMOS level output

■ Applications

- High precision clock source
- High precision clock source for RTC



■ Standard Specification

Item	Legend	Spec.				Condition
		min.	typ.	max.	Unit	
Output Frequency	f_0	—	32.768	—	kHz	
Supply Voltage Range	V_{CC}	+1.5	—	3.63	V	Temperature Compensated Operating
Frequency Tolerance	f_{tol}	-5.0	—	+5.0	$\times 10^{-6}$	$V_{CC}=+1.8V$ or $+3.3V$, $T_A=-40$ to $+85^\circ C$ (Standard operating temperature range, Referenced to 32.768kHz)
Current Consumption	I_{CC1}	—	0.90	1.90	μA	$V_{CC}=+1.8V$, $T_A=-40$ to $+85^\circ C$, at No Load (1)
		—	1.23	2.60		$V_{CC}=+3.3V$, $T_A=-40$ to $+85^\circ C$, at No Load (1)
	I_{CC2}	—	1.26	2.43		$V_{CC}=+1.8V$, $T_A=-40$ to $+85^\circ C$, at No Load Temperature Compensation Interval: 0.5s (standard specification) (2)
		—	1.59	3.12		$V_{CC}=+3.3V$, $T_A=-40$ to $+85^\circ C$, at No Load Temperature Compensation Interval: 0.5s (standard specification) (2)
Symmetry	SYM	40	50	60	%	at 50% V_{CC}
0 Level Output Voltage	V_{OL}	—	—	$V_{CC} \times 0.1$	V	
1 Level Output Voltage	V_{OH}	$V_{CC} \times 0.9$	—	—	V	
Rise and Fall Time	t_r, t_f	—	—	40	ns	10 to 90% V_{CC} Level
Load Condition	L_{CMOS}	—	—	15	pF	
Start Up Time	T_{start}	—	—	0.5	s	
Packing Unit (3)						3000pcs./reel ($\phi 180$)

- (1) I_{CC1} is the current value when the temperature compensation circuit is not operating. Consult our sales representative for other specifications.
 (2) I_{CC2} is the average current value when the temperature compensation circuit is operating and non-operating.
 (3) Moisture prevention packing is unnecessary. Moisture Sensitivity Level : Level1 (IPC/JEDEC J-STD-033)

[mm]

■ Dimensions

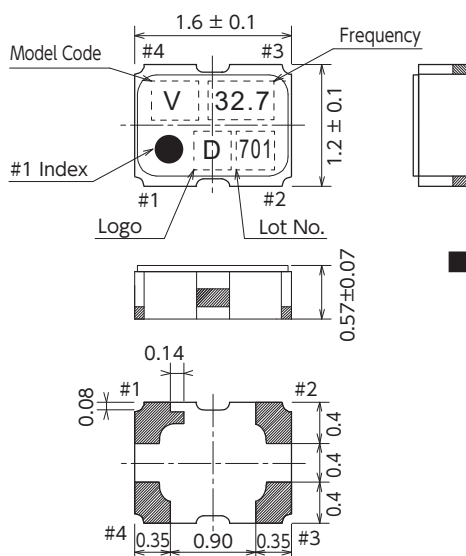

Pin No.	Connection
#1	GND
#2	Output
#3	V_{CC}
#4	GND

■ Recommended Land Pattern

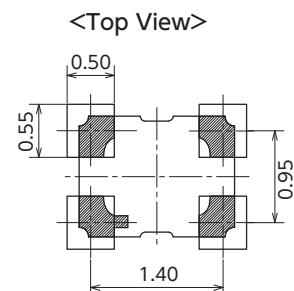

■ Current profile

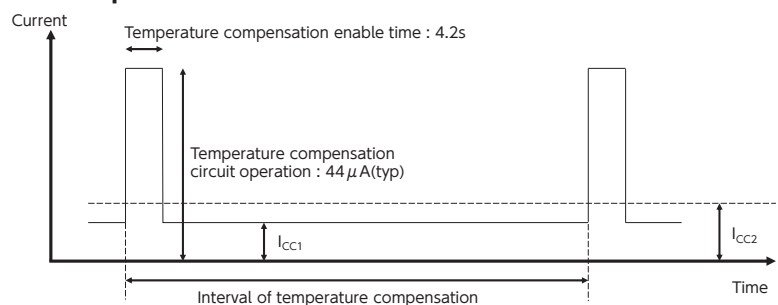

$$I_{CC2}(\text{typ}) = 0.90 \mu A \times (0.5s - 4.2ms) / 0.5s + 44 \mu A \times 4.2ms / 0.5s = 1.26 \quad (V_{CC} = 1.8V)$$

$$I_{CC2}(\text{typ}) = 1.23 \mu A \times (0.5s - 4.2ms) / 0.5s + 44 \mu A \times 4.2ms / 0.5s = 1.59 \quad (V_{CC} = 3.3V)$$

SMD Real Time Clock Module

DD3225TS

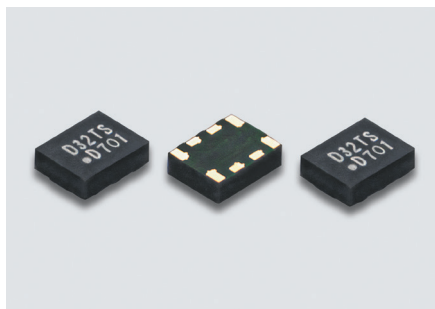

Actual size

Features

- Digital temperature compensated type
- High precision : $\pm 5.0 \times 10^{-6}$ (-40 to +85°C), $\pm 7.0 \times 10^{-6}$ (-40 to +105°C)
- Low current consumption
- Low voltage operation : +1.5 to +5.5V (Temperature Compensated Operating), +1.3 to +5.5V (Clock Timing Operating)
- I²C-BUS serial interface : 400kHz fast-mode compatible
- Clock function : hour·minute·second, Calendar function with auto leap year adjustment : year·month·day·day of week
- Alarm interrupt function : day·day of week·hour·minute
- Fixed-cycle timer interrupt function : 244 μ s to 255min
- Time update interrupt function : minute·second
- Clock output function : 32.768kHz, 1024Hz, 32Hz, 1Hz
- Supply voltage detection function :
 - +1.5V temperature compensation operating voltage detection
 - +1.3V supply voltage under voltage detection
- CMOS Level Output
- AEC-Q100/AEC-Q200 compliant
- * "I²C-BUS" is a trademark of NXP semiconductors.



Applications

- High precision clock source
- Car navigation, Smart meter, Data logger

Standard Specification

Item	Legend	Spec.				Condition
		min.	typ.	max.	unit	
Output Frequency	f _o	—	32.768	—	kHz	
Supply Voltage Range	V _{cc}	+1.3	—	+5.5	V	(Clock Timing Operating)
	V _{tem}	+1.5	—	+5.5		(Temperature Compensated Operating)
	V _{int}	+1.5	—	+5.5		(Interface Operation) I ² C-BUS
Frequency Tolerance	f _{tol}	— 5	—	+5	$\times 10^{-6}$	— 40 to +85°C
		— 7	—	+7		— 40 to +105°C
Current Consumption	I _{cc1}	—	0.30	2.10	μ A	V _{cc} = +3.0V Temperature Compensation Interval:30s, SCL = SDA = INTN = V _{cc} ,OE = GND (Output Off)
		—	0.42	2.90		V _{cc} = +5.0V
	I _{cc2}	—	0.90	2.80		V _{cc} = +3.0V Temperature Compensation Interval:30s, SCL = SDA = INTN = OE = V _{cc}
		—	1.30	4.00		V _{cc} = +5.0V (Output On), No Load
Load Condition	L _{CMOS}	—	—	15	pF	
Symmetry	SYM	40	—	60	%	50%V _{cc}
1 level Output Voltage	V _{OH}	0.8xV _{cc}	—	—	V	I _{OH} = — 1mA
0 level Output Voltage	V _{OL}	—	—	0.2xV _{cc}	V	I _{OL} = 1mA
Rise / Fall Time	Tr/Tf	—	—	100	ns	20 to 80%V _{cc}
OE Pin 1 level Input Voltage	V _{IH}	0.8xV _{cc}	—	V _{cc}	V	
OE Pin 0 level Input Voltage	V _{IL}	0	—	0.2xV _{cc}	V	
Start Up Time	T _{start}	—	—	1	s	T _a = +25°C, V _{cc} = +1.3V
Packing Unit (1)						2000pcs./reel (ϕ 180)

(1) Moisture prevention packing
Moisture sensitivity level : Level 2 (IPC/JEDEC J-STD-033)

Consult our sales representative for other specifications.

[mm]

Dimensions

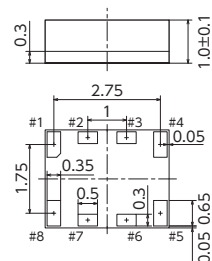
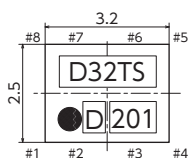

Function	
#1 Input	#5 Output Condition
H	Oscillation out
L	High Z

Marking	
(1) Type	D32TS
(2) Logo	D
(3) Date code	Year(1digit) + Week(2digits) e.g.2022/1/1 → 201

Recommended Land Pattern

<Top View>

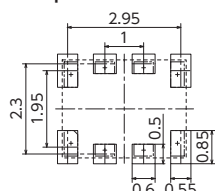

Pin Function			
No.	Name	I/O	Description
#1	OE	I	Output control enable input (L:High impedance,H:Clock output)
#2	INTN	0	1Hz signal, alarm interrupt signal, fixed-cycle timer interrupt signal, and time update interrupt signal, Nch open-drain output.
#3	N.C.	-	Do not connect
#4	GND	-	Ground connection.
#5	Output	0	Clock output connection.
#6	SCL	I	I ² C-BUS serial interface clock input connection.
#7	SDA	I/O	I ² C-BUS serial interface data input/output connection.
#8	V _{cc}	-	Supply Voltage

SMD Real Time Clock Oscillator

DD3225TR

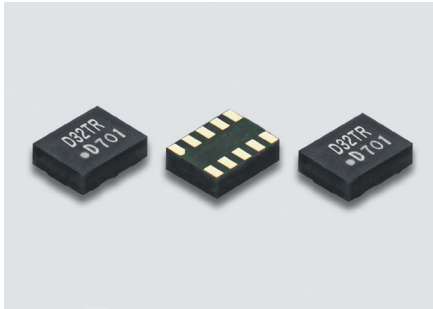

Actual size

■ Features

- Precision : $\pm 11.5 \times 10^{-6}$ (30 seconds per month), $\pm 23.0 \times 10^{-6}$ (60 seconds per month)
- Low current consumption
- Low voltage operation : +1.5 to +5.5V, +1.3 to +5.5V (Clock Timing Operating)
- I²C-BUS serial interface : 400kHz fast-mode compatible
- Clock function : hour·minute·second, Calendar function with auto leap year adjustment : year·month·day·day of week
- Alarm interrupt function : day·day of week
- Fixed-cycle timer interrupt function : 244 μ s to 255min
- Time update interrupt function : minute·second
- Clock output function : 32.768kHz, 1024Hz, 32Hz, 1Hz
- CMOS Level Output
- * "I²C-BUS" is a trademark of NXP semiconductors.



■ Applications

- Calendar, Timer, Alarm, Standard for watches
- Remote control with calendar, Data logger, Wireless sensor, Amusement device

■ Standard Specification

Item	Legend	Spec.				Condition
		min.	typ.	max.	unit	
Output Frequency	f _o	—	32.768	—	kHz	
Supply Voltage Range	V _{cc}	+1.3	—	+5.5	V	(Clock Timing Operating)
	V _{int}	+1.5	—	+5.5		(Interface Operation) I ² C-BUS
Frequency Tolerance	f _{tol}	- 11.5	—	+11.5	$\times 10^{-6}$	T _a = 25°C, V _{cc} = +3.0V (30 seconds per month)
		- 23	—	+23		T _a = 25°C, V _{cc} = +3.0V (60 seconds per month)
Operating temperature range	T _a	- 40	—	+85	°C	
Current Consumption	I _{cc1}	—	0.29	2.10	μ A	V _{cc} = +3.0V SCL = SDA = INTN = V _{cc} , OE = GND (Output Off)
		—	0.41	2.90		V _{cc} = +5.0V
	I _{cc2}	—	0.89	2.80	μ A	V _{cc} = +3.0V SCL = SDA = INTN = OE = V _{cc} (Output On), No Load
		—	1.29	4.00		V _{cc} = +5.0V
Load Condition	L _{CMOS}	—	—	15	pF	
Symmetry	SYM	40	—	60	%	50%V _{cc}
1 level Output Voltage	V _{OH}	0.8xV _{cc}	—	—	V	I _{OH} = - 1mA
0 level Output Voltage	V _{OL}	—	—	0.2xV _{cc}	V	I _{OL} = 1mA
Rise / Fall Time	Tr/Tf	—	—	100	ns	20 to 80%V _{cc}
OE Pin 1 level Input Voltage	V _{IH}	0.8xV _{cc}	—	V _{cc}	V	
OE Pin 0 level Input Voltage	V _{IL}	0	—	0.2xV _{cc}	V	
Start Up Time	T _{start}	—	—	1	s	T _a = +25°C, V _{cc} = +1.3V
Packing Unit (1)						2000pcs./reel (ϕ 180)

(1) Moisture prevention packing
Moisture sensitivity level : Level 2 (IPC/JEDEC J-STD-033)

Consult our sales representative for other specifications.

[mm]

■ Dimensions

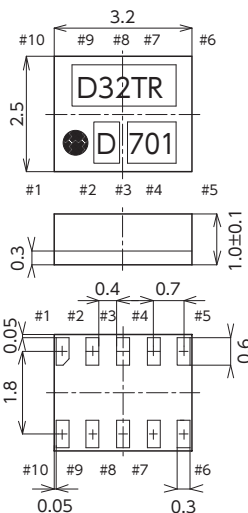

Function	
#2 Input	#4 Output Condition
H	Oscillation out
L	High Z

Marking	
(1) Type	D32TR
(2) Logo	D
(3) Date code	Year(1digit) + Week(2digits) e.g.2022/1/1 → 201

■ Recommended Land Pattern

<Top View>

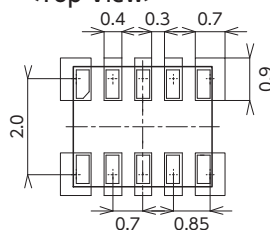

Pin Function

No.	Name	I/O	Function
#1	V _{cc}	-	Supply Voltage
#2	OE	I	Output control enable input (L:High impedance,H:Clock output)
#3	N.C.	-	Do not connect
#4	Output	O	Clock output connection
#5	SCL	I	I ² C-BUS serial interface clock input connection.
#6	EVENT	I	Trigger input for Time stamp request. Internal pull-up resistor can be selected. Input polarity can be selected.
#7	SDA	I/O	I ² C-BUS serial interface data input/output connection.
#8	N.C.	-	
#9	GND	-	Ground connection.
#10	INTN	O	1Hz signal, alarm interrupt signal, fixed-cycle timer interrupt signal, and time update interrupt signal, Nch open-drain output.

SMD Low Phase Noise Crystal Oscillators

DSO221SH/DSO321SH

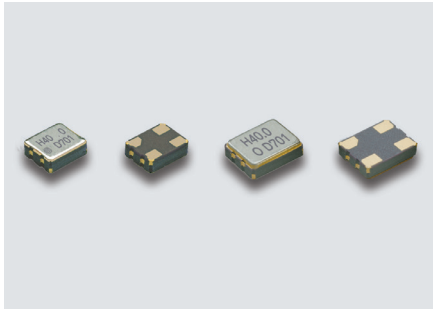

Actual size DSO221SH DSO321SH

■ Features

- Supply Voltage : 1.8V/2.5V/2.8V/3.0V/3.3V
- Low phase noise : Offset 1kHz -145 dBc/Hz(Typ.)
Offset 100kHz -158 dBc/Hz(Typ.)
- Low profile : 0.815mm(DSO221SH), 1.1mm(DSO321SH)
- CMOS Level Output
- 3-state function

■ Applications

- WiLAN, WiMAX, Bluetooth
- DVC, HDTV, Blu-ray
- PC, gaming equipment, audio equipment



[Function Code]

DSO****H	A	A
A : 3.3V	A : ±100×10 ⁻⁶	
M : 3.0V	B : ±50×10 ⁻⁶	
B : 2.8V	C : ±30×10 ⁻⁶	
C : 2.5V	D : ±25×10 ⁻⁶	
D : 1.8V	E : ±20×10 ⁻⁶	

[Type]	DSO221SH	2520 size
	DSO321SH	3225 size

When requesting the product, please select the model and function code of your request.

■ Standard Specification

Item	Function Code		Output Frequency Range (MHz)	Legend	Spec.				Condition
	Supply Voltage	Frequency tolerance			min.	typ.	max.	Unit	
Supply Voltage	A	*	3.5 ≤ f ₀ ≤ 52	V _{CC}	+3.0	+3.3	+3.6	V	
	M				+2.7	+3.0	+3.3		
	B				+2.6	+2.8	+3.0		
	C				+2.25	+2.5	+2.75		
	D				+1.6	+1.8	+2.0		
Frequency Tolerance (Includes frequency tolerance at room temperature.)	*	A	3.5 ≤ f ₀ ≤ 52	f _{tol}	-100	-	+100	×10 ⁻⁶	-40 to +85°C -10 to +70°C (Standard Operating Temperature Range)
		B			-50	-	+50		
		C			-30	-	+30		
		D			-25	-	+25		
		E			-20	-	+20		
Current Consumption	A,M	*	3.5 ≤ f ₀ ≤ 52	I _{CC}	-	-	4.2	mA	No Load
	B	*			-	-	2.3		
	C	*			-	-	-		
	D	*			-	-	-		
Stand-by Current (#1 pin "L" Level)	*	*	*	I _{std}	-	-	10	μA	
Load Condition	*	*	*	L _{CMOS}	-	-	15	pF	
Symmetry	A,M,B,C	*	*	SYM	45	50	55	%	at 50% V _{CC}
	D				40	50	60		
0 Level Output Voltage	*	*	*	V _{OL}	-	-	V _{CC} ×0.1	V	
1 Level Output Voltage	*	*	*	V _{OH}	V _{CC} ×0.9	-	-		
Rise and Fall Time	A,M,B	*	*	tr, tf	-	-	4.0	ns	10 to 90% V _{CC} Level
	C,D				-	-	6.5		
OE Pin 0 Level Input Voltage	*	*	*	V _{IL}	-	-	V _{CC} ×0.2	V	
OE Pin 1 Level Input Voltage	*	*	*	V _{IH}	V _{CC} ×0.8	-	-		
Output Disable Time	*	*	*	t _{PLZ}	-	-	100	ns	
Output Enable Time	*	*	*	t _{PZL}	-	-	2.0	ms	
Phase Noise	*	*	*	-	-	-140	-	dBc/Hz	Offset 1kHz Offset 100kHz
					-	-153	-		
Period Jitter (1)	*	*	*	t _{RMS}	-	2.4	-	ps	σ
Total Jitter (1)	*	*	*	tp-p	-	23	-	ps	Peak to peak
Phase Jitter	*	*	40 ≤ f ₀ ≤ 52	tpj	-	34	-	ps	t _{DJ} +n×t _{RJ} n=14.1 (BER=1×10 ⁻¹⁵) (2)
			10 ≤ f ₀ < 40		-	-	1		f ₀ offset: 12kHz to 20MHz f ₀ offset: 12kHz to 5MHz
Packing Unit (3)	2000pcs./reel (φ180)								

- (1) Measured WAVECREST DTS-2075
- (2) t_{DJ}: Deterministic jitter t_{RJ}: Random jitter
- (3) Moisture prevention packing is unnecessary.
Moisture Sensitivity Level: Level 1 (IPC/JEDEC J-STD-033)

Consult our sales representative for other specifications.

■ DSO221SH

[mm] ■ DSO321SH

[mm]

■ Dimensions

Model Code: H40.0 D701

Pin Connections:
#1 OE (Output Enable)
#2 GND
#3 Output
#4 V_{CC}

Function:
#1 Input #3 Output condition
H Oscillation out
Open Oscillation out
L High Z

■ Recommended Land Pattern <Top View>

■ Dimensions

Model Code: H40.0 D701

Pin Connections:
#1 OE (Output Enable)
#2 GND
#3 Output
#4 V_{CC}

Function:
#1 Input #3 Output condition
H Oscillation out
Open Oscillation out
L High Z

■ Recommended Land Pattern <Top View>

SMD Crystal Oscillators

DSO221SHH

NEW



Actual size

Features

- Supply Voltage: 1.8V/2.5V/2.8V/3.3V
- Low phase noise : Offset 1kHz -146dBc/Hz(typ.)
: Offset 100kHz -164dBc/Hz(typ.)
- Available frequency range: 2.0 to 54MHz
- Low profile : 0.8 mm
- CMOS Level Output
- 3-state function

Applications

- WiLAN, WiMAX, Bluetooth
- Visual applications
- PC, gaming equipment, audio equipment

[Function Code]

DSO221SHH A A

A : 3.3V
B : 2.8V
C : 2.5V
D : 1.8V

A : $\pm 100 \times 10^{-6}$
B : $\pm 50 \times 10^{-6}$
C : $\pm 30 \times 10^{-6}$



When requesting the product, please select the model and function code of your request.

Standard Specification

Item	Function Code		Output Frequency Range (MHz)	Legend	Spec.				Condition	
	Supply Voltage	Frequency tolerance			min.	typ.	max.	Unit		
Supply Voltage	A	*	2.0≤f _o ≤54	V _{cc}	+3.0	+3.3	+3.6	V		
	B				+2.6	+2.8	+3.0			
	C				+2.25	+2.5	+2.75			
	D				+1.62	+1.8	+2.0			
Frequency Tolerance (Includes frequency tolerance at room temperature.)	*	A	*	f _{tol}	-100	-	+100	×10 ⁻⁶	-40 to +85°C	-10 to +70°C (Standard Operating Temperature Range)
		B			-50	-	+50			
		C			-30	-	+30			
Current Consumption	A	*	2.0≤f _o ≤54	I _{cc}	-	-	4.2	mA	No Load	
	B				-	-	2.3			
	C				-	-	2.3			
	D				-	-	2.3			
Stand-by Current (#1 pin "L" Level)	*	*	*	I _{std}	-	-	10	μA		
Symmetry	*	*	*	SYM	40	50	60	%	50% V _{cc} Level	
0 Level Output Voltage	*	*	*	V _{OL}	-	-	V _{cc} ×0.1	V		
1 Level Output Voltage	*	*	*	V _{OH}	V _{cc} ×0.9	-	-	V		
Rise and Fall Time	A, B, C	*	*	tr, tf	-	-	4	ns	10 to 90% V _{cc} Level	
	D				-	-	6.5			
Load Condition	*	*	*	L _{CMOS}	-	-	15	pF		
OE Pin 0 Level Input Voltage	*	*	*	V _L	-	-	V _{cc} ×0.2	V		
OE Pin 1 Level Input Voltage	*	*	*	V _H	V _{cc} ×0.8	-	-	V		
Output Disable Time	*	*	*	t _{PLZ}	-	-	100	ns		
Output Enable Time	*	*	*	t _{PZL}	-	-	2	ms		
Phase Noise	*	*	*	-	-	-146	-	dBc/Hz	Offset 1kHz	
					-	-164	-		Offset 100kHz	
Period Jitter (1)	*	*	*	t _{RMS}	-	2.4	-	ps	σ	
				tp-p	-	23	-		Peak to peak	
Total Jitter (1)	*	*	*	t _{TL}	-	34	-	ps	t _{DJ} +n×t _{RJ} n=14.1(BER=1×10 ⁻¹²) (2)	
Phase Jitter	*	*	40≤f _o ≤54	tpj	-	-	1	ps	f _o offset:12kHz to 20MHz	
			10≤f _o <40						f _o offset:12kHz to 5MHz	
Packing Unit (3)					3000pcs./reel (φ180)					

(1) Measured WAVECREST DTS-2075

Consult our sales representative for other specifications.

(2) t_{DJ} : Deterministic jitter t_{RJ} : Random jitter

(3) Moisture prevention packing is unnecessary.
Moisture Sensitivity Level: LEVEL 1 (IPC/JEDEC J-STD-033)

[mm]

Dimensions

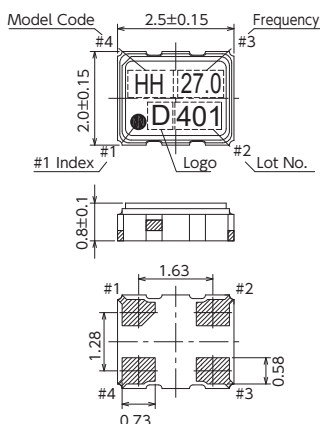

Pin Connections

Pin No.	Connection
#1	OE(Output Enable)
#2	GND
#3	Output
#4	V _{cc}

Function	#3 Output condition
H	Oscillation out
Open	Oscillation out
L	High Z

Recommended Land Pattern

<Top View>

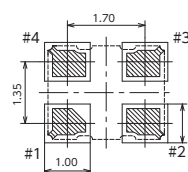

SMD Crystal Oscillators

DSO321SHH

NEW

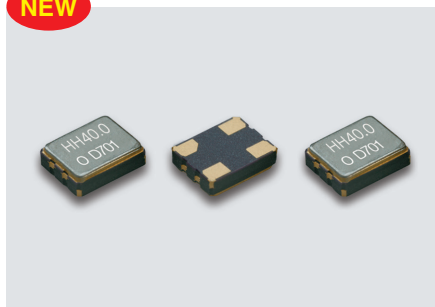

Actual size

Features

- Supply Voltage: 1.8V/2.5V/2.8V/3.3V
- Ultra low phase noise : Offset 1kHz -160dBc/Hz(typ.)
: Offset 100kHz -172dBc/Hz(typ.)
- Available frequency range: 20 to 50MHz
- Low profile : 1.1 mm
- CMOS Level Output
- 3-state function

Applications

- High quality audio equipment, Communication equipment and visual applications

[Function Code]

DSO321SHH A A

A : 3.3V	A : $\pm 100 \times 10^{-6}$
B : 2.8V	B : $\pm 50 \times 10^{-6}$
C : 2.5V	C : $\pm 30 \times 10^{-6}$
D : 1.8V	D : $\pm 25 \times 10^{-6}$

When requesting the product, please select the model and function code of your request.

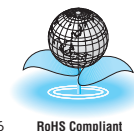

Standard Specification

Item	Function Code		Output Frequency Range (MHz)	Legend	Spec.				Condition	
	Supply Voltage	Frequency tolerance			min.	typ.	max.	Unit		
Supply Voltage	A	*	$20 \leq f_0 \leq 50$	Vcc	+3.0	+3.3	+3.6	V		
	B				+2.6	+2.8	+3.0			
	C				+2.25	+2.5	+2.75			
	D				+1.62	+1.8	+2.0			
Frequency Tolerance (Includes frequency tolerance at room temperature.)	*	A	*	f_tol	-100	-	+100	$\times 10^{-6}$	-40 to +85°C	-10 to +70°C (Standard Operating Temperature Range)
		B			-50	-	+50			
		C			-30	-	+30			
		D			-25	-	+25			
Current Consumption	A	*	$20 \leq f_0 \leq 50$	Icc	-	-	7.7	mA	No Load	
	B				-	-	5.5			
	C				-	-	4.8			
	D				-	-	2.9			
Stand-by Current (#1 pin "L" Level)	A	*	$20 \leq f_0 \leq 50$	I_std	-	-	35	μA		
	B				-	-	32			
	C				-	-	30			
	D				-	-	25			
Symmetry	*	*	*	SYM	45	50	55	%	50% Vcc Level	
0 Level Output Voltage	*	*	*	V _{OL}	-	-	Vcc×0.1	V		
1 Level Output Voltage	*	*	*	V _{OH}	Vcc×0.9	-	-	V		
Rise and Fall Time	A	*	*	tr, tf	-	-	2.1	ns	10 to 90% Vcc Level	
	B				-	-	2.5			
	C				-	-	2.7			
	D				-	-	4.7			
Load Condition	*	*	*	L _{CMOS}	-	-	15	pF		
OE Pin 0 Level Input Voltage	*	*	*	V _{IL}	-	-	Vcc×0.3	V		
OE Pin 1 Level Input Voltage	*	*	*	V _{IH}	Vcc×0.7	-	-	V		
Output Disable Time	*	*	*	t _{PLZ}	-	-	10	μs		
Output Enable Time	*	*	*	t _{PZL}	-	-	1	ms		
Phase Noise	A	*	$20 \leq f_0 \leq 50$	-	-	-160	-	dBc/Hz	Offset 1kHz	
	D				-	-158	-			
	A				-	-172	-		Offset 100kHz	
	D				-	-166	-			
Packing Unit (1)	DSO321SHH: 2000pcs./reel (ϕ 180)									

(1) Moisture prevention packing is unnecessary.
Moisture Sensitivity Level : Level1 (IPC/JEDEC J-STD-033)

Consult our sales representative for other specifications.

[mm]

Dimensions

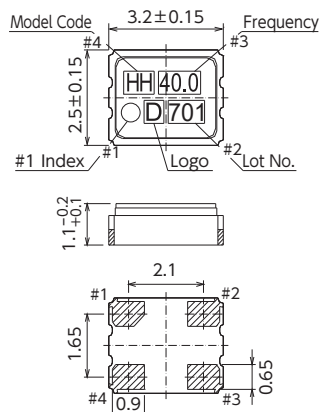

Pin Connections	
Pin No.	Connection
#1	OE (Output Enable)
#2	GND
#3	Output
#4	Vcc

Function	
#1 Input	#3 Output condition
H	Oscillation out
Open	Oscillation out
L	High Z

Recommended Land Pattern

<Top View>

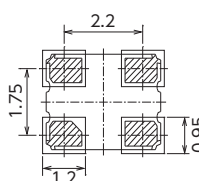

SMD Crystal Oscillators

DSO1612AR

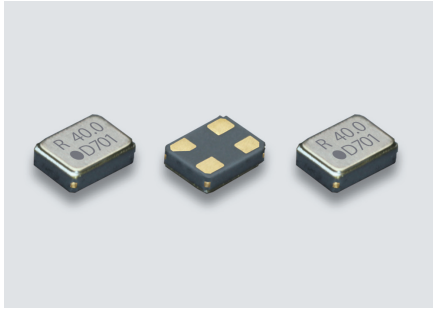

Actual size □

Features

- 1612 size, 0.5 mm height. Ultra miniature and lightweight SMD SPXO
- 3-state function
- AEC-Q200 Compliant (Option: Equivalent to AEC-Q100)
- Supply Voltage : 1.8V/2.5V/2.8V/3.0V/3.3V
- Available frequency range : 0.584375 to 80MHz
- Available up to 80MHz by using AT cut fundamental resonator. Low jitter provides for high performance.
- CMOS Level Output



Applications

- PC, DSC, DVD, DVC, HDD
- Smartphone, WiLAN, WiMAX, Bluetooth
- Gaming equipment
- Automotive multimedia device
- Wearable devices

[Function Code]

DSO1612AR

Supply Voltage	Frequency Tolerance
A : 3.3V	A : ±100×10 ⁻⁶
M : 3.0V	B : ±50×10 ⁻⁶
B : 2.8V	C : ±30×10 ⁻⁶
C : 2.5V	D : ±25×10 ⁻⁶
D : 1.8V	E : ±20×10 ⁻⁶

When requesting the product, please select the model and function code of your request.

Standard Specification

Item	Function Code		Output Frequency Range (MHz)	Legend	Spec.			Unit	Condition	
	Supply Voltage	Frequency tolerance			min.	typ.	max.			
Supply Voltage	A	*	0.584375 ≤ fo ≤ 80	Vcc	+3.0	+3.3	+3.6	V		
	M				+2.7	+3.0	+3.3			
	B				+2.6	+2.8	+3.0			
	C				+2.25	+2.5	+2.75			
	D				+1.6	+1.8	+2.0			
Frequency Tolerance (includes frequency tolerance at room temperature)	*	A	0.584375 ≤ fo ≤ 80	f_tol	-100	-	+100	× 10 ⁻⁶	-40 to +85°C	-10 to +70 (Standard Operating Temperature Range)
		B			-50	-	+50			
		C			-30	-	+30			
		D			-25	-	+25			
		E			-20	-	+20			
Current Consumption	A,M	*	0.584375 ≤ fo < 40	Icc	-	-	3.0	mA	No Load	
			40 ≤ fo ≤ 80		-	-	4.2			
	0.584375 ≤ fo < 40		-		-	2.4				
	40 ≤ fo ≤ 80		-		-	3.7				
	0.584375 ≤ fo < 40		-		-	2.0				
	40 ≤ fo ≤ 80		-		-	3.4				
	0.584375 ≤ fo < 40		-		-	1.7				
40 ≤ fo ≤ 80	-	-	2.7							
Stand-by Current (#1 pin "L" Level)	*	*	*	I_std	-	-	10	μA	-40 to +85°C	
Load Condition	*	*	0.584375 ≤ fo ≤ 80	L_CMOS	-	-	15	pF		
Symmetry	*	*	0.584375 ≤ fo ≤ 80	SYM	45	50	55	%	at 50% Vcc	
0 Level Output Voltage	*	*	*	V_OL	-	-	Vcc × 0.1	V		
1 Level Output Voltage	*	*	*	V_OH	Vcc × 0.9	-	-	V		
Rise and Fall Time	A,M,B,C	*	0.584375 ≤ fo ≤ 80	tr, tf	-	-	3.0	ns	10 to 90% Vcc Level	
OE Pin 0 Level Input Voltage	*	*	*	V_IL	-	-	Vcc × 0.2	V		
OE Pin 1 Level Input Voltage	*	*	*	V_IH	Vcc × 0.8	-	-	V		
Output Disable Time	*	*	*	tPZL	-	-	200	ns		
Output Enable Time	*	*	*	tPZL	-	-	2	ms		
Period Jitter (1)	*	*	*	tRMS	-	2.2	-	ps	σ	
Total Jitter (1)	*	*	*	tp-p	-	20	-	ps	Peak to peak	
Phase Jitter	*	*	40 ≤ fo ≤ 80	tpj	-	-	1	ps	tDJ+n×trJ n=14.1 (BER=1×10 ⁻¹²) (2) fo offset: 12kHz to 20MHz fo offset: 12kHz to 5MHz	
			10 ≤ fo < 40		-	-	-			
Packing Unit (3)	3000pcs./reel (φ180)									

(1) Measured WAVECREST DTS-2075

Consult our sales representative for other specifications.

(2) tDJ : Deterministic jitter trJ : Random jitter

(3) Moisture prevention packing is unnecessary. Moisture Sensitivity Level : Level 1 (IPC/JEDEC J-STD-033)

[mm]

Dimensions

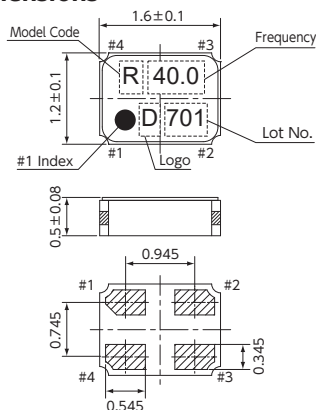

Recommended Land Pattern

<Top View>

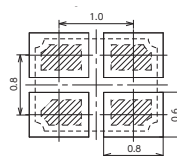

SMD Crystal Oscillators

DSO211SXF/DSO221SXF

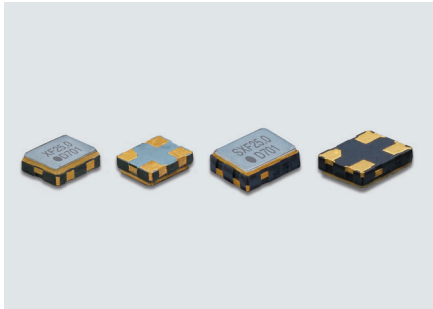

Actual size DSO211SXF □ DSO221SXF □

Features

- Supply Voltage: 1.8V/2.5V/2.8V/3.3V
- Available frequency range: 1 to 125MHz
- Low profile: 0.7mm (DSO211SXF), 0.8mm (DSO221SXF)
- CMOS Level Output
- Capable of operating over a wide temperature range, from -40 to 125°C.
- 3-state function

Applications

- Audio equipment, communication equipment, visual equipment, FA equipment, PC, gaming equipment and WiLAN



[Function Code]

DSO***SXF A Z

- | | |
|----------|---------------------------|
| A : 3.3V | A : ±100×10 ⁻⁶ |
| B : 2.8V | Z : ±80×10 ⁻⁶ |
| C : 2.5V | B : ±50×10 ⁻⁶ |
| D : 1.8V | C : ±30×10 ⁻⁶ |
| | D : ±25×10 ⁻⁶ |
| | E : ±20×10 ⁻⁶ |

When requesting the product, please select the model and function code of your request.

[Type]

DSO211SXF	2016 size
DSO221SXF	2520 size

Standard Specification

Item	Function Code		Output Frequency Range (MHz)	Legend	Spec.			Unit	Condition			
	Supply Voltage	Frequency tolerance			min.	typ.	max.					
Supply Voltage	A	*	1 ≤ f ₀ ≤ 125	V _{cc}	+3.0	+3.3	+3.6	V				
	B				+2.6	+2.8	+3.0					
	C				+2.25	+2.5	+2.75					
	D				+1.6	+1.8	+2.0					
Frequency Tolerance (includes frequency tolerance at room temperature)	*	A	*	f _{tol}	-	-	±100	×10 ⁻⁶	-40 to +125°C	-10 to +70°C (Standard Operating Temperature Range)		
		Z			-	-	±80					
		B			-	-	±50					
		C			-	-	±50		-40 to +85°C			
		D			-	-	±30					
E	-	-	±25	-20 to +70°C								
D	-	-	±20									
Current Consumption	A, B, C, D	*	1 ≤ f ₀ < 40 40 ≤ f ₀ < 100 100 ≤ f ₀ ≤ 125	I _{cc}	-	-	2.4	mA	No Load			
					1 ≤ f ₀ < 40 40 ≤ f ₀ < 100 100 ≤ f ₀ ≤ 125	-	-					4.2
					1 ≤ f ₀ < 40 40 ≤ f ₀ < 100 100 ≤ f ₀ ≤ 125	-	-					10.0
					1 ≤ f ₀ < 40 40 ≤ f ₀ < 100 100 ≤ f ₀ ≤ 125	-	-					2.2
					1 ≤ f ₀ < 40 40 ≤ f ₀ < 100 100 ≤ f ₀ ≤ 125	-	-					3.7
					1 ≤ f ₀ < 40 40 ≤ f ₀ < 100 100 ≤ f ₀ ≤ 125	-	-					9.0
					1 ≤ f ₀ < 40 40 ≤ f ₀ < 100 100 ≤ f ₀ ≤ 125	-	-					2.0
					1 ≤ f ₀ < 40 40 ≤ f ₀ < 100 100 ≤ f ₀ ≤ 125	-	-					3.4
					1 ≤ f ₀ < 40 40 ≤ f ₀ < 100 100 ≤ f ₀ ≤ 125	-	-					8.0
					1 ≤ f ₀ < 40 40 ≤ f ₀ < 100 100 ≤ f ₀ ≤ 125	-	-					1.7
					1 ≤ f ₀ < 40 40 ≤ f ₀ < 100 100 ≤ f ₀ ≤ 125	-	-					2.7
					Stand-by Current (#1 pin "L" Level)	*	*					*
Load Condition	*	*	*	L _{CMOS}	-	-	15	pF				
Symmetry	*	*	*	SYM	45	50	55	%	50% V _{cc} Level			
0 Level Output Voltage	*	*	*	V _{OL}	-	-	V _{cc} ×0.1	V				
1 Level Output Voltage	*	*	*	V _{OH}	V _{cc} ×0.9	-	-	V				
Rise and Fall Time	A, B, C, D	*	*	tr, tf	-	-	3	ns	10 to 90% V _{cc} Level			
OE Pin 0 Level Input Voltage	*	*	*	V _{IL}	-	-	V _{cc} ×0.3	V				
OE Pin 1 Level Input Voltage	*	*	*	V _{IH}	V _{cc} ×0.7	-	-	V				
Output Disable Time	*	*	*	tPLZ	-	-	200	ns				
Output Enable Time	*	*	*	tPZL	-	-	2	ms				
Period Jitter (1)	*	*	*	tRMS	-	2.4	-	ps	σ			
Total Jitter (1)	*	*	*	tp-p	-	23	-	ps	Peak to peak			
Phase Jitter	*	*	40 ≤ f ₀ ≤ 125	tTL	-	34	-	ps	tDJ+n×tRJ n=14.1 (BER=1×10 ⁻¹²) (2)			
			10 ≤ f ₀ < 40		-	-	1	ps	f ₀ offset: 12kHz to 20MHz f ₀ offset: 12kHz to 5MHz			
Packing Unit (3)					3000pcs./reel (φ 180)							

(1) Measured WAVECREST DTS-2075

Consult our sales representative for other specifications.

(2) tDJ: Deterministic jitter tRJ: Random jitter

(3) Moisture prevention packing is unnecessary. Moisture Sensitivity Level: Level1 (IPC/JEDEC J-STD-033)

DSO211SXF

[mm]

DSO221SXF

[mm]

<h4>Dimensions</h4> <p>Pin Connections</p> <table border="1"> <tr><th>Pin No.</th><th>Connection</th></tr> <tr><td>#1</td><td>OE(Output Enable)</td></tr> <tr><td>#2</td><td>GND</td></tr> <tr><td>#3</td><td>Output</td></tr> <tr><td>#4</td><td>V_{cc}</td></tr> </table> <p>Function</p> <table border="1"> <tr><th>#1 Input</th><th>#3 Output condition</th></tr> <tr><td>H</td><td>Oscillation out</td></tr> <tr><td>L</td><td>High Z</td></tr> </table> <h4>Recommended Land Pattern (Top View)</h4>	Pin No.	Connection	#1	OE(Output Enable)	#2	GND	#3	Output	#4	V _{cc}	#1 Input	#3 Output condition	H	Oscillation out	L	High Z	<h4>Dimensions</h4> <p>Pin Connections</p> <table border="1"> <tr><th>Pin No.</th><th>Connection</th></tr> <tr><td>#1</td><td>OE(Output Enable)</td></tr> <tr><td>#2</td><td>GND</td></tr> <tr><td>#3</td><td>Output</td></tr> <tr><td>#4</td><td>V_{cc}</td></tr> </table> <p>Function</p> <table border="1"> <tr><th>#1 Input</th><th>#3 Output condition</th></tr> <tr><td>H</td><td>Oscillation out</td></tr> <tr><td>L</td><td>High Z</td></tr> </table> <h4>Recommended Land Pattern (Top View)</h4>	Pin No.	Connection	#1	OE(Output Enable)	#2	GND	#3	Output	#4	V _{cc}	#1 Input	#3 Output condition	H	Oscillation out	L	High Z
Pin No.	Connection																																
#1	OE(Output Enable)																																
#2	GND																																
#3	Output																																
#4	V _{cc}																																
#1 Input	#3 Output condition																																
H	Oscillation out																																
L	High Z																																
Pin No.	Connection																																
#1	OE(Output Enable)																																
#2	GND																																
#3	Output																																
#4	V _{cc}																																
#1 Input	#3 Output condition																																
H	Oscillation out																																
L	High Z																																

SMD Crystal Oscillators

DSO221SR/DSO321SR/DSO531SR/DSO751SR

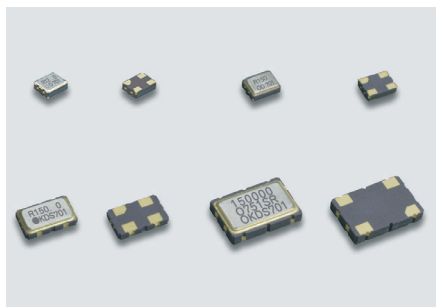

Actual size DSO221SR DSO321SR
DSO531SR DSO751SR

■ Features

- Low current consumption: 8mA max (167MHz, 3.3V)
- Supply Voltage: 1.8V/2.5V/2.8V/3.0V/3.3V
- Offers Narrow deviation: $\pm 20 \times 10^{-6} / \pm 30 \times 10^{-6} / \pm 50 \times 10^{-6} / \pm 100 \times 10^{-6}$
- Available up to 167MHz by using AT cut fundamental resonator.
- Low jitter provides for high performance.
- Low profile: 0.815mm(DSO221SR), 1.1mm(DSO321SR/DSO531SR), 1.5mm(DSO751SR)
- AEC-Q200 Compliant (Option: Equivalent to AEC-Q100) (DSO221SR/DSO321SR)
- CMOS Level Output



[Type]	DSO221SR	2520 size
	DSO321SR	3225 size
	DSO531SR	5032 size
	DSO751SR	7349 size

[Function Code]

DSO***SR

A A

A : 3.3V
M : 3.0V
B : 2.8V
C : 2.5V
D : 1.8V

A : $\pm 100 \times 10^{-6}$
B : $\pm 50 \times 10^{-6}$
C : $\pm 30 \times 10^{-6}$
D : $\pm 25 \times 10^{-6}$
E : $\pm 20 \times 10^{-6}$

■ Standard Specification

When requesting the product, please select the model and function code of your request.

Item	Function Code		Output Frequency Range (MHz)	Legend	Spec.				Condition
	Supply Voltage	Frequency tolerance			min.	typ.	max.	Unit	
Supply Voltage	A	*	$0.2 \leq f_0 \leq 167$	V _{CC}	+3.0	+3.3	+3.6	V	
	M		$0.2 \leq f_0 \leq 167$		+2.7	+3.0	+3.3		
	B		$0.2 \leq f_0 \leq 157$		+2.6	+2.8	+3.0		
	C		$0.2 \leq f_0 \leq 157$		+2.25	+2.5	+2.75		
	D		$0.2 \leq f_0 \leq 80$		+1.6	+1.8	+2.0		
Frequency Tolerance (Includes frequency tolerance at room temperature.)	*	A	$0.2 \leq f_0 \leq 167$	f _{tol}	-100	-	+100	$\times 10^{-6}$	-40 to +85°C -10 to +70°C (Standard Operating Temperature Range)
		B	$0.2 \leq f_0 \leq 125$		-50	-	+50		
		C	$0.2 \leq f_0 \leq 80$		-30	-	+30		
		D	$0.2 \leq f_0 \leq 80$		-25	-	+25		
		E	$0.2 \leq f_0 \leq 50$		-20	-	+20		
Current Consumption	A,M	*	$0.2 \leq f_0 < 32$	I _{CC}	-	-	1.8	mA	No Load
			$32 \leq f_0 < 54$		-	-	2.5		
			$54 \leq f_0 < 80$		-	-	5.0		
			$80 \leq f_0 < 125$		-	-	6.0		
			$125 \leq f_0 \leq 167$		-	-	8.0		
	B	*	$0.2 \leq f_0 < 32$		-	-	1.8		
			$32 \leq f_0 < 54$		-	-	2.5		
			$54 \leq f_0 < 125$		-	-	5.0		
			$125 \leq f_0 \leq 157$		-	-	7.0		
	C	*	$0.2 \leq f_0 < 32$		-	-	1.5		
			$32 \leq f_0 < 54$		-	-	2.0		
			$54 \leq f_0 < 125$		-	-	4.0		
$125 \leq f_0 \leq 157$			-	-	6.0				
D	*	$0.2 \leq f_0 < 32$	-	-	1.0				
		$32 \leq f_0 < 54$	-	-	1.4				
		$54 \leq f_0 \leq 80$	-	-	3.0				
Stand-by Current (#1 pin "L" Level)	*	*	*	I _{std}	-	-	10	μA	
Load Condition	*	*	*	L _{CMOS}	-	-	15	pF	
	A,M	*	$0.2 \leq f_0 \leq 80$		-	-	30		
Symmetry	*	*	$f_0 < 50$	SYM	45	50	55	%	50% V _{CC} Level
			$f_0 \geq 50$		40	50	60		
0 Level Output Voltage	*	*	*	V _{OL}	-	-	V _{CC} × 0.1	V	
1 Level Output Voltage	*	*	*	V _{OH}	V _{CC} × 0.9	-	-		
Rise and Fall Time	A,M,B,C	*	$0.2 \leq f_0 \leq 54$	tr, tf	-	-	5(4)	ns	L _{CMOS} :15pF 10 to 90% V _{CC} Level (20 to 80% V _{CC} Level)
	D		$0.2 \leq f_0 \leq 54$		-	-	7(6)		
	*		$54 < f_0 < 100$		-	-	4(3)		
	*		$100 \leq f_0 \leq 167$		-	-	3(2.5)		
	A,M		$0.2 \leq f_0 \leq 54$		-	-	10		
	A,M		$54 < f_0 \leq 80$		-	-	6		
OE Pin 0 Level Input Voltage	*	*	*	V _{IL}	-	-	V _{CC} × 0.2	V	
OE Pin 1 Level Input Voltage	*	*	*	V _{IH}	V _{CC} × 0.8	-	-		
Output Disable Time	*	*	*	t _{PLZ}	-	-	150	ns	
Output Enable Time	*	*	*	t _{PZL}	-	-	1		
Period Jitter (1)	*	*	*	t _{RMS}	-	2.2	-	ps	σ Peak to peak
					t _{p-p}	-	20		
Total Jitter (1)	*	*	*	t _{TL}	-	31	-	ps	t _{DJ} +n×t _{RJ} n=14.1(BER=1×10 ⁻¹²) (2)
Phase Jitter	*	*	$40 \leq f_0 \leq 167$	tpj	-	-	1		
			$10 \leq f_0 < 40$						
Packing Unit (3)	DSO221SR, DSO321SR: 2000pcs./reel (φ 180) , DSO531SR: 1000pcs./reel (φ 180) , DSO751SR: 1000pcs./reel (φ 254)								

(1) Measured WAVECREST DTS-2075

(2) t_{DJ} : Deterministic jitter t_{RJ} : Random jitter

(3) Moisture prevention packing is unnecessary.

Moisture Sensitivity Level : Level 1 (IPC/JEDEC J-STD-033)

Consult our sales representative for other specifications.

SMD Crystal Oscillators

DSO221SR/DSO321SR/DSO531SR/DSO751SR

Applications

- PC, gaming equipment
- DSC, DVD, Blu-ray, HDTV, DVC, HDD
- WiMAX
- Camera module
- GbEthernet
- Automotive multimedia device

Dimensions

[mm]

Model	Dimensions (mm)	Pin Connections	Function	Recommended Land Pattern (Top View)																		
DSO221SR		<table border="1"> <tr><th>Pin No.</th><th>Connection</th></tr> <tr><td>#1</td><td>OE(Output Enable)</td></tr> <tr><td>#2</td><td>GND</td></tr> <tr><td>#3</td><td>Output</td></tr> <tr><td>#4</td><td>Vcc</td></tr> </table>	Pin No.	Connection	#1	OE(Output Enable)	#2	GND	#3	Output	#4	Vcc	<table border="1"> <tr><th>#1 Input</th><th>#3 Output condition</th></tr> <tr><td>H</td><td>Oscillation out</td></tr> <tr><td>Open</td><td>Oscillation out</td></tr> <tr><td>L</td><td>High Z</td></tr> </table>	#1 Input	#3 Output condition	H	Oscillation out	Open	Oscillation out	L	High Z	
Pin No.	Connection																					
#1	OE(Output Enable)																					
#2	GND																					
#3	Output																					
#4	Vcc																					
#1 Input	#3 Output condition																					
H	Oscillation out																					
Open	Oscillation out																					
L	High Z																					
DSO321SR		<table border="1"> <tr><th>Pin No.</th><th>Connection</th></tr> <tr><td>#1</td><td>OE(Output Enable)</td></tr> <tr><td>#2</td><td>GND</td></tr> <tr><td>#3</td><td>Output</td></tr> <tr><td>#4</td><td>Vcc</td></tr> </table>	Pin No.	Connection	#1	OE(Output Enable)	#2	GND	#3	Output	#4	Vcc	<table border="1"> <tr><th>#1 Input</th><th>#3 Output condition</th></tr> <tr><td>H</td><td>Oscillation out</td></tr> <tr><td>Open</td><td>Oscillation out</td></tr> <tr><td>L</td><td>High Z</td></tr> </table>	#1 Input	#3 Output condition	H	Oscillation out	Open	Oscillation out	L	High Z	
Pin No.	Connection																					
#1	OE(Output Enable)																					
#2	GND																					
#3	Output																					
#4	Vcc																					
#1 Input	#3 Output condition																					
H	Oscillation out																					
Open	Oscillation out																					
L	High Z																					
DSO531SR		<table border="1"> <tr><th>Pin No.</th><th>Connection</th></tr> <tr><td>#1</td><td>OE(Output Enable)</td></tr> <tr><td>#2</td><td>GND</td></tr> <tr><td>#3</td><td>Output</td></tr> <tr><td>#4</td><td>Vcc</td></tr> </table>	Pin No.	Connection	#1	OE(Output Enable)	#2	GND	#3	Output	#4	Vcc	<table border="1"> <tr><th>#1 Input</th><th>#3 Output condition</th></tr> <tr><td>H</td><td>Oscillation out</td></tr> <tr><td>Open</td><td>Oscillation out</td></tr> <tr><td>L</td><td>High Z</td></tr> </table>	#1 Input	#3 Output condition	H	Oscillation out	Open	Oscillation out	L	High Z	
Pin No.	Connection																					
#1	OE(Output Enable)																					
#2	GND																					
#3	Output																					
#4	Vcc																					
#1 Input	#3 Output condition																					
H	Oscillation out																					
Open	Oscillation out																					
L	High Z																					
DSO751SR		<table border="1"> <tr><th>Pin No.</th><th>Connection</th></tr> <tr><td>#1</td><td>OE(Output Enable)</td></tr> <tr><td>#2</td><td>GND</td></tr> <tr><td>#3</td><td>Output</td></tr> <tr><td>#4</td><td>Vcc</td></tr> </table>	Pin No.	Connection	#1	OE(Output Enable)	#2	GND	#3	Output	#4	Vcc	<table border="1"> <tr><th>#1 Input</th><th>#3 Output condition</th></tr> <tr><td>H</td><td>Oscillation out</td></tr> <tr><td>Open</td><td>Oscillation out</td></tr> <tr><td>L</td><td>High Z</td></tr> </table>	#1 Input	#3 Output condition	H	Oscillation out	Open	Oscillation out	L	High Z	
Pin No.	Connection																					
#1	OE(Output Enable)																					
#2	GND																					
#3	Output																					
#4	Vcc																					
#1 Input	#3 Output condition																					
H	Oscillation out																					
Open	Oscillation out																					
L	High Z																					

SMD Crystal Oscillators

DSO321SRS

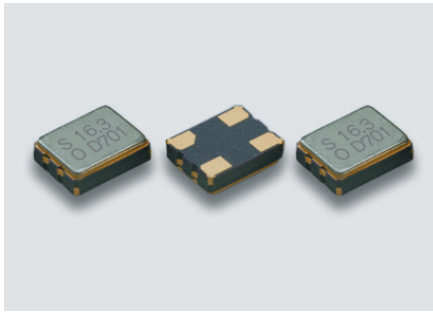

Actual size

Features

- Fast output enable time : 200ns
- 3-state function
- Supply Voltage : 3.3V
- Available frequency range : 8.25 to 66MHz
- CMOS Level Output

Applications

- Visual applications, Sever, SSD
- Industrial equipment

[Function Code]

DSO321SRS

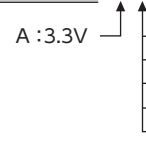

Standard Specification

Item	Function Code		Output Frequency Range (MHz)	Legend	Spec.				Condition	
	Supply Voltage	Frequency tolerance			min.	typ.	max.	Unit		
Supply Voltage	A	*	$8.25 \leq f_o \leq 66$	V _{cc}	+3.0	+3.3	+3.6	V		
Frequency Tolerance (Includes frequency tolerance at room temperature)	*	A	*	f _{tol}	-100	-	+100	×10 ⁻⁶	-40 to +100°C	-10 to +70°C (Standard Operating Temperature Range)
		B			-50	-	+50			
		C			-30	-	+30			
		D			-25	-	+25			
		E			-20	-	+20			
Current Consumption	A	*	$8.25 \leq f_o \leq 16.5$	I _{cc}	-	-	3.7	mA	No Load	
			$16.5 < f_o \leq 33$		-	-	4.1			
			$33 < f_o \leq 66$		-	-	4.8			
Stand-by Current (#1 pin "L" Level)	A	*	$8.25 \leq f_o \leq 16.5$	I _{std}	-	-	2.4	mA	No Load	
			$16.5 < f_o \leq 33$		-	-	2.9			
			$33 < f_o \leq 66$		-	-	3.8			
Load Condition	*	*	*	L _{CMOS}	-	-	15	pF		
Symmetry	*	*	*	SYM	45	50	55	%	at 50% V _{cc}	
0 Level Output Voltage	*	*	*	V _{OL}	-	-	V _{cc} ×0.1	V		
1 Level Output Voltage	*	*	*	V _{OH}	V _{cc} ×0.9	-	-	V		
Rise and Fall Time	*	*	*	tr, tf	-	-	10	ns	10 to 90% V _{cc} Level	
OE Pin 0 Level Input Voltage	*	*	*	V _{IL}	-	-	V _{cc} ×0.2	V		
OE Pin 1 Level Input Voltage	*	*	*	V _{IH}	V _{cc} ×0.8	-	-	V		
Output Disable Time	*	*	*	t _{PLZ}	-	-	100	ns		
Output Enable Time	*	*	*	t _{PZL}	-	-	200	ns		
Period Jitter (1)	*	*	*	t _{RMS}	-	2.2	-	ps	σ	
	*	*	*	t _{p-p}	-	20	-		Peak to peak	
Total Jitter (1)	*	*	*	t _{TL}	-	31	-	ps	t _{DJ} +n×t _{RJ} n=14.1 (BER=1×10 ⁻¹²) (2)	
Phase Jitter	*	*	$40 \leq f_o \leq 66$	tpj	-	-	1		fo offset: 12kHz to 20MHz	
			$10 \leq f_o < 40$						fo offset: 12kHz to 5MHz	
Packing Unit (3)	2000pcs./reel (φ 180)									

(1) Measured WAVECREST DTS-2075

Consult our sales representative for other specifications.

(2) t_{DJ} : Deterministic jitter t_{RJ} : Random jitter

(3) Moisture prevention packing is unnecessary. Moisture Sensitivity Level : Level 1 (IPC/JEDEC J-STD-033)

[mm]

Dimensions

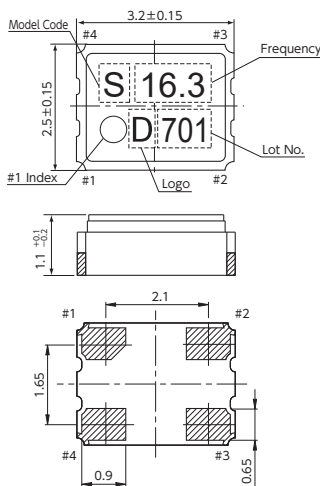

Pin No.	Connection
#1	OE (Output Enable)
#2	GND
#3	Output
#4	V _{cc}

Function	#1 Input	#3 Output condition
H	Oscillation out	Oscillation out
Open	Oscillation out	Oscillation out
L	High Z	High Z

Recommended Land Pattern

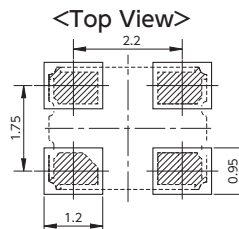

SMD Crystal Oscillators

DSO221SBM/DSO321SBM/DSO531SBM/DSO751SBM

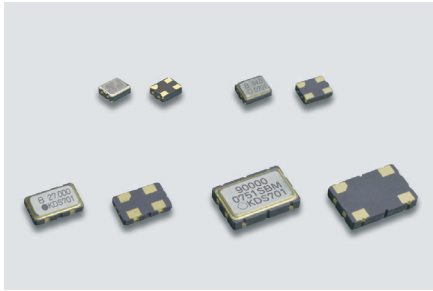

Actual size DSO221SBM DSO321SBM
DSO531SBM DSO751SBM

Features

- Low current consumption
- 3-state function
- General purpose +5.0V HCMOS oscillator
- CMOS Level Output

Applications

- PC, visual and FA equipment applications

[Type]	Model	Size
	DSO221SBM	2520 size
	DSO321SBM	3225 size
	DSO531SBM	5032 size
	DSO751SBM	7349 size

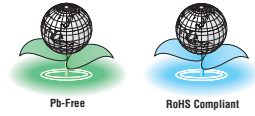

[Function Code]

DSO***SBM Y A
 Y : 5.0V $\left\{ \begin{array}{l} A : \pm 100 \times 10^{-6} \\ B : \pm 50 \times 10^{-6} \\ C : \pm 30 \times 10^{-6} \end{array} \right.$

When requesting the product, please select the model and function code of your request.

Standard Specification

Item	Legend	Function Code		DSO221SBM			DSO321, 531, 751 SBM				Condition		
		Supply Voltage	Frequency tolerance	Output Frequency Range (MHz)	Spec.			Output Frequency Range (MHz)	Spec.				
Supply Voltage	V _{CC}	*	*	3.25 ≤ f ₀ ≤ 52	+4.5	+5.0	+5.5	0.7 ≤ f ₀ ≤ 90	+4.5	+5.0	+5.5	V	
Frequency Tolerance (Includes frequency tolerance at room temperature.)	f _{tol}	*	A	3.25 ≤ f ₀ ≤ 52	-100	-	+100	0.7 ≤ f ₀ ≤ 90	-100	-	+100	X10 ⁻⁶	-40 to +85°C -20 to +70°C (Standard Operating Temperature Range)
			B	3.25 ≤ f ₀ ≤ 52	-50	-	+50	0.7 ≤ f ₀ ≤ 90	-50	-	+50		
			C	3.25 ≤ f ₀ ≤ 52	-30	-	+30	0.7 ≤ f ₀ ≤ 54	-30	-	+30		
Current Consumption	I _{CC}	*	*	3.25 ≤ f ₀ ≤ 52	-	-	8.0	0.7 ≤ f ₀ < 32	-	-	4.0	mA	No Load
								32 ≤ f ₀ < 54	-	-	6.0		
								54 ≤ f ₀ < 90	-	-	8.0		
Stand-by Current (#1 pin "L" Level)	I _{std}	*	*	*	-	-	10	*	-	-	50	μA	
Load Condition	L _{CMOS}	*	*	*	-	-	15	*	-	-	30	pF	
Symmetry	SYM	*	*	*	45	50	55	f ₀ < 26	45	50	55	%	50% V _{CC} Level
0 Level Output Voltage	V _{OL}	*	*	*	-	-	V _{CC} × 0.1	*	-	-	V _{CC} × 0.1	V	
1 Level Output Voltage	V _{OH}	*	*	*	V _{CC} × 0.9	-	-	*	V _{CC} × 0.9	-	-	V	
Rise and Fall Time	t _r , t _f	*	*	3.25 ≤ f ₀ ≤ 52	-	-	4.0	0.7 ≤ f ₀ ≤ 54	-	-	7 (6)	ns	L _{CMOS} : 30pF 10 to 90% V _{CC} Level (20 to 80% V _{CC} Level)
								54 < f ₀ ≤ 90	-	-	5 (4)		
OE Pin 0 Level Input Voltage	V _{IL}	*	*	*	-	-	V _{CC} × 0.2	*	-	-	V _{CC} × 0.2	V	
OE Pin 1 Level Input Voltage	V _{IH}	*	*	*	V _{CC} × 0.8	-	-	*	V _{CC} × 0.8	-	-	V	
Output Disable Time	t _{PLZ}	*	*	*	-	-	100	*	-	-	150	ns	
Output Enable Time	t _{PZL}	*	*	*	-	-	2.0	*	-	-	1	ms	
Period Jitter (1)	t _{RMS}	*	*	*	-	2.5	-	*	-	2.5	-	ps	σ Peak to peak
	t _{p-p}	*	*	*	-	20	-	*	-	20	-		
Total Jitter (1)	t _{TJ}	*	*	*	-	35	-	*	-	35	-	ps	t _{DJ} + n × t _{RJ} n=14.1 (BER=1 × 10 ⁻¹²) (2)
Phase Jitter	t _{pj}	*	*	40 ≤ f ₀ ≤ 52	-	-	1	40 ≤ f ₀ ≤ 90	-	-	1	ps	fo offset: 12kHz to 20MHz fo offset: 12kHz to 5MHz
				10 ≤ f ₀ < 40	-	-	1	10 ≤ f ₀ < 40	-	-	1		
Packing Unit (3)	DSO221SBM, DSO321SBM: 2000pcs./reel (φ 180), DSO531SBM: 1000pcs./reel (φ 180), DSO751SBM: 1000pcs./reel (φ 254)												

(1) Measured WAVECREST DTS-2075
 (2) t_{DJ}: Deterministic jitter t_{RJ}: Random jitter
 (3) Moisture prevention packing is unnecessary.
 Moisture Sensitivity Level: Level 1 (IPC/JEDEC J-STD-033)

Consult our sales representative for other specifications.

DSO221SBM [mm] ■ DSO321SBM [mm] ■ DSO531SBM [mm] ■ DSO751SBM [mm]

Model	Dimensions (mm)	Recommended Land Pattern (Top View)
DSO221SBM	<p>Model Code: #4 #3 #2 #1 Frequency Lot No. #1 Index #1 #2</p> <p>2.5 ± 0.15 2.0 ± 0.15 0.81 ± 0.08 1.58 1.23 0.68 0.53</p>	<p>Pin Connections #1 OE/Output Enable #2 GND #3 Output #4 V_{CC}</p> <p>Function #1 Input #3 Output condition H Oscillation out Open Oscillation out L High Z</p>
DSO321SBM	<p>Model Code: #4 #3 #2 #1 Frequency Lot No. #1 Index #1 #2</p> <p>3.2 ± 0.15 2.5 ± 0.15 1.1 ± 0.1 2.1 1.65 0.65</p>	<p>Pin Connections #1 OE/Output Enable #2 GND #3 Output #4 V_{CC}</p> <p>Function #1 Input #3 Output condition H Oscillation out Open Oscillation out L High Z</p>
DSO531SBM	<p>Model Code: #4 #3 #2 #1 Frequency Lot No. #1 Index #1 #2</p> <p>5.0 ± 0.2 3.2 ± 0.2 1.1 ± 0.1 2.54 2.10 1.2 0.9</p>	<p>Pin Connections #1 OE/Output Enable #2 GND #3 Output #4 V_{CC}</p> <p>Function #1 Input #3 Output condition H Oscillation out Open Oscillation out L High Z</p>
DSO751SBM	<p>Model Code: #4 #3 #2 #1 Frequency (1kHz) Lot No. #1 Index #1 #2</p> <p>7.3 ± 0.2 4.9 ± 0.2 1.5 ± 0.2 5.08 3.65 1.4 1.4</p>	<p>Pin Connections #1 OE/Output Enable #2 GND #3 Output #4 V_{CC}</p> <p>Function #1 Input #3 Output condition H Oscillation out Open Oscillation out L High Z</p>

SMD Crystal Oscillators

DSO1612AR (kHz)

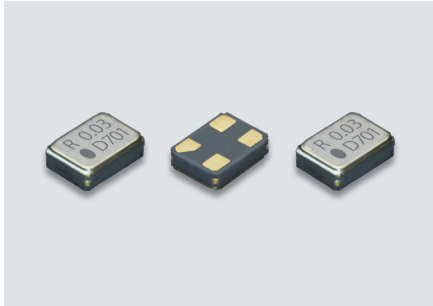

Actual size □

Features

- 1612 size, 0.5mm height, ultra miniature and lightweight
- Output Frequency : 32.768kHz
- Supply Voltage : 1.8V/2.5V/2.8V/3.0V/3.3V
- Low current consumption: 18μA typ
- Stable frequency variation realized by adopting an At cut resonator
- Capable of operating over a wide temperature range, from -40 to +125°C
- CMOS Level Output
- 3-state function



Applications

- Short-range wireless modules, PC, multimedia devices, industrial measuring equipment, consumer product

[Function Code]

DSO1612AR

Function Code	Supply Voltage	Frequency Tolerance
A	3.3V	±100×10 ⁻⁶
M	3.0V	±80×10 ⁻⁶
B	2.8V	±50×10 ⁻⁶
C	2.5V	±30×10 ⁻⁶
D	1.8V	±25×10 ⁻⁶
E	1.8V	±20×10 ⁻⁶

When requesting the product, please select the model and function code of your request.

Standard Specification

Item	Function Code		Output Frequency (kHz)	Legend	Spec.			Unit	Condition	
	Supply Voltage	Frequency tolerance			min.	typ.	max.			
Supply Voltage	A	*	*	V _{cc}	+3.0	+3.3	+3.6	V		
	M				+2.7	+3.0	+3.3			
	B				+2.6	+2.8	+3.0			
	C				+2.25	+2.5	+2.75			
	D				+1.6	+1.8	+2.0			
Frequency Tolerance (includes frequency tolerance at room temperature)	*	Y	*	f _{tol}	-	-	±100	×10 ⁶	-40 to +125°C	-10 to +70°C (Standard Operating Temperature Range)
	*	Z			-	-	±80		-40 to +110°C	
	*	A			-	-	±100		-40 to +85°C	
	*	B			-	-	±50		-20 to +70°C	
	*	C			-	-	±30			
	*	D			-	-	±25			
Current Consumption	*	*	*	I _{cc}	-	18	32	μA	No Load	
Stand-by Current (#1 pin "L" Level)	*	*	*	I _{std}	-	-	5	μA		
Load Condition	*	*	*	L _{CMOS}	-	-	15	pF		
Symmetry	*	*	*	SYM	45	50	55	%	50% V _{cc} Level	
0 Level Output Voltage	*	*	*	V _{OL}	-	-	V _{cc} ×0.1	V		
1 Level Output Voltage	*	*	*	V _{OH}	V _{cc} ×0.9	-	-			
Rise and Fall Time	*	*	*	t _r , t _f	-	-	50	ns	10 to 90% V _{cc} Level	
OE Pin 0 Level Input Voltage	*	*	*	V _{IL}	-	-	V _{cc} ×0.3	V		
OE Pin 1 Level Input Voltage	*	*	*	V _{IH}	V _{cc} ×0.7	-	-			
Output Disable Time	*	*	*	t _{PLZ}	-	-	1	μs		
Output Enable Time	*	*	*	t _{PZL}	-	-	10	ms		
Packing Unit (1)	3000pcs./reel (φ180)									

(1) Moisture prevention packing is unnecessary.
Moisture Sensitivity Level : Level1 (IPC/JEDEC J-STD-033)

Consult our sales representative for other specifications.

[mm]

Dimensions

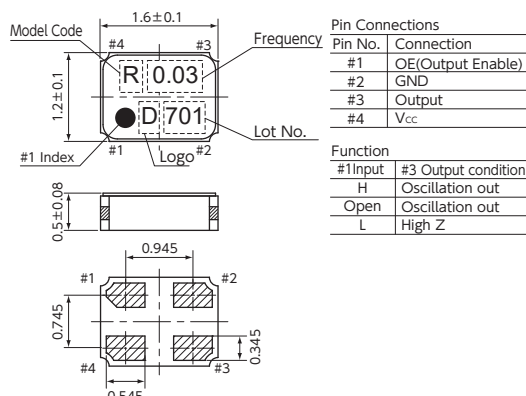

Recommended Land Pattern

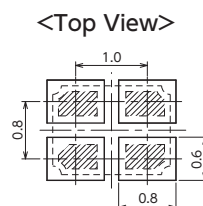

SMD Crystal Oscillators

DSO221SY/DSO321SY

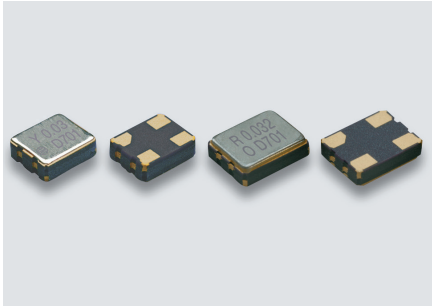

Actual size DSO221SY DSO321SY

Features

- Available frequency range : 32.768kHz, 1.049 to 8.5MHz
- Supply Voltage: 1.8V/2.5V/2.8V/3.3V
- 3-state function
- Low current consumption: 10μA typ.(32.768kHz)
- CMOS Level Output
- Stable frequency variation realized by adopting an At cut resonator
- AEC-Q200 Compliant (Option: Equivalent to AEC-Q100)



Applications

- Timer module, Industrial measuring equipment, Consumer Product

[Type]

DSO221SY	2520 size
DSO321SY	3225 size

[Function Code]

DSO***SY AA

A : 3.3V	A : ±100×10 ⁻⁶
B : 2.8V	B : ±50×10 ⁻⁶
C : 2.5V	N : ±35×10 ⁻⁶
D : 1.8V	C : ±30×10 ⁻⁶
	D : ±25×10 ⁻⁶

When requesting the product, please select the model and function code of your request.

Standard Specification

Item	Function Code		Output Frequency Range	Legend	Spec.				Condition	
	Supply Voltage	Frequency tolerance			min.	typ.	max.	Unit		
Supply Voltage	A	*	32.768kHz 1.049 ≤ f ₀ ≤ 8.5MHz	V _{cc}	+3.0	+3.3	+3.6	V		
	B				+2.6	+2.8	+3.0			
	C				+2.25	+2.5	+2.75			
	D				+1.6	+1.8	+2.0			
Frequency Tolerance (includes frequency tolerance at room temperature)	*	A	32.768kHz 1.049 ≤ f ₀ ≤ 8.5MHz	f _{tol}	-100	-	+100	× 10 ⁻⁶	-40 to +85°C	-10 to +70°C (Standard Operating Temperature Range)
		B			-50	-	+50			
		N			-35	-	+35			
		C			-30	-	+30			
Current Consumption	*	*	32.768kHz 1.049 ≤ f ₀ ≤ 8.5MHz	I _{cc}	-	-	18	μA	No Load	
					-	-	700			
Stand-by Current (#1 pin "L" Level)	*	*	*	I _{std}	-	-	3	μA	-40 to +85°C	
Load Condition	*	*	*	L _{CMOS}	-	-	15	pF		
Symmetry	*	*	32.768kHz 1.049 ≤ f ₀ ≤ 8.5MHz	SYM	45 40	50 50	55 60	%	at 50% V _{cc}	
0 Level Output Voltage	*	*	*	V _{OL}	-	-	V _{cc} ×0.1	V		
1 Level Output Voltage	*	*	*	V _{OH}	V _{cc} ×0.9	-	-	V		
Rise and Fall Time	*	*	*	tr, tf	-	-	15	ns	10 to 90% V _{cc} Level	
OE Pin 0 Level Input Voltage	*	*	*	V _{IL}	-	-	V _{cc} ×0.2	V		
OE Pin 1 Level Input Voltage	*	*	*	V _{IH}	V _{cc} ×0.8	-	-	V		
Output Disable Time	*	*	*	tPLZ	-	-	100	ns		
Output Enable Time	*	*	*	tPZL	-	-	20	ms		
Packing Unit (1)	2000pcs./reel (φ 180)									

(1) Moisture prevention packing is unnecessary.
Moisture Sensitivity Level : Level 1 (IPC/JEDEC J-STD-033)

Consult our sales representative for other specifications.

DSO221SY

[mm] DSO321SY

[mm]

Dimensions

Model Code: Y 0.03 D:701

Pin Connections:

Pin No.	Connection
#1	OE(Output Enable)
#2	GND
#3	Output
#4	V _{cc}

Function:

#1 Input	#3 Output condition
H	Oscillation out
Open	Oscillation out
L	High Z

Recommended Land Pattern (Top View)

Dimensions

Model Code: Y 0.032 D:701

Pin Connections:

Pin No.	Connection
#1	OE(Output Enable)
#2	GND
#3	Output
#4	V _{cc}

Function:

#1 Input	#3 Output condition
H	Oscillation out
Open	Oscillation out
L	High Z

Recommended Land Pattern (Top View)

SMD Differential Output Crystal Oscillators

DSO223SK/DSO323SK/DSO223SJ/DSO323SJ/DSO223SD/DSO323SD

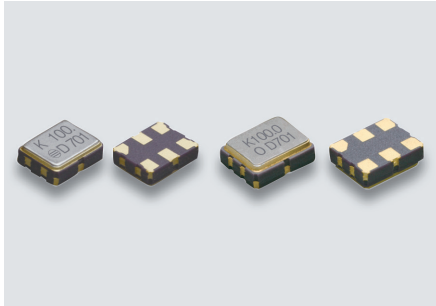

Actual size DSO223S DSO323S

Features

- 2.5V/3.3V operating voltage, High speed type
- 3-state function
- LV-PECL output (DSO223/323SK)
- LVDS output (DSO223/323SJ)
- HCSL output (DSO223/323SD)
- DSO223SK/SJ/SD: AEC-Q200 Compliant
- DSO323SK/SJ/SD: AEC-Q200 Compliant (Option: Equivalent to AEC-Q100)

Applications

- Sever, Optical transmission device, Communication base station and Automotive multimedia device



[Type]

DSO223S SERIES	2520 size
DSO323S SERIES	3225 size

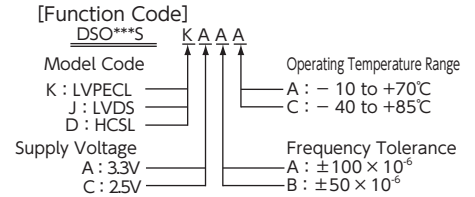

Standard Specification

When requesting the product, please select the model and function code of your request.

Item	Type	Legend	DSO223SK DSO323SK	DSO223SJ DSO323SJ	DSO223SD DSO323SD
Output Specification	—		LV-PECL	LVDS	HCSL
Output Frequency Range	f_o		13.5 to 167MHz (DSO223S SERIES) / 13.5 to 212.5MHz (DSO323S SERIES)		
Supply Voltage	V_{CC}		+2.5V \pm 0.125V/+3.3V \pm 0.165V		
Frequency Tolerance (Includes frequency tolerance at room temperature.)	f_{tol}		$\pm 50 \times 10^{-6}$ max., $\pm 100 \times 10^{-6}$ max.		
Storage Temperature Range	T_{stg}		-40 to +85°C		
Operating Temperature Range	T_{use}		-10 to +70°C, -40 to +85°C		
Current Consumption	I_{CC}		45mA max. ($f_o \leq 170$ MHz), 50mA max. (170MHz $< f_o \leq 212.5$ MHz)	20mA max.	30mA max. ($f_o \leq 170$ MHz), 35mA max. (170MHz $< f_o \leq 212.5$ MHz)
Stand-by Current (#1 pin "L" Level)	I_{std}		10 μ A max.		
Load Condition	Load-R		50 Ω to $V_{CC}-2V$	100 Ω (Output-OutputN)	50 Ω
Symmetry	SYM		45 to 55% [at outputs cross point]		
0 Level Output Voltage	V_{OL}		$V_{CC}-1.81$ to $V_{CC}-1.62V$	—	-0.15 to 0.15V
1 Level Output Voltage	V_{OH}		$V_{CC}-1.025$ to $V_{CC}-0.88V$	—	0.58 to 0.85V
Rise and Fall Time	t_r, t_f		0.5ns max. [20 to 80% Output, OutputN]	0.4ns max. [20 to 80% Output-OutputN]	0.5ns max. [0.175 to 0.525V Level]
Differential Output Voltage	V_{OD1}, V_{OD2}		—	0.247 to 0.454V	—
Change to V_{OD}	ΔV_{OD}		—	50mV [$\Delta V_{OD} = V_{OD1} - V_{OD2} $]	—
Offset Voltage	V_{OS}		—	1.125 to 1.375V	—
Offset to V_{OS}	ΔV_{OS}		—	50mV	—
Crossing Point Voltage	V_{cr}		—	—	250 to 550mV
OE Pin 0 Level Input Voltage	V_{IL}		$V_{CC} \times 0.3$ max.		
OE Pin 1 Level Input Voltage	V_{IH}		$V_{CC} \times 0.7$ min.		
Output Disable Time	t_{PLZ}		200ns		
Output Enable Time	t_{PZL}		2ms		
Period Jitter (1)	t_{RMS}		5ps typ. (13.5MHz $\leq f_o < 27$ MHz) / 2.5ps typ. (27MHz $\leq f_o \leq 212.5$ MHz) (σ)		
	t_{p-p}		33ps typ. (13.5MHz $\leq f_o < 27$ MHz) / 22ps typ. (27MHz $\leq f_o \leq 212.5$ MHz) (Peak to peak)		
Total Jitter (1)	t_{TL}		50ps typ. (13.5MHz $\leq f_o < 27$ MHz) / 35ps typ. (27MHz $\leq f_o \leq 212.5$ MHz) [$t_{DJ} + n \times t_{RJ}$ n=14.1 (BER=1 $\times 10^{-12}$) (2)]		
Phase Jitter	t_{pj}		1.5ps max. (13.5MHz $\leq f_o < 27$ MHz) / 1ps max. (27MHz $\leq f_o \leq 212.5$ MHz) [13.5MHz $\leq f_o < 40$ MHz, f_o offset: 12kHz to 5MHz $f_o \geq 40$ MHz, f_o offset: 12kHz to 20MHz]		
Packing Unit (3)	—		2000pcs./reel ($\phi 180$)		

- (1) Measured WAVECREST DTS-2075
 (2) t_{DJ} : Deterministic jitter t_{RJ} : Random jitter
 (3) Moisture prevention packing is unnecessary.
 Moisture Sensitivity Level: Level 1 (IPC/JEDEC J-STD-033)

Consult our sales representative for other specifications.

DSO223S SERIES

[mm] DSO323S SERIES

[mm]

Dimensions

Model Code

DSO223S: J

DSO223SK (2.5V): KB

DSO223SK (3.3V): K

DSO223SD: D

Pin Connections

Pin No.	Connection
#1	OE(Output Enable)
#2	NC
#3	GND
#4	Output
#5	OutputN
#6	V _{CC}

Function

#1 Input	#4,#5 Output condition
H	Oscillation out
Open	Oscillation out
L	High Z

Recommended Land Pattern

Dimensions

Model Code

DSO323S: J

DSO323SK (2.5V): KB

DSO323SK (3.3V): K

DSO323SD: D

Pin Connections

Pin No.	Connection
#1	OE(Output Enable)
#2	NC
#3	GND
#4	Output
#5	OutputN
#6	V _{CC}

Function

#1 Input	#4,#5 Output condition
H	Oscillation out
Open	Oscillation out
L	High Z

Recommended Land Pattern

SMD Differential Output Crystal Oscillators - Low Voltage

DSO323SJ/DSO323SD

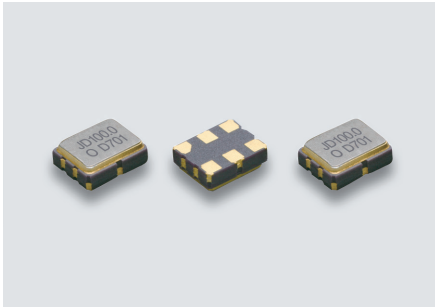

Actual size

Features

- 1.8V operating voltage, High speed type
- 3-state function
- LVDS output (DSO323SJ)
- HCSL output (DSO323SD)
- AEC-Q200 Compliant (Option: Equivalent to AEC-Q100)

Applications

- Sever, Optical transmission device, Communication base station and Automotive multimedia device

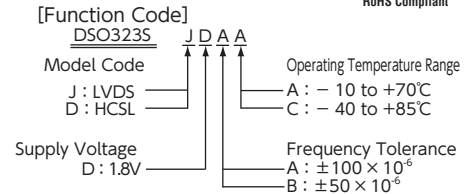

When requesting the product, please select the model and function code of your request.

Standard Specification

Item	Type	Legend	DSO323SJ	DSO323SD
Output Specification	—		LVDS	HCSL
Output Frequency Range	f_0		100 to 167MHz	
Supply Voltage	V_{CC}		$+1.8V \pm 0.09V$	
Frequency Tolerance (Includes frequency tolerance at room temperature)	f_{tol}		$\pm 50 \times 10^{-6}$ max., $\pm 100 \times 10^{-6}$ max.	
Storage Temperature Range	T_{stg}		-40 to +85°C	
Operating Temperature Range	T_{use}		-10 to +70°C, -40 to +85°C	
Current Consumption	I_{CC}		25mA max.	50mA max.
Stand-by Current (#1 pin "L" Level)	I_{std}		30 μA max.	
Load Condition	Load-R		100 Ω (Output-OutputN)	50 Ω
Symmetry	SYM		45 to 55% [at outputs cross point]	
0 Level Output Voltage	V_{OL}		—	-0.15 to 0.15V
1 Level Output Voltage	V_{OH}		—	0.55 to 1.0V
Rise and Fall Time	t_r, t_f		0.4ns max. [20 to 80% Output-OutputN]	0.5ns max. [-0.15 to 0.15V/Output-OutputN]
Differential Output Voltage	V_{OD1}, V_{OD2}		0.247 to 0.454V	—
Change to V_{OD}	ΔV_{OD}		50mV [$\Delta V_{OD} = V_{OD1} - V_{OD2} $]	—
Offset Voltage	V_{OS}		1.125 to 1.375V	—
Offset to V_{OS}	ΔV_{OS}		50mV	—
OE Pin 0 Level Input Voltage	V_{IL}		$V_{CC} \times 0.3$ max.	
OE Pin 1 Level Input Voltage	V_{IH}		$V_{CC} \times 0.7$ min.	
Output Disable Time	t_{PLZ}		200ns	
Output Enable Time	t_{PZL}		2ms	
Period Jitter (1)	t_{RMS}		2.5ps typ. (σ)	
	t_{p-p}		22ps typ. (Peak to peak)	
Total Jitter (1)	t_{TL}		35ps typ. [$t_{DJ} + n \times t_{RJ}$ n=14.1 (BER=1 $\times 10^{-12}$) (2)]	
Phase Jitter	t_{pj}		0.15ps max.	
Packing Unit (3)	—		2000pcs./reel ($\phi 180$)	

- (1) Measured WAVECREST DTS-2075
- (2) t_{DJ} : Deterministic jitter t_{RJ} : Random jitter
- (3) Moisture prevention packing is unnecessary.
Moisture Sensitivity Level : Level 1 (IPC/JEDEC J-STD-033)

Consult our sales representative for other specifications.

DSO323S SERIES

[mm]

Dimensions

Model Code
DSO323SJ/JD
DSO323SD/DD

Pin Connections

Pin No.	Connection
#1	OE(Output Enable)
#2	NC
#3	GND
#4	Output
#5	OutputN
#6	Vcc

Function

#1 Input	#4,#5 Output condition
H	Oscillation out
Open	Oscillation out
L	High Z

Recommended Land Pattern

<Top View>

SMD Differential Output Crystal Oscillators

DSO533SK/DSO533SJ

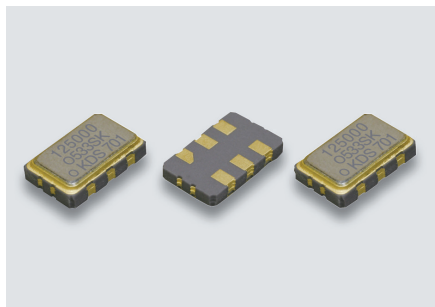

Actual size

Features

- 5032 size, 1.1mm height
- 2.5V/3.3V operating voltage, High speed type (13.5 to 212.5MHz)
- 3-state function
- LV-PECL output (DSO533SK)
- LVDS output (DSO533SJ)

Applications

- Sever, SONET/SDH, PC



Standard Specification

Item	Type	Legend	DSO533SK	DSO533SJ
Output Specification	-	-	LV-PECL	LVDS
Output Frequency Range	f_0	-	13.5 to 212.5MHz	
Supply Voltage	V_{CC}	-	+2.5V \pm 0.125V/+3.3V \pm 0.165V	
Frequency Tolerance (Includes frequency tolerance at room temperature.)	f_{tol}	-	$\pm 50 \times 10^{-6}$ max., $\pm 100 \times 10^{-6}$ max.	
Storage Temperature Range	T_{stg}	-	-40 to +85°C	
Operating Temperature Range	T_{use}	-	-10 to +70°C, -40 to +85°C	
Current Consumption	I_{CC}	-	45mA max. ($f_0 \leq 170$ MHz), 50mA max. (170 MHz $< f_0 \leq 212.5$ MHz)	20mA max.
Stand-by Current (#1 pin "L" Level)	I_{std}	-	10 μ A max.	
Load Condition	Load-R	-	50 Ω to $V_{CC}-2V$	100 Ω (Output-OutputN)
Symmetry	SYM	-	45 to 55% [at outputs cross point]	
0 Level Output Voltage	V_{OL}	-	$V_{CC}-1.81$ to $V_{CC}-1.62V$	-
1 Level Output Voltage	V_{OH}	-	$V_{CC}-1.025$ to $V_{CC}-0.88V$	-
Rise and Fall Time	t_r, t_f	-	0.5ns max. [20 to 80% Output, OutputN]	0.4ns max. [20 to 80% Output-OutputN]
Differential Output Voltage	V_{OD1}, V_{OD2}	-	-	0.247 to 0.454V
Change to V_{OD}	ΔV_{OD}	-	-	50mV [$\Delta V_{OD} = V_{OD1} - V_{OD2} $]
Offset Voltage	V_{OS}	-	-	1.125 to 1.375V
Offset to V_{OS}	ΔV_{OS}	-	-	50mV
OE Pin 0 Level Input Voltage	V_{IL}	-	$V_{CC} \times 0.3$ max.	
OE Pin 1 Level Input Voltage	V_{IH}	-	$V_{CC} \times 0.7$ min.	
Output Disable Time	t_{PLZ}	-	200ns	
Output Enable Time	t_{PZL}	-	2ms	
Period Jitter (1)	t_{RMS}	-	5ps typ. (13.5MHz $\leq f_0 < 27$ MHz) / 2.5ps typ. (27MHz $\leq f_0 \leq 212.5$ MHz) (σ)	
	t_{p-p}	-	33ps typ. (13.5MHz $\leq f_0 < 27$ MHz) / 22ps typ. (27MHz $\leq f_0 \leq 212.5$ MHz) (Peak to peak)	
Total Jitter (1)	t_{TL}	-	50ps typ. (13.5MHz $\leq f_0 < 27$ MHz) / 35ps typ. (27MHz $\leq f_0 \leq 212.5$ MHz) [$t_{DJ} + n \times t_{RJ}$ n=14.1 (BER=1 $\times 10^{-12}$) (2)]	
Phase Jitter	t_{pj}	-	1.5ps max. (13.5MHz $\leq f_0 < 27$ MHz) / 1ps max. (27MHz $\leq f_0 \leq 212.5$ MHz) [13.5MHz $\leq f_0 < 40$ MHz, f_0 offset: 12kHz to 5MHz $f_0 \geq 40$ MHz, f_0 offset: 12kHz to 20MHz]	
Packing Unit (3)	-	-	1000pcs./reel (ϕ 180)	

- (1) Measured WAVECREST DTS-2075
- (2) t_{DJ} : Deterministic jitter t_{RJ} : Random jitter
- (3) Moisture prevention packing is unnecessary.
Moisture Sensitivity Level: Level 1 (IPC/JEDEC J-STD-033)

Consult our sales representative for other specifications.

[mm]

Dimensions

Frequency (kHz)

Model Code

Lot No.

#1 Index

#2 Logo

#3

#4

#5

#6

Recommended Land Pattern

<Top View>

Pin No.	Connection
#1	OE(Output Enable)
#2	NC
#3	GND
#4	Output
#5	OutputN
#6	V_{CC}

Function	
#1 Input	#4,#5 Output condition
H	Oscillation out
Open	Oscillation out
L	High Z

DSO533SJ(2.5V,3.3V) → O533SJ
DSO533SK(2.5V) → O533SKB
DSO533SK(3.3V) → O533SK

SMD Differential Output Crystal Oscillators

DSO753SK/DSO753SJ/DSO753SD

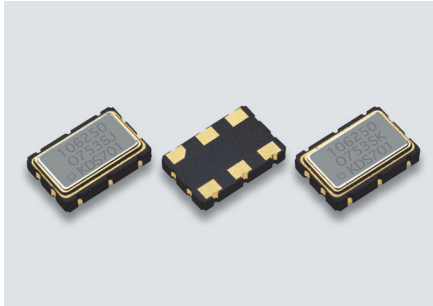

Actual size

■ Features

- Package size : 7.3×4.9×1.5mm
- 2.5V/3.3V operating voltage, High speed type (13.5 to 212.5MHz)
- 3-state function
- LV-PECL output (DSO753SK)
- LVDS output (DSO753SJ)
- HCSL output (DSO753SD)

■ Applications

- Server, FC-HBA



■ Standard Specification

Item	Type	Legend	DSO753SK	DSO753SJ	DSO753SD
Output Specification	-	-	LV-PECL	LVDS	HCSL
Output Frequency Range	f_o	-	13.5 to 212.5MHz		
Supply Voltage	V_{cc}	-	+2.5V±0.125V/+3.3V±0.165V		
Frequency Tolerance (Includes frequency tolerance at room temperature.)	f_{tol}	-	±50×10 ⁻⁶ max., ±100×10 ⁻⁶ max.		
Storage Temperature Range	T_{stg}	-	-40 to +85°C		
Operating Temperature Range	T_{use}	-	-10 to +70°C, -40 to +85°C		
Current Consumption	I_{cc}	-	45mA max. ($f_o \leq 170$ MHz), 50mA max. (170MHz < $f_o \leq 212.5$ MHz)	20mA max.	30mA max. ($f_o \leq 170$ MHz), 35mA max. (170MHz < $f_o \leq 212.5$ MHz)
Stand-by Current (#1 pin "L" Level)	I_{std}	-	10µA max.		
Load Condition	Load-R	-	50Ω to $V_{CC}-2V$	100Ω (Output-OutputN)	50Ω
Symmetry	SYM	-	45 to 55% [at outputs cross point]		
0 Level Output Voltage	V_{OL}	-	$V_{CC}-1.81$ to $V_{CC}-1.62V$	-	-0.15 to 0.15V
1 Level Output Voltage	V_{OH}	-	$V_{CC}-1.025$ to $V_{CC}-0.88V$	-	0.58 to 0.85V
Rise and Fall Time	t_r, t_f	-	0.5ns max. [20 to 80% Output, OutputN]	0.4ns max. [20 to 80% Output-OutputN]	0.5ns max. [0.175 to 0.525V Level]
Differential Output Voltage	V_{OD1}, V_{OD2}	-	-	0.247 to 0.454V	-
Change to V_{od}	ΔV_{od}	-	-	50mV [$\Delta V_{od} = V_{OD1} - V_{OD2} $]	-
Offset Voltage	V_{os}	-	-	1.125 to 1.375V	-
Offset to V_{os}	ΔV_{os}	-	-	50mV	-
Crossing Point Voltage	V_{cr}	-	-	-	250 to 550mV
OE Pin 0 Level Input Voltage	V_{IL}	-	$V_{CC} \times 0.3$ max.		
OE Pin 1 Level Input Voltage	V_{IH}	-	$V_{CC} \times 0.7$ min.		
Output Disable Time	t_{PLZ}	-	200ns		
Output Enable Time	t_{PZL}	-	2ms		
Period Jitter (1)	t_{RMS}	-	5ps typ. (13.5MHz ≤ f_o < 27MHz) / 2.5ps typ. (27MHz ≤ f_o ≤ 212.5MHz) (σ)		
	t_{p-p}	-	33ps typ. (13.5MHz ≤ f_o < 27MHz) / 22ps typ. (27MHz ≤ f_o ≤ 212.5MHz) (Peak to peak)		
Total Jitter (1)	t_{TL}	-	50ps typ. (13.5MHz ≤ f_o < 27MHz) / 35ps typ. (27MHz ≤ f_o ≤ 212.5MHz) [$t_{DJ} + n \times t_{RJ}$ n=14.1 (BER=1×10 ⁻¹²) (2)]		
Phase Jitter	t_{pj}	-	1.5ps max. (13.5MHz ≤ f_o < 27MHz) / 1ps max. (27MHz ≤ f_o ≤ 212.5MHz) [13.5MHz ≤ f_o < 40MHz, f_o offset: 12kHz to 5MHz f_o ≥ 40MHz, f_o offset: 12kHz to 20MHz]		
Packing Unit (3)	-	-	1000pcs./reel (φ254)		

- (1) Measured WAVECREST DTS-2075
 (2) t_{DJ} : Deterministic jitter t_{RJ} : Random
 (3) Moisture prevention packing is unnecessary.
 Moisture Sensitivity Level: Level 1 (IPC/JEDEC J-STD-033)

Consult our sales representative for other specifications.

[mm]

■ Dimensions

■ Recommended Land Pattern

<Top View>

Model Code
 DSO753SJ (2.5V, 3.3V) → O753SJA
 DSO753SK (2.5V) → O753SKB
 DSO753SK (3.3V) → O753SKA
 DSO753SD (2.5V, 3.3V) → O753SDA

Pin Connections

Pin No.	Connection
#1	OE (Output Enable)
#2	NC
#3	GND
#4	Output
#5	OutputN
#6	V_{CC}

Function

#1 Input	#4/#5 Output condition
H	Oscillation out
Open	Oscillation out
L	High Z

Crystal Oscillators

DLO555MBA

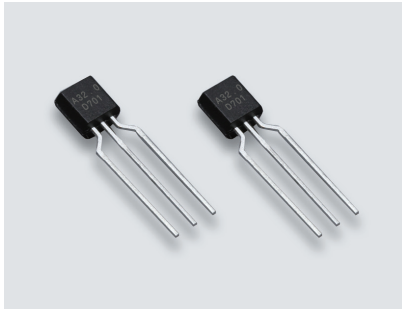

Features

- Small crystal oscillator in TO92 package
- Built-in bypass capacitor to improve noise resistance
- No PLL, No multiplier in oscillation circuit (The divider circuit, some cases be used)
- High-speed oscillation start up time(1ms)
- CMOS Level Output

Type D L O 5 5 5 M B A

① ② ③ ④ ⑤ ⑥ ⑦ ⑧ ⑨

- ① D : Corporate name (Daishinku)
- ② L : Lead type
- ③ O : SPXO
- ④, ⑤ 5 : Dimensions
- ⑥ 5 : 3 terminals
- ⑦ M : Mold type
- ⑧ B : Vcc : 5V, CMOS Level Output
- ⑨ A : Improved impact electric field resistance



Applications

- Gaming equipment
- Industrial equipment

Absolute Maximum Ratings

Item	Legend	Spec.	Unit
Supply Voltage	V _{CC}	-0.5 to +6.0	V
Output Pin Voltage	V _{OUT}	-0.5 to V _{CC} +0.5	V
Output Pin Current	I _{OUT}	10	mA
Storage Temperature Range	T _{str}	-40 to +105	°C

Recommended Operating Conditions

Item	Legend	min.	typ.	max.	Unit
Supply Voltage	V _{CC}	3.0	5.0	5.5	V
Load Condition	L _{CMOS}	-	-	15	pF
				30	
Operating Temperature Range	T _{opr}	-10	-	+85	°C

Standard Specification

Item	Legend	Spec.			Unit	Condition
		min.	typ.	max.		
Output Frequency Range	f ₀	1.5	-	54	MHz	L _{CMOS} : 30pF
Frequency Tolerance	f _{tol}	-100	-	+100	×10 ⁻⁶	T _{opr} = -10 to +85°C V _{CC} =+3.0 to +5.5V
		-50		+50		
Aging	-	-	-	±5	×10 ⁻⁶ /year	
Current Consumption	I _{CC}	-	-	8	mA	No load
Symmetry	SYM	45	-	55	%	50% V _{CC} level
0 Level Output Voltage	V _{OL}	-	-	V _{CC} ×0.1	V	
1 Level Output Voltage	V _{OH}	V _{CC} ×0.9	-	-	V	
Rise and Fall Time	t _r ,t _f	-	-	7.5	ns	L _{CMOS} : 30pF 20 to 80% V _{CC} level
Start Up Time	T _{start}	-	-	1	ms	t=0 at 90% V _{CC}
Phase Noise	-	-	-139	-	dBc/Hz	Offset 1kHz
		-	-156	-		Offset 100kHz
Period Jitter (1)	t _{RMS}	-	2.4	-	ps	σ
	t _{p-p}	-	20	-		Peak to peak
Total Jitter (1)	t _{TL}	-	34	-		t _{DJ} +n×t _{RJ} n=14.1 (BER=1×10 ⁻¹²) (2)
Phase Jitter (3)	t _{pj}	-	-	1		10MHz≤f ₀ <54MHz f ₀ offset 12kHz to 5MHz
						40MHz≤f ₀ ≤60MHz f ₀ offset 12kHz to 20MHz
Built-in Bypass Capacitors Capacitance	C _{bp}	-	0.1	-	μF	V _{CC} to GND capacitance

- (1) Measured WAVECREST DTS-2075
 (2) t_{DJ}: Deterministic jitter t_{RJ}: Random jitter
 (3) Measured Keysight Technologies E5052B

Consult our sales representative for other specifications.

*Moisture prevention packing is unnecessary. Moisture Sensitivity Level : Level 1 (IPC/JEDEC J-STD-033)

Dimensions

[mm]

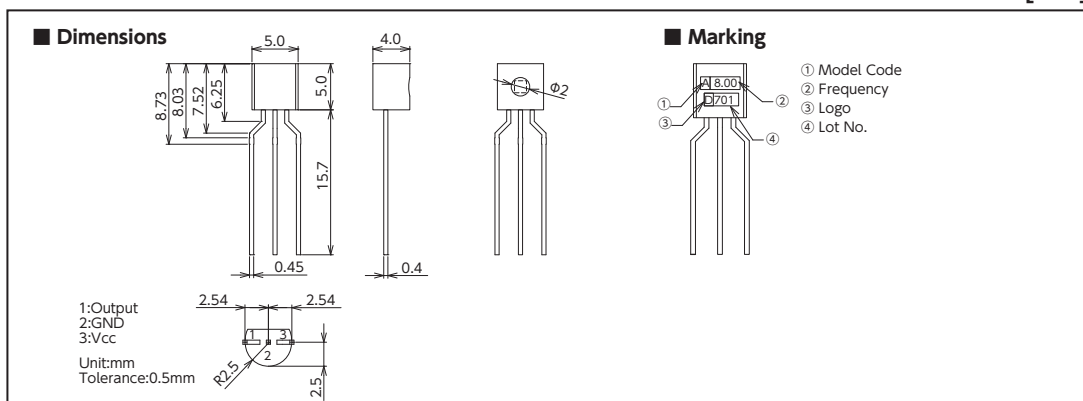

SMD Voltage Controlled Crystal Oscillators

DSV221SV/DSV321SV

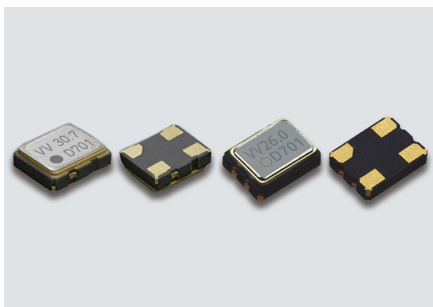

■ Features

- DSV221SV: 2520 size, 0.8 mm height
DSV321SV: 3225 size, 1.1mm height
- The product is an analog VCXO which ensures good variable frequency and a linear changing frequency.
- Low current consumption
- CMOS Level Output

■ Applications

- DVD, Digital TV, STB, backbone transmission equipment



Actual size DSV221SV DSV321SV

■ Standard Specification

Item	Type	Legend	DSV221SV	DSV321SV
Output Frequency Range		f_0	30.72MHz	6.75 to 125MHz
Supply Voltage		V_{cc}	$+3.3V \pm 0.33V$	
Frequency Control Voltage		V_{cont}	$+1.65V \pm 1.65V$	
Storage Temperature Range		T_{stg}	-40 to $+85^\circ C$	
Operating Temperature Range		T_{use}	-30 to $+85^\circ C$	-10 to $+70^\circ C$ / -30 to $+85^\circ C$
Frequency Tolerance (Includes frequency tolerance at room temperature.)		f_{tol}	$\pm 40 \times 10^{-6}$ max.	
Frequency Adjustment Range		f_{cont}	$\pm 100 \times 10^{-6}$ min. [Positive Slope]	
Current Consumption		I_{cc}	7mA max. [No Load]	7mA max. ($6.75MHz \leq f_0 \leq 36MHz$) 17mA max. ($36MHz < f_0 \leq 70MHz$) 27mA max. ($70MHz < f_0 \leq 125MHz$) [No Load]
Load Condition		L_{CMOS}	15pF	
Symmetry		SYM	40 to 60% [50% V_{cc} Level]	
0 Level Output Voltage		V_{OL}	$V_{cc} \times 0.1$ max.	
1 Level Output Voltage		V_{OH}	$V_{cc} \times 0.9$ min.	
Rise and Fall Time		t_r, t_f	5ns max. [10 to 90% V_{cc} Level]	5ns max. ($6.75MHz \leq f_0 \leq 90MHz$) 3ns max. ($90MHz < f_0 \leq 125MHz$) [10 to 90% V_{cc} Level]
Period Jitter (1)		t_{RMS}	2.4ps typ. (σ)	
		t_{p-p}	22ps typ. (Peak to peak)	
Total Jitter (1)		t_{TL}	33ps typ. [$t_{DJ} + n \times t_{RJ}$ $n=14.1$ ($BER=1 \times 10^{-12}$) (2)]	
Phase Jitter		t_{pj}	1ps max. ($10MHz \leq f_0 < 40MHz$, f_0 offset : 12kHz to 5MHz, $f_0 \geq 40MHz$, f_0 offset : 12kHz to 20MHz)	
Packing Unit (3)		-	2000pcs./reel ($\phi 180$)	

(1) Measured WAVECREST DTS-2075

(2) t_{DJ} : Deterministic jitter t_{RJ} : Random jitter

(3) Moisture prevention packing is unnecessary.
Moisture Sensitivity Level : Level 1 (IPC/JEDEC J-STD-033)

Consult our sales representative for other specifications.

■ DSV221SV

[mm]

■ DSV321SV

[mm]

■ Dimensions

Model Code: VV 27.0 D 701

Pin Connections

Pin No.	Connection
#1	V_{cont}
#2	GND
#3	Output
#4	V_{cc}

■ Recommended Land Pattern <Top View>

■ Dimensions

Model Code: VV 27.0 D 701

Pin Connections

Pin No.	Connection
#1	V_{cont}
#2	GND
#3	Output
#4	V_{cc}

■ Recommended Land Pattern <Top View>

Quartz Devices

For Automotive



SMD Crystal Resonators / MHz Band Crystal Resonators (For Automotive)

DSX1210A

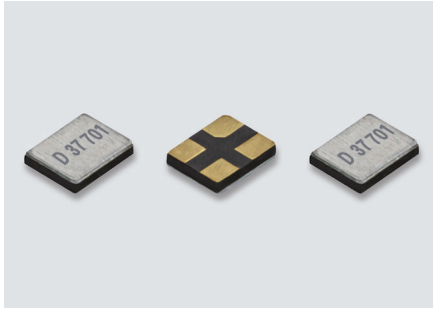

Actual size □

■ Features

- 1210 size ultra miniature and lightweight SMD crystal resonator with a low profile of 0.28mm
- High precision and high reliability
(Frequency aging specification of $\pm 1 \times 10^{-6}$ /1 year or $\pm 3 \times 10^{-6}$ /5 years is available for cell phone or wireless communication systems etc.)
- Allowing for high density surface mounting.
- AEC-Q200 Compliant



■ Applications

- Automotive wireless applications such as Bluetooth, wireless LAN, etc.

■ Standard Specification

Item	Type	DSX1210A			
		32MHz	37.4MHz / 38.4MHz / 40MHz	48MHz/52MHz	76.8MHz/80MHz
Frequency Range		32MHz	37.4MHz / 38.4MHz / 40MHz	48MHz/52MHz	76.8MHz/80MHz
Overtone Order		Fundamental			
Load Capacitance		8pF, 10pF, 12pF			
Drive Level		10μW (100μW max.)			
Frequency Tolerance		$\pm 10 \times 10^{-6}$, $\pm 20 \times 10^{-6}$ (at 25°C)			
Series Resistance		100Ω max.	60Ω max.	40Ω max.	30Ω max.
Frequency Characteristics over Temperature		$\pm 30 \times 10^{-6}$ / -40 to +105°C (Ref. To 25°C)			
Storage Temperature Range		-40 to +125°C			
Reliability		AEC-Q200			
Packing Unit (1)		3000pcs./reel(φ180)			

(1) Moisture prevention packing is unnecessary.
Moisture Sensitivity Level: LEVEL1 (IPC/JEDEC J-STD-033)

Consult our sales representative for other specifications.

[mm]

■ Dimensions

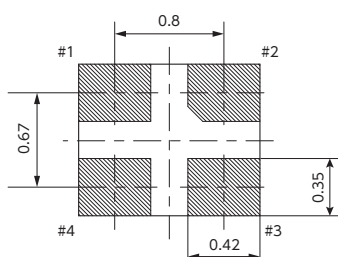
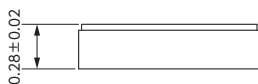
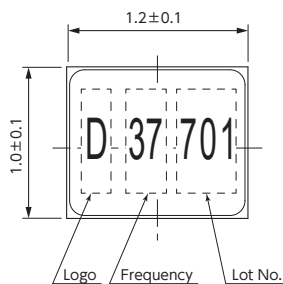

■ Internal Connections

(Top View)

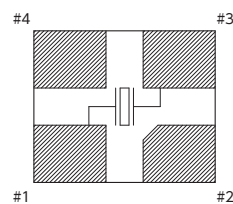

1 & # 3 connected to quartz element
2 & # 4 connected to the cover

■ Recommended Land Pattern

(Top View)

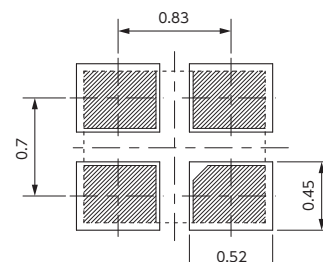

SMD Crystal Resonators / MHz Band Crystal Resonators (For Automotive)

DSX1612S

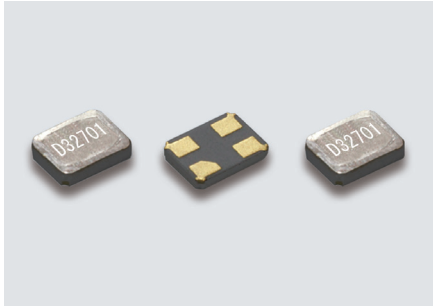

Actual size □

■ Features

- 1612 size ultra miniature and lightweight SMD crystal resonator with a low profile of 0.35 mm.
- High precision and high reliability (Frequency aging specification of $\pm 1 \times 10^{-6}$ /1 year or $\pm 3 \times 10^{-6}$ /5 years is available for cell phone or wireless communication systems etc.)
- Allowing for high density surface mounting.
- AEC-Q200 Compliant



■ Applications

- Bluetooth, wireless LAN, GPS/GNSS and other automotive wireless, multimedia devices, etc.

■ Standard Specification

Item	Type	DSX1612S		
		24 to 32MHz	32 to 40MHz	40 to 54MHz
Frequency Range		24 to 32MHz	32 to 40MHz	40 to 54MHz
Overtone Order		Fundamental		
Load Capacitance		8pF, 10pF, 12pF		
Drive Level		10μW (100μW max.)		
Frequency Tolerance		$\pm 10 \times 10^{-6}$, $\pm 20 \times 10^{-6}$ (at 25°C)		
Series Resistance		100Ω max.	50Ω max.	
Frequency Characteristics over Temperature		$\pm 30 \times 10^{-6}$ / -40 to +125°C (Ref. To 25°C)		
Storage Temperature Range		-40 to +125°C		
Reliability		AEC-Q200		
Packing Unit (1)		3000pcs./reel(φ180)		

(1) Moisture prevention packing is unnecessary.
Moisture Sensitivity Level: LEVEL1 (IPC/JEDEC J-STD-033)

Consult our sales representative for other specifications.

[mm]

■ Dimensions

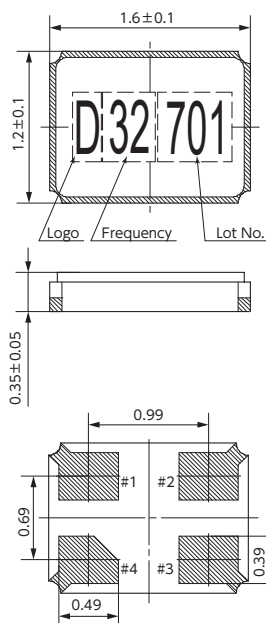

■ Internal Connections

〈Top View〉

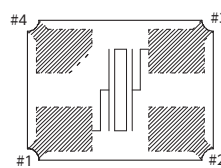

- # 1 & # 3 connected to quartz element
- # 2 connected to the cover
- # 4 open (unconnected)
- # 2 & # 4 recommended GND connection

■ Recommended Land Pattern

〈Top View〉

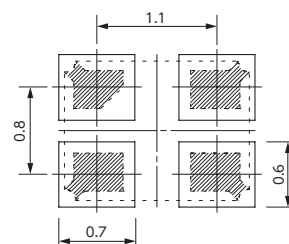

SMD Crystal Resonators / MHz Band Crystal Resonators (For Automotive)

DSX211G/DSX210GE

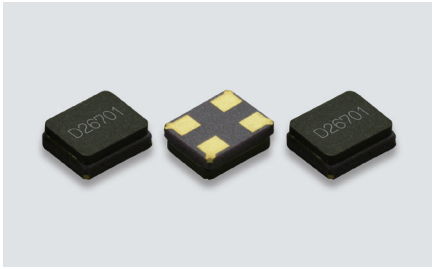

DSX211G

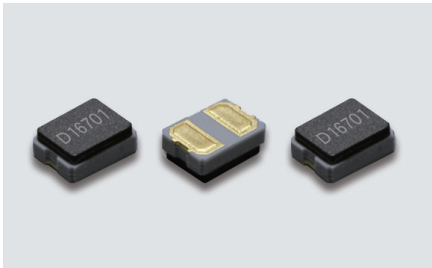

DSX210GE

Actual size

■ Features

- Miniature and lightweight SMD crystal resonator (height DSX211G 0.65mm / DSX210GE 0.85mm)
- Excellent heat resistance, High precision and high reliability
- Offers a wide range of frequencies from 16MHz to 64MHz
- Enhanced durability of solder joint for thermal cycles : after 3000 Thermal cycle tests $-40, +125^{\circ}\text{C}$ (DSX210GE)
- AEC-Q200 Compliant

■ Applications

- Automotive radio applications such as Bluetooth, wireless LAN, GPS/GNSS, multimedia devices and automotive camera
- ECU (engine, body work control), safety relations, car body controls, ABS, EPS (DSX210GE)

■ Standard Specification

Item	Type	DSX210GE				
		DSX211G				
Frequency Range		16 to 20MHz	20 to 24MHz	24 to 30MHz	30 to 36MHz	36 to 64MHz
Overtone Order		Fundamental				
Load Capacitance		8pF, 10pF, 12pF				
Drive Level		10 μW (100 μW max.)				
Frequency Tolerance		$\pm 30 \times 10^{-6}$ (at 25 $^{\circ}\text{C}$)				
Series Resistance		400 Ω max.	200 Ω max.	150 Ω max.	120 Ω max.	80 Ω max.
Frequency Characteristics over Temperature		$\pm 100 \times 10^{-6} / -40$ to $+125^{\circ}\text{C}$ (Ref. to 25 $^{\circ}\text{C}$)				
Storage Temperature Range		-40 to $+150^{\circ}\text{C}$				
Reliability		AEC-Q200				
Packing Unit (1)		3000pcs./reel($\phi 180$)				

(1) Moisture prevention packing is unnecessary.
Moisture Sensitivity Level: LEVEL1 (IPC/JEDEC J-STD-033)

Consult our sales representative for other specifications.

■ DSX211G

[mm]

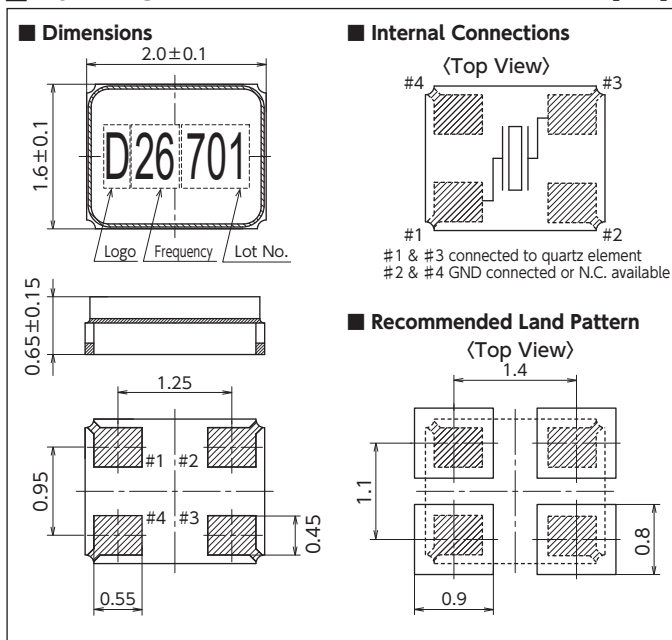

■ DSX210GE

[mm]

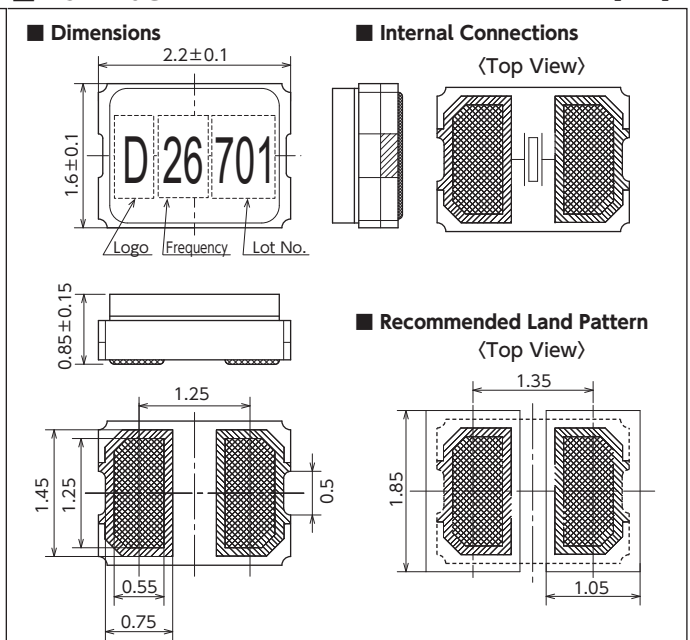

SMD Crystal Resonators / MHz Band Crystal Resonators (For Automotive)

DSX321G/DSX321GK/DSX320GE



DSX321G/DSX321GK

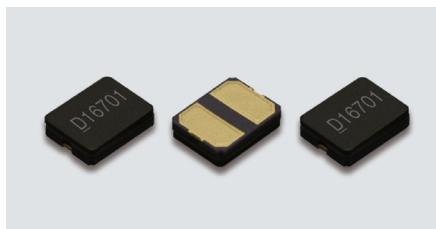

DSX320GE

Actual size

■ Features

- Miniature and lightweight SMD crystal resonator height DSX321G (over 12MHz): 0.75mm (12MHz or under): 0.85mm DSX321GK: 0.85mm DSX320GE: 0.95mm
- Excellent heat resistance, High precision and high reliability
- Offers a wide range of frequencies DSX321G/DSX320GE: 7.9 to 64MHz DSX321GK: 9.8 to 40MHz
- Enhanced durability of solder joint for thermal cycles : after 3000 thermal cycle tests "-40, +125°C" (DSX320GE)
- AEC-Q200 Compliant



RoHS/ELV Compliant

■ Applications

- RKE (Remote Keyless Entry), TPMS and safety controls (DSX321GK)
- Multimedia devices such as car navigation systems and car audio (DSX321G)
- ECU (engine, body work control), safety relations, car body controls, ABS, EPS (DSX320GE)

■ Standard Specification

Item	Type	DSX321G/DSX320GE					
		DSX321GK					
Frequency Range		7.9 to 9.8MHz	9.8 to 11MHz	11 to 12MHz	12 to 27MHz	27 to 40MHz	40 to 64MHz
Overtone Order		Fundamental					
Load Capacitance		8pF, 10pF, 12pF					
Drive Level		10μW(200μW max.)					
Frequency Tolerance		±30×10 ⁻⁶ (at 25°C)					
Series Resistance		400Ω max.	200Ω max.	150Ω max.	120Ω max.	100Ω max.	
Frequency Characteristics over Temperature		±100×10 ⁻⁶ /-40 to +125°C(Ref. to 25°C)					
Storage Temperature Range		-40 to +150°C					
Reliability		AEC-Q200					
Packing Unit (1)		3000pcs./reel(φ180)					

(1) Moisture prevention packing is unnecessary.
Moisture Sensitivity Level:LEVEL1 (IPC/JEDEC J-STD-033)

Consult our sales representative for other specifications.

■ DSX321G/DSX321GK

[mm]

■ DSX320GE

[mm]

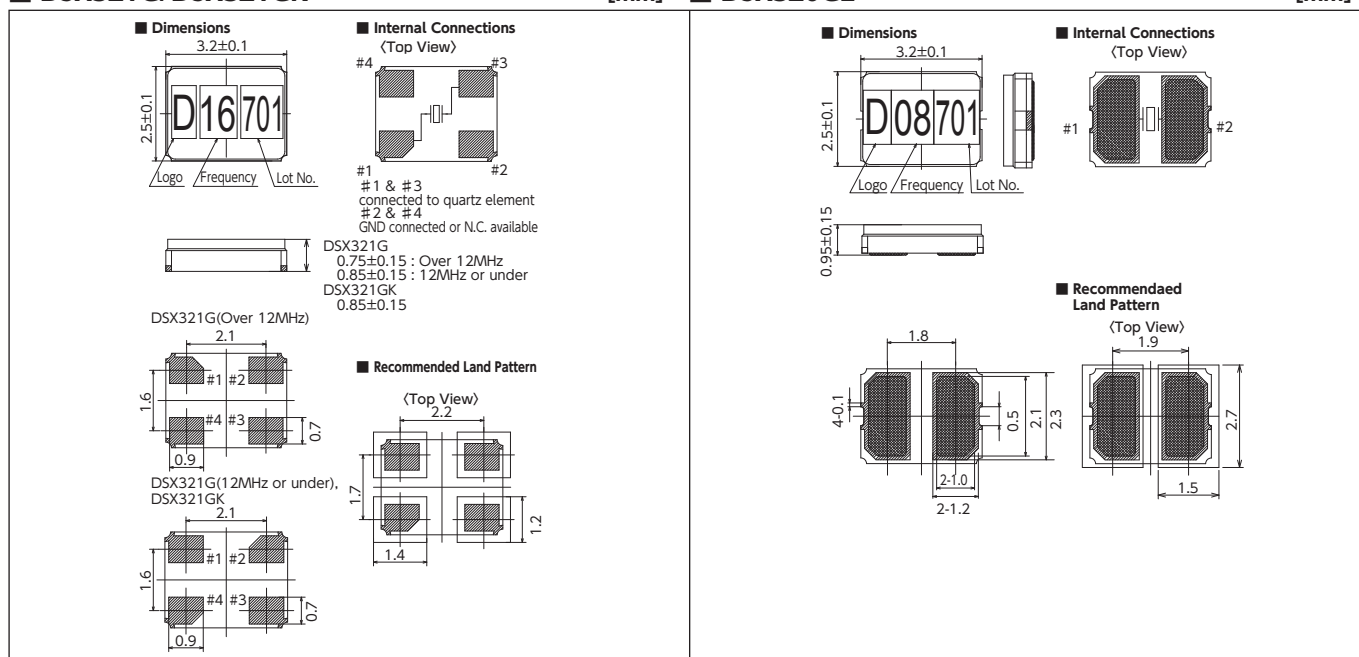

SMD Crystal Resonators / MHz Band Crystal Resonators (For Automotive)

DSX530GA

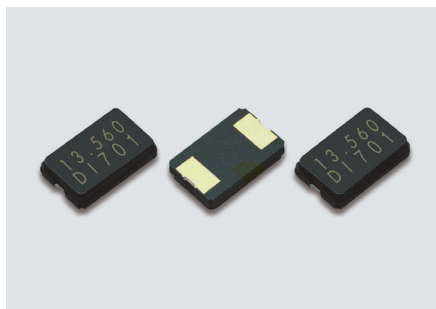

Actual size

■ Features

- Miniature and low profile SMD crystal resonator (height 1.0mm)
- Excellent heat resistance, High reliability.
- AEC-Q200 Compliant



RoHS/ELV Compliant

■ Applications

- Multimedia devices such as car navigation systems and car audio

■ Standard Specification

Item	Type	DSX530GA
Frequency Range		7 to 8MHz
Overtone Order		Fundamental
Load Capacitance		8pF, 10pF, 12pF
Drive Level		10 μ W (300 μ W max.)
Frequency Tolerance		$\pm 30 \times 10^{-6}$ (at 25°C)
Series Resistance		200 Ω max.
Frequency Characteristics over Temperature		$\pm 100 \times 10^{-6}$ / -40 to +125°C (Ref. to 25°C)
Storage Temperature Range		-40 to +150°C
Reliability		AEC-Q200
Packing Unit (1)		1000pcs./reel ($\phi 180$)

(1) Moisture prevention packing is unnecessary.
Moisture Sensitivity Level: LEVEL1 (IPC/JEDEC J-STD-033)

Consult our sales representative for other specifications.

■ DSX530GK/DSX530GA

[mm]

■ Dimensions

■ Internal Connections

⟨Top View⟩

■ Recommended Land Pattern

⟨Top View⟩

SMD Crystal Resonators / MHz Band Crystal Resonators (For Automotive)

DSX211SH/DSX221SH/DSX321SH

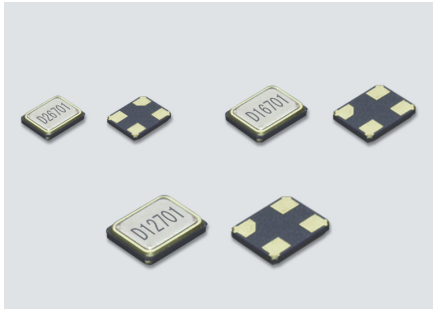

Actual size DSX211SH □ DSX221SH □
DSX321SH □

■ Features

- Miniature and lightweight SMD crystal resonator
DSX211SH : 2016 size 0.45mm height
DSX221SH : 2520 size 0.45mm height
DSX321SH : 3225 size 0.65mm height
- Excellent heat resistance, High precision and high reliability
- Offers a wide range of frequencies
DSX211SH : 16MHz to 60MHz
DSX221SH : 12MHz to 54MHz
DSX321SH : 12MHz to 50MHz
- AEC-Q200 Compliant



■ Applications

- Automotive radio applications such as Bluetooth, wireless LAN and GPS/GNSS and multimedia devices, etc.

■ Standard Specification

Item	Type	DSX211SH		DSX221SH			DSX321SH			
		16 to 30MHz	30 to 60MHz	12 to 24MHz	24 to 30MHz	30 to 54MHz	12 to 20MHz	20 to 32MHz	32 to 50MHz	
Frequency Range		16 to 30MHz	30 to 60MHz	12 to 24MHz	24 to 30MHz	30 to 54MHz	12 to 20MHz	20 to 32MHz	32 to 50MHz	
Overtone Order		Fundamental								
Load Capacitance		8pF, 10pF, 12pF								
Drive Level		10μW (100μW max.)			10μW (200μW max.)					
Frequency Tolerance		±30×10 ⁻⁶ (at 25°C)								
Series Resistance		100Ω max.	50Ω max.	120Ω max.	50Ω max.	40Ω max.	80Ω max.	50Ω max.	40Ω max.	
Frequency Characteristics over Temperature		±100×10 ⁻⁶ / -40 to +125°C (Ref. to 25°C)								
Storage Temperature Range		-40 to +150°C								
Reliability		AEC-Q200								
Packing Unit (1)		3000pcs./reel(φ180)								

(1) Moisture prevention packing is unnecessary.
Moisture Sensitivity Level: LEVEL1 (IPC/JEDEC J-STD-033)

Consult our sales representative for other specifications.

■ DSX211SH

[mm]

■ DSX221SH

[mm]

■ DSX321SH

[mm]

■ Dimensions	■ Dimensions	■ Dimensions
■ Internal Connections (Top View) <p>#1 & #3 connected to quartz element #2 & #4 connected to the cover #2 & #4 recommended GND connection</p>	■ Internal Connections (Top View) <p>#1 & #3 connected to quartz element #2 & #4 connected to the cover #2 & #4 recommended GND connection</p>	■ Internal Connections (Top View) <p>#1 & #3 connected to quartz element #2 & #4 connected to the cover #2 & #4 recommended GND connection</p>
■ Recommended Land Pattern (Top View) 	■ Recommended Land Pattern (Top View) 	■ Recommended Land Pattern (Top View)

SMD Crystal Resonators with dedicated temperature sensor / MHz Band Crystal Resonators (For Automotive)

DSR1612ATH/DSR211STH/DSR221STH

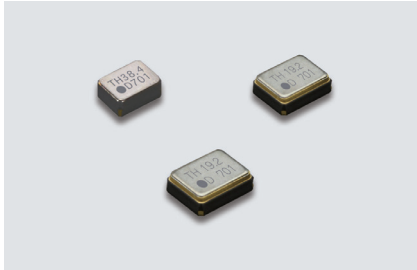

Actual size DSR1612ATH □ DSR211STH □
DSR221STH □

Features

- DSR1612ATH: 1612size, height 0.55mm
DSR211STH: 2016size, height 0.7mm (19.2MHz)
0.6mm (38.4MHz / 55.2MHz)
- DSR221STH: 2520size, height 0.9mm
- Built-in NTC thermistor
- AEC-Q200 Compliant

Applications

- Multimedia devices such as car navigation systems and car audio
- GPS/GNSS
- UWB



Standard Specification

Item	Type	DSR1612ATH	DSR211STH	DSR221STH
Frequency Range		38.4Mhz	19.2MHz / 38.4MHz / 55.2MHz	19.2MHz
Overtone Order		Fundamental		
Load Capacitance		7pF, 8pF		
Drive Level		10μW (100μW max.)		
Frequency Tolerance		±10×10 ⁻⁶ (at 25°C)		
Series Resistance		80Ω max.		
Frequency Characteristics over Temperature		±30×10 ⁻⁶ / -40 to +105 °C (±12×10 ⁻⁶ / -30 to +85 °C)		±30×10 ⁻⁶ / -40 to +105 °C (±12×10 ⁻⁶ / -30 to +85 °C) ±20×10 ⁻⁶ / -40 to +105 °C
Storage Temperature Range		-40 to +125 °C		
Thermistor Resistance		10kΩ / 100kΩ (at +25°C)		
Thermistor B-constant		3435K (+25 to +85°C) / 3380K / 4250K (+25 to +50°C)		
Reliability		AEC-Q200		
Packing Unit (1)		3000pcs./reel (φ180)		

(1) Moisture prevention packing is unnecessary.
Moisture Sensitivity Level : LEVEL 1 (IPC/JEDEC J-STD-033)

Consult our sales representative for other specifications.

DSR1612ATH [mm]	DSR211STH [mm]	DSR221STH [mm]
<h4>Dimensions</h4> <p>ModelCode: TH38.4, D701 Frequency: 38.4MHz Dimensions: 1.64±0.06, 1.24±0.06, 0.55±0.1, 1.10, 0.70, 0.84, 0.30, 0.10</p> <h4>Internal Connections</h4> <p>(Top View) #4 SENSOR, #3 X1tal, #1 X1tal, #2 GND</p> <h4>Recommended Land Pattern</h4> <p>(Top View) Dimensions: 1.80, 0.55, 0.70, 1.80, 1.40, 0.30, 0.55, 1.10, 0.84</p>	<h4>Dimensions</h4> <p>Model Code: TH19.2, D701 Frequency: 19.2MHz / 38.4MHz / 55.2MHz Dimensions: 2.0±0.1, 1.6±0.1, 0.7±0.1, 1.375, 0.975, 0.475, 0.15, 0.75</p> <h4>Internal Connections</h4> <p>(Top View) #4 SENSOR, #3 X1tal, #1 X1tal, #2 GND</p> <h4>Recommended Land Pattern</h4> <p>(Top View) Dimensions: 2.20, 0.75, 0.75, 1.375, 1.80, 0.45, 0.20</p>	<h4>Dimensions</h4> <p>Model Code: TH19.2, D701 Frequency: 19.2MHz Dimensions: 2.5±0.15, 2.0±0.15, 0.9±0.1, 1.75, 1.65, 0.65, 1.55, 0.85, 0.95</p> <h4>Internal Connections</h4> <p>(Top View) #4 SENSOR, #3 X1tal, #1 X1tal, #2 GND</p> <h4>Recommended Land Pattern</h4> <p>(Top View) Dimensions: 1.95, 0.95, 1.55, 0.85, 1.80, 1.15</p>

SMD Tuning Fork Crystal Resonators / kHz Band Crystal Resonators (For Automotive)

DST1610A/DST210AC/DST310SA

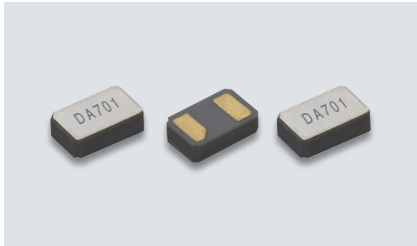

DST1610A

Actual size □

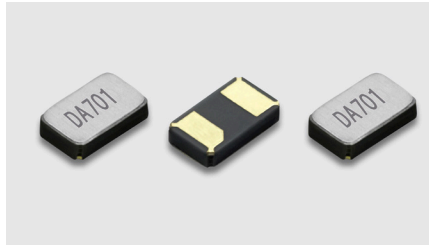

DST210AC

Actual size □

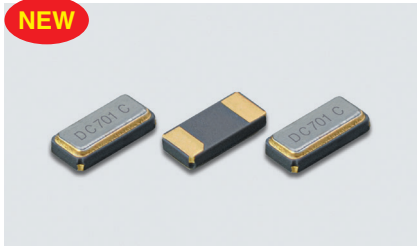

DST310SA

Actual size □

■ Features

- AEC-Q200 Compliant
- Pb free
- RoHS/ELV Compliant

■ Applications

- Automotive multimedia devices



■ Standard Specification

Item	Type	DST1610A	DST210AC	DST310SA
Frequency Range		32.768kHz		
Load Capacitance		7pF, 9pF, 12.5pF		
Drive Level		0.1μW (0.5μW max.)		
Frequency Tolerance		±20×10 ⁻⁶ (at 25°C)		
Series Resistance		50kΩ max. (-40 to +85°C) 80kΩ max. (-40 to +125°C)	80kΩ max. (-40 to +85°C) 120kΩ max. (-40 to +125°C)	50kΩ max. (-40 to +85°C) 80kΩ max. (-40 to +125°C)
Turnover Temperature		+25°C±5°C		
Parabolic Coefficient		-0.04×10 ⁻⁶ / °C ² max.		
Operating Temperature Range		-40 to +85°C / -40 to +125°C		
Storage Temperature Range		-40 to +125°C		-55 to +125°C
Shunt Capacitance		1.6pF typ.	1.3pF typ.	1.7pF typ.
Reliability		AEC-Q200		
Packing Unit (1)		3000pcs./reel(φ180)		

(1) Moisture prevention packing is unnecessary.
Moisture Sensitivity Level: Level 1 (IPC/JEDEC J-STD-033)

Consult our sales representative for other specifications.

■ DST1610A [mm]		■ DST210AC [mm]		■ DST310SA [mm]	
■ Dimensions 	■ Internal Connections (Top View) 	■ Dimensions 	■ Internal Connections (Top View) 	■ Dimensions 	■ Internal Connections (Top View)
■ Recommended Land Pattern (Top View) 	■ Recommended Land Pattern (Top View) 	■ Recommended Land Pattern (Top View) 	■ Recommended Land Pattern (Top View) 	■ Recommended Land Pattern (Top View) 	■ Recommended Land Pattern (Top View)

SMD Crystal Oscillators (For Automotive)

DSO221SHH

NEW

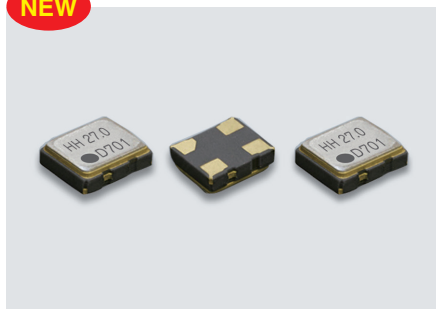

Actual size

Features

- Supply Voltage: 1.8V/2.5V/2.8V/3.3V
- Low phase noise : Offset 1kHz -146dBc/Hz(typ.)
: Offset 100kHz -164dBc/Hz(typ.)
- Available frequency range: 2.0 to 54MHz
- Low profile : 0.8 mm
- 3-state function
- CMOS Level Output
- AEC-Q200 Compliant (Option: Equivalent to AEC-Q100)

Applications

- Automotive multimedia device



[Function Code]

DSO221SHH A A

- A : 3.3V
- B : 2.8V
- C : 2.5V
- D : 1.8V

When requesting the product, please select the model and function code of your request.

Standard Specification

Reliability	Function Code		Output Frequency Range (MHz)	Legend	Spec.				Condition
	Supply Voltage	Frequency tolerance			min.	typ.	max.	Unit	
Supply Voltage	A	*	2.0≤f _o ≤54	V _{cc}	+3.0	+3.3	+3.6	V	
	B				+2.6	+2.8	+3.0		
	C				+2.25	+2.5	+2.75		
	D				+1.62	+1.8	+2.0		
Frequency Tolerance (Includes frequency tolerance at room temperature.)	*	A	*	f _{tol}	-100	-	+100	×10 ⁻⁶	-40 to +125°C
		B			-50	-	+50		-40 to +85°C
		C			-30	-	+30		-20 to +70°C
Current Consumption	A	*	2.0≤f _o ≤54	I _{cc}	-	-	4.2	mA	No Load
	B				-	-	2.3		
	C				-	-	-		
	D				-	-	-		
Stand-by Current(#1 pin "L" Level)	*	*	*	I _{std}	-	-	10	μA	
Symmetry	*	*	*	SYM	40	50	60	%	50% V _{cc} Level
0 Level Output Voltage	*	*	*	V _{OL}	-	-	V _{cc} ×0.1	V	
1 Level Output Voltage	*	*	*	V _{OH}	V _{cc} ×0.9	-	-	V	
Rise and Fall Time	A, B, C	*	*	tr, tf	-	-	4	ns	10 to 90% V _{cc} Level
	D				-	-	6.5		
Load Condition	*	*	*	L _{CMOS}	-	-	15	pF	
OE Pin 0 Level Input Voltage	*	*	*	V _L	-	-	V _{cc} ×0.2	V	
OE Pin 1 Level Input Voltage	*	*	*	V _H	V _{cc} ×0.8	-	-	V	
Output Disable Time	*	*	*	tPZL	-	-	100	ns	
Output Enable Time	*	*	*	tPZL	-	-	2	ms	
Phase Noise	*	*	*	-	-	-146	-	dBc/Hz	Offset 1kHz
					-	-164	-		Offset 100kHz
Period Jitter (1)	*	*	*	tRMS	-	2.4	-	ps	σ
				tp-p	-	23	-		Peak to peak
Total Jitter (1)	*	*	*	tTL	-	34	-	ps	tDJ+n×tRJ n=14.1(BER=1×10 ⁻¹³) (2)
Phase Jitter	*	*	40≤f _o ≤54	tpj	-	-	1	ps	f _o offset:12kHz to 20MHz
			10≤f _o <40						f _o offset:12kHz to 5MHz
Reliability	AEC -Q100/AEC-Q200								
Packing Unit(3)	3000pcs./reel(φ180)								

(1) Measured WAVECREST DTS-2075

Consult our sales representative for other specifications.

(2) tDJ:Deterministic jitter tRJ:Random jitter

(3) Moisture prevention packing is unnecessary.

Moisture Sensitivity Level: LEVEL 1 (IPC/JEDEC J-STD-033)

[mm]

Dimensions

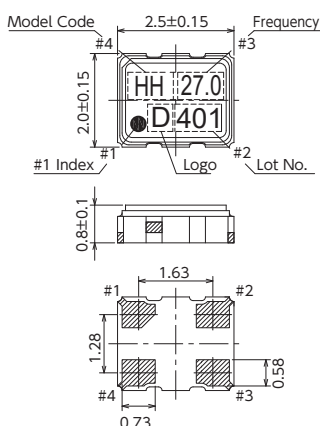

Pin Connections

Pin No.	Connection
#1	OE(Output Enable)
#2	GND
#3	Output
#4	V _{cc}

Function	#3 Output condition
H	Oscillation out
Open	Oscillation out
L	High Z

Recommended Land Pattern

<Top View>

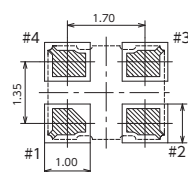

SMD Crystal Oscillators (For Automotive)

DSO1612AR

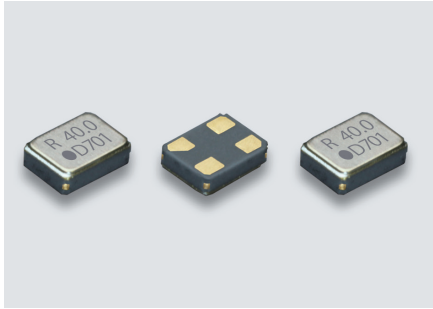

Actual size □

■ Features

- 3-state function
- Capable of operating over a wide temperature range, from -40 to $+125^{\circ}\text{C}$.
- AEC-Q200 Compliant (Option: Equivalent to AEC-Q100)
- CMOS Level Output

■ Applications

- Multimedia devices such as car navigation systems and car audio
- Automotive camera

[Function Code]

DSO1612AR A Y

A : 3.3V
M : 3.0V
B : 2.8V
C : 2.5V
D : 1.8V

Y : $\pm 100 \times 10^{-6}$
Z : $\pm 80 \times 10^{-6}$
B : $\pm 50 \times 10^{-6}$



■ Standard Specification

When requesting the product, please select the model and function code of your request.

Item	Function Code		Legend	Output Frequency Range (MHz)	Spec.			Unit	Condition	
	Supply Voltage	Frequency tolerance			min.	typ.	max.			
Supply Voltage	A	*	Vcc	0.584375 ≤ fo ≤ 80	+3.0	+3.3	+3.6	V		
	M				+2.7	+3.0	+3.3			
	B				+2.6	+2.8	+3.0			
	C				+2.25	+2.5	+2.75			
Frequency Tolerance (Includes frequency tolerance at room temperature.)	*	Y	f_tol	0.584375 ≤ fo ≤ 80	-100	-	+100	10 ⁻⁶	-40 to +125°C	
		Z			-80	-	+80		-40 to +110°C	
		B			-50	-	+50		-40 to +85°C	
Current Consumption	A,M	*	Icc	0.584375 ≤ fo < 40	-	-	+3.0	mA	No Load	
				40 ≤ fo < 80	-	-	+4.2			
	B			0.584375 ≤ fo < 40	-	-	+2.4			
				40 ≤ fo ≤ 80	-	-	+3.7			
	C			0.584375 ≤ fo < 40	-	-	+2.0			
				40 ≤ fo ≤ 80	-	-	+3.4			
D	0.584375 ≤ fo < 40	-	-	+1.7						
40 ≤ fo ≤ 80	-	-	+2.7							
Stand-by Current (#1 pin "L" level)	*	*	I_std	*	-	-	+20	μA		
Load Condition	*	*	L_CMOS	*	-	-	15	pF		
Symmetry	*	*	SYM	*	40	50	60	%	at 50% Vcc	
0 Level Output Voltage	*	*	Vol	*	-	-	Vcc × 0.1	V		
1 Level Output Voltage	*	*	Voh	*	Vcc × 0.9	-	-	V		
Rise and Fall Time	A,M,B,C	*	tr, tf	*	-	-	3.0	ns	10 to 90% Vcc Level	
	D				-	-	5			
OE Pin 0 Level Input Voltage	*	*	VIL	*	-	-	Vcc × 0.2	V		
OE Pin 1 Level Input Voltage	*	*	VIH	*	Vcc × 0.8	-	-	V		
Output Disable Time	*	*	tPLZ	*	-	-	200	ns		
Output Enable Time	*	*	tPZL	*	-	-	2	ms		
Period Jitter (1)	*	*	tRMS	*	-	2.2	-	ps	σ	
			tp-p	*	-	20	-	ps	Peak to peak	
Total Jitter (1)	*	*	tTL	*	-	31	-	ps	tDJ+n×tRJ n=14.1 (BER=1×10 ⁻¹³) (2)	
Phase Jitter	*	*	tpj	*	40 ≤ fo ≤ 80	-	-	1	ps	fo offset: 12kHz to 20MHz
Reliability	AEC-Q100/AEC-Q200									
Packing Unit (3)	3000pcs./reel (φ 180)									

- (1) Measured WAVECREST DTS-2075
- (2) tDJ: Deterministic jitter tRJ: Random jitter
- (3) Moisture prevention packing is unnecessary. Moisture Sensitivity Level: Level 1 (IPC/JEDEC J-STD-033)

Consult our sales representative for other specifications.

[mm]

■ Dimensions

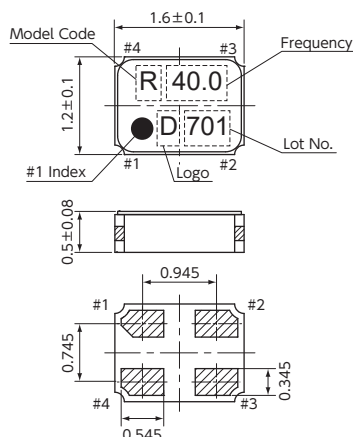

■ Recommended Land Pattern

Pin Connections	
Pin No.	Connection
#1	OE (Output Enable)
#2	GND
#3	Output
#4	Vcc

Function	
#1 Input	#3 Output condition
H	Oscillation out
Open	Oscillation out
L	High Z

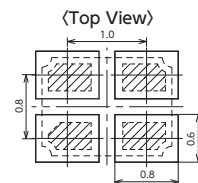

SMD Crystal Oscillators (For Automotive)

DSO221SR/DSO321SR

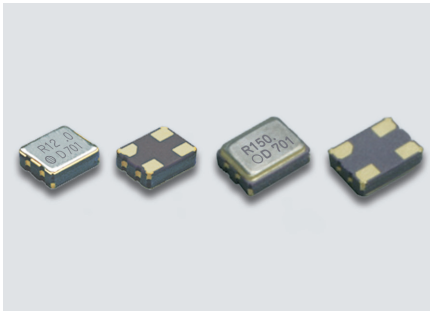

Actual size DSO221SR □ DSO321SR □

Features

- 3-state function
- Capable of operating over a wide temperature range, from -40 to +125°C.
- AEC-Q200 Compliant (Option: Equivalent to AEC-Q100)
- CMOS Level Output

Applications

- Multimedia devices such as car navigation systems and car audio
- Automotive camera

[Type]

DSO221SR	2520 size
DSO321SR	3225 size

[Function Code]

DSO***SR A A

A : 3.3V	$\begin{matrix} \uparrow \\ \uparrow \\ \uparrow \\ \uparrow \end{matrix}$	A, Y : $\pm 100 \times 10^{-6}$
M : 3.0V		Z : $\pm 80 \times 10^{-6}$
B : 2.8V		B : $\pm 50 \times 10^{-6}$
C : 2.5V		
D : 1.8V		



Standard Specification

When requesting the product, please select the model and function code of your request.

Item	Function Code		Output Frequency Range (MHz)	Legend	Spec.				Condition
	Supply Voltage	Frequency tolerance			min.	typ.	max.	Unit	
Supply Voltage	A	*	$0.2 \leq f_0 \leq 125$	V _{CC}	+3.0	+3.3	+3.6	V	
	M		$0.2 \leq f_0 \leq 125$		+2.7	+3.0	+3.3		
	B		$0.2 \leq f_0 \leq 100$		+2.6	+2.8	+3.0		
	C		$0.2 \leq f_0 \leq 100$		+2.25	+2.5	+2.75		
	D		$0.2 \leq f_0 \leq 80$		+1.6	+1.8	+2.0		
Frequency Tolerance (Includes frequency tolerance at room temperature.)	*	Y	$0.2 \leq f_0 \leq 100$	f _{tol}	-100	-	+100	×10 ⁻⁶	-40 to +125°C
		Z	$0.2 \leq f_0 \leq 100$		-80	-	+80		-40 to +110°C
		A	$100 < f_0 \leq 125$		-100	-	+100		
		B	$0.2 \leq f_0 \leq 100$		-50	-	+50		-40 to +85°C
Current Consumption	A, M	*	$0.2 \leq f_0 < 54$	I _{CC}	-	-	+4.0	mA	No Load
			$54 \leq f_0 < 80$		-	-	+6.0		
			$80 \leq f_0 \leq 125$		-	-	+8.0		
	B	*	$0.2 \leq f_0 < 54$		-	-	+3.5		
			$54 \leq f_0 < 80$		-	-	+5.5		
			$80 \leq f_0 \leq 100$		-	-	+7.5		
	C	*	$0.2 \leq f_0 < 54$		-	-	+3.0		
			$54 \leq f_0 < 80$		-	-	+5.0		
			$80 \leq f_0 \leq 100$		-	-	+7.0		
	D	*	$0.2 \leq f_0 < 54$		-	-	+2.5		
			$54 \leq f_0 < 80$		-	-	+4.5		
					-	-			
Stand-by Current (#1 pin 'L' level)	*	*	*	L _{std}	-	-	+10	μA	
Load Condition	*	*	*	L _{CMOS}	-	-	15	pF	
Symmetry	*	*	*	SYM	40	50	60	%	50% V _{CC} Level
0 Level Output Voltage	*	*	*	V _{OL}	-	-	V _{CC} × 0.1	V	
1 Level Output Voltage	*	*	*	V _{OH}	V _{CC} × 0.9	-	-	V	
Rise and Fall Time	*	*	$0.2 \leq f_0 \leq 54$	tr,tf	-	-	8	ns	10 to 90% V _{CC} Level
			$54 < f_0 < 100$		-	-	4		
			$100 \leq f_0 \leq 125$		-	-	3		
OE Pin 0 Level Input Voltage	*	*	*	V _{IL}	-	-	V _{CC} × 0.2	V	
OE Pin 1 Level Input Voltage	*	*	*	V _{IH}	V _{CC} × 0.8	-	-	V	
Output Disable Time	*	*	*	t _{PZL}	-	-	150	ns	
Output Enable Time	*	*	*	t _{PZL}	-	-	5	ms	
Period Jitter (1)	*	*	*	t _{RMS}	-	2.2	-	ps	σ
Total Jitter (1)	*	*	*	tp-p	-	20	-	ps	Peak to peak
Phase Jitter	*	*	*	t _{TL}	-	31	-	ps	f ₀ offset: 12kHz to 20MHz
Reliability	AEC-Q100/AEC-Q200								
Packing Unit (3)	2000pcs./reel(180 φ)								

- (1) Measured WAVECREST DTS-2075
- (2) t_{DJ}:Deterministic jitter t_{RJ}:Random jitter
- (3) Moisture prevention packing is unnecessary. Moisture Sensitivity Level:Level 1 (IPC/JEDEC J-STD-033)

Consult our sales representative for other specifications.

DSO221SR

[mm]

DSO321SR

[mm]

Dimensions

Pin No.	Connection
#1	OE(Output Enable)
#2	GND
#3	Output
#4	V _{CC}

Function	#1 Input	#3 Output condition
H	Oscillation out	Oscillation out
Open	Oscillation out	Oscillation out
L	High Z	High Z

Dimensions

Pin No.	Connection
#1	OE(Output Enable)
#2	GND
#3	Output
#4	V _{CC}

Function	#1 Input	#3 Output condition
H	Oscillation out	Oscillation out
Open	Oscillation out	Oscillation out
L	High Z	High Z

SMD Crystal Oscillators (For Automotive)

DSO211SX/DSO221SX

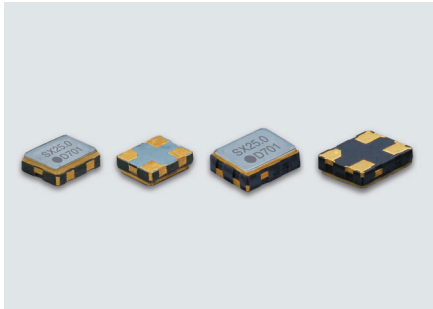

Actual size DSO211SX DSO221SX

Features

- Supply Voltage: 1.8V/2.5V/2.8V/3.3V
- Available frequency range: 1 to 125MHz
- Low profile: 0.7mm (DSO211SX), 0.8mm (DSO221SX)
- CMOS Level Output
- Capable of operating over a wide temperature range, from -40 to 125°C.
- 3-state function
- Conforms to Autonomous Driving Level II
- AEC-Q100/AEC-Q200 Compliant



Applications

- In-vehicle driving safety applications (millimeter-wave radar, sensing cameras, etc.)

[Type]

DSO211SX	2016 size
DSO221SX	2520 size

[Function Code]

DSO***SX	A Z	
A : 3.3V	↑	A : $\pm 100 \times 10^{-6}$
B : 2.8V	↑	Z : $\pm 80 \times 10^{-6}$
C : 2.5V	↑	B : $\pm 50 \times 10^{-6}$
D : 1.8V	↑	C : $\pm 30 \times 10^{-6}$

When requesting the product, please select the model and function code of your request.

Standard Specification

Item	Function Code		Output Frequency Range (MHz)	Legend	Spec.			Unit	Condition
	Supply Voltage	Frequency tolerance			min.	typ.	max.		
Supply Voltage	A	*	$1 \leq f_0 \leq 125$	VCC	+3.0	+3.3	+3.6	V	
	B				+2.6	+2.8	+3.0		
	C		+2.25		+2.5	+2.75			
	D		+1.6		+1.8	+2.0			
Frequency Tolerance (includes frequency tolerance at room temperature)	A	*	*	f_tol	-	-	± 100	$\times 10^{-6}$	-40 to +125°C
	B				-	-	± 80		-40 to +85°C
	C				-	-	± 50		
Current Consumption	A	*	$1 \leq f_0 < 40$	I_cc	-	-	2.4	mA	No Load
			$40 \leq f_0 < 100$		-	-	4.2		
			$100 \leq f_0 \leq 125$		-	-	10.0		
			$1 \leq f_0 < 40$		-	-	2.2		
			$40 \leq f_0 < 100$		-	-	3.7		
			$100 \leq f_0 \leq 125$		-	-	9.0		
	B		$1 \leq f_0 < 40$		-	-	2.0		
			$40 \leq f_0 < 100$		-	-	3.4		
			$100 \leq f_0 \leq 125$		-	-	8.0		
	C		$1 \leq f_0 < 40$		-	-	1.7		
			$40 \leq f_0 < 100$		-	-	2.7		
			$100 \leq f_0 \leq 125$		-	-	2.7		
Stand-by Current (#1 pin "L" level)	*	*	*	I_std	-	-	10	μ A	
Load Condition	*	*	*	L_CMOS	-	-	15	pF	
Symmetry	*	*	*	SYM	45	50	55	%	50% Vcc Level
0 Level Output Voltage	*	*	*	VOL	-	-	$V_{cc} \times 0.1$	V	
1 Level Output Voltage	*	*	*	VOH	$V_{cc} \times 0.9$	-	-	V	
Rise and Fall Time	A,B,C	*	*	tr, tf	-	-	3	ns	10 to 90% Vcc Level
	D				-	-	5		
OE Pin 0 Level Input Voltage	*	*	*	V _{IL}	-	-	$V_{cc} \times 0.3$	V	
OE Pin 1 Level Input Voltage	*	*	*	V _{IH}	$V_{cc} \times 0.7$	-	-	V	
Output Disable Time	*	*	*	tPLZ	-	-	200	ns	
Output Enable Time	*	*	*	tPZL	-	-	2	ms	
Period Jitter (1)	*	*	*	tRMS	-	2.4	-	ps	σ
Total Jitter (1)	*	*	*	tp-p	-	23	-	ps	Peak to peak
Phase Jitter	*	*	$40 \leq f_0 \leq 125$	tpj	-	-	1	ps	tDJ+n×tRJ n=14.1 (BER=1×10 ⁻¹²) (2)
			$10 \leq f_0 < 40$		f ₀ offset: 12kHz to 20MHz f ₀ offset: 1.2kHz to 5MHz				
Reliability	AEC-Q100/AEC-Q200								
Packing Unit (3)	3000pcs./reel (φ 180)								

(1) Measured WAVECREST DTS-2075

Consult our sales representative for other specifications.

(2) tDJ:Deterministic jitter tRJ:Random jitter

(3) Moisture prevention packing is unnecessary. Moisture Sensitivity Level:Level1 (IPC/JEDEC J-STD-033)

DSO211SX

[mm]

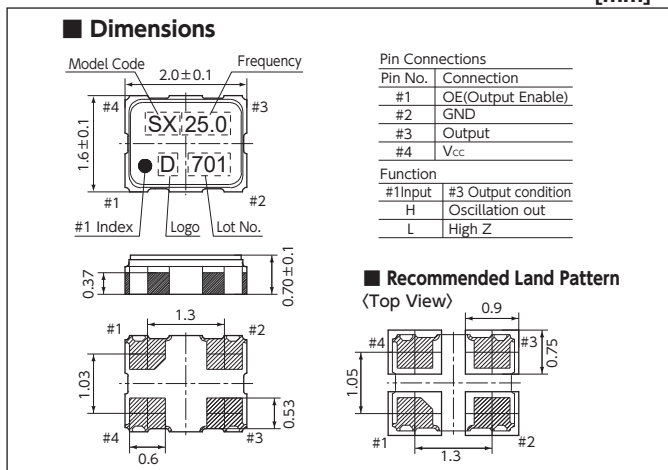

DSO221SX

[mm]

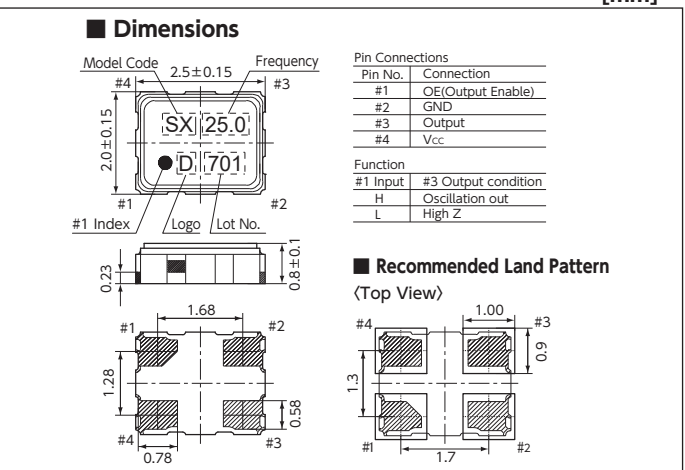

SMD Crystal Oscillators (For Automotive)

DSO221SR/DSO321SR (kHz)

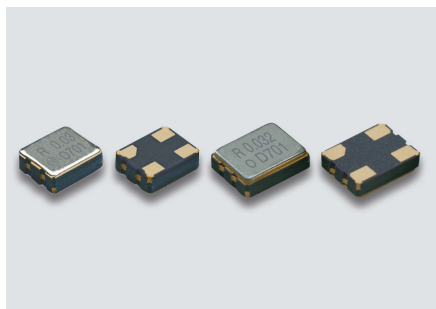

Actual size DSO221SR DSO321SR

■ Features

- Supply Voltage: 1.8V/2.5V/2.8V/3.0V/3.3V/5.0V
- 3-state function
- Low current consumption
- CMOS Level Output
- High speed start-up: 2ms max. until frequency output after power on
- Stable frequency variation realized by adopting an At cut resonator
- AEC-Q200 Compliant (Option: Equivalent to AEC-Q100)

■ Applications

- Multimedia devices such as car navigation systems and car audio



[Function Code]

DSO***SR

A : 3.3V
M : 3.0V
B : 2.8V
C : 2.5V
D : 1.8V
Y : 5.0V

Y: ±100 × 10⁻⁶
Z: ±80 × 10⁻⁶
B, W: ±50 × 10⁻⁶

[Type]

DSO221SR	2520 size
DSO321SR	3225 size

■ Standard Specification

When requesting the product, please select the model and function code of your request.

Item	Function Code		Output Frequency Range (KHz)	Legend	Spec.			Unit	Condition
	Supply Voltage	Frequency tolerance			min.	typ.	max.		
Supply Voltage	A	*	32.768 ≤ f ₀ ≤ 50	V _{cc}	+3.0	+3.3	+3.6	V	
	M				+2.7	+3.0	+3.3		
	B				+2.6	+2.8	+3.0		
	C				+2.25	+2.5	+2.75		
	D				+1.6	+1.8	+2.0		
	Y				+4.5	+5.0	+5.5		
Frequency Tolerance (includes frequency tolerance at room temperature)	*	Y	32.768 ≤ f ₀ ≤ 50	f _{tol}	-100	-	+100	× 10 ⁻⁶	-40 to +125°C
	*	Z			-80	-	+80		-40 to +110°C
	*	W			-50	-	+50		-40 to +105°C
	*	B			-50	-	+50		-40 to +85°C
Current Consumption	A, M, B, C, D	*	f ₀ =32.768	I _{cc}	-	-	65	μA	No Load
	Y		32.768 < f ₀ ≤ 50		-	-	100		
			f ₀ =32.768		-	-	80		
			32.768 < f ₀ ≤ 50		-	-	120		
Stand-by Current (#1 pin "L" Level)	*	*	32.768 ≤ f ₀ ≤ 50	I _{std}	-	-	3	μA	-40 to +125°C
Load Condition	*	*	32.768 ≤ f ₀ ≤ 50	L _{CMOS}	-	-	15	pF	
Symmetry	*	*	32.768 ≤ f ₀ ≤ 50	SYM	45	50	55	%	at 50% V _{cc}
0 Level Output Voltage	*	*	*	V _{OL}	-	-	V _{cc} × 0.1	V	
1 Level Output Voltage	*	*	*	V _{OH}	V _{cc} × 0.9	-	-		
Rise and Fall Time	*	*	32.768 ≤ f ₀ ≤ 50	t _r , t _f	-	-	20	ns	10 to 90% V _{cc} Level
OE Pin 0 Level Input Voltage	*	*	*	V _{IL}	-	-	V _{cc} × 0.2	V	
OE Pin 1 Level Input Voltage	*	*	*	V _{IH}	V _{cc} × 0.8	-	-		
Output Disable Time	*	*	*	t _{PLZ}	-	-	150	ns	
Output Enable Time	*	*	*	t _{PZL}	-	-	2	ms	
Period Jitter (1)	*	*	*	t _{RMS}	-	15	-	ps	σ
				t _{p-p}	-	150	-		Peak to peak
Total Jitter (1)	*	*	*	t _L	-	220	-	ps	t _{DJ} +n×t _{RJ} n=14.1 (BER=1×10 ⁻¹²) (2)
Reliability	AEC-Q100/AEC-Q200								
Packing Unit (3)	2000pcs./reel (φ180)								

- (1) Measured WAVECREST DTS-2075
- (2) t_{DJ}:Deterministic jitter t_{RJ}:Random jitter
- (3) Moisture prevention packing is unnecessary. Moisture Sensitivity Level:Level 1 (IPC/JEDEC J-STD-033)

Consult our sales representative for other specifications.

■ DSO221SR(kHz)

■ DSO321SR(kHz)

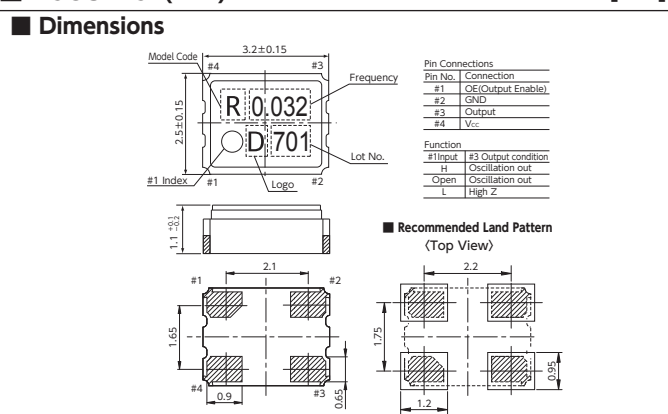
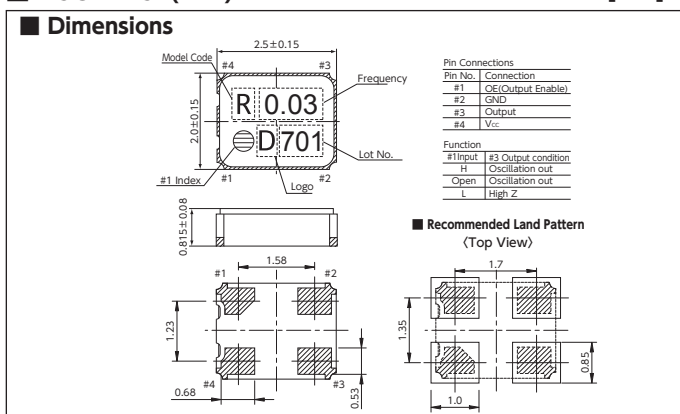

SMD Crystal Oscillators (For Automotive)

DSO221SY/DSO321SY

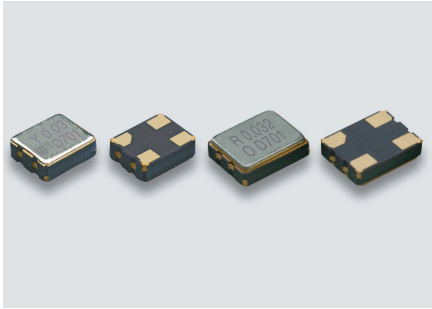

Actual size DSO221SY □ DSO321SY □

■ Features

- Available frequency range : 32.768kHz, 1.049 to 8.5MHz
- Supply Voltage: 1.8V/2.5V/2.8V/3.3V
- 3-state function
- Low current consumption: 10μA typ.(32.768kHz)
- CMOS Level Output
- Stable frequency variation realized by adopting an At cut resonator
- AEC-Q200 Compliant (Option: Equivalent to AEC-Q100)



■ Applications

- Multimedia devices such as car navigation systems and car audio

[Type]

DSO221SY	2520 size
DSO321SY	3225 size

[Function Code]

DSO***SY A A

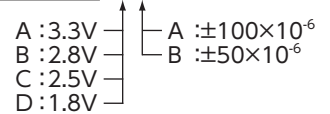

When requesting the product, please select the model and function code of your request.

■ Standard Specification

Item	Function Code		Output Frequency Range	Legend	Spec.				Condition
	Supply Voltage	Frequency tolerance			min.	typ.	max.	Unit	
Supply Voltage	A	*	32.768kHz 1.049 ≤ f _o ≤ 8.5MHz	V _{cc}	+3.0	+3.3	+3.6	V	
	B				+2.6	+2.8	+3.0		
	C				+2.25	+2.5	+2.75		
	D				+1.6	+1.8	+2.0		
Frequency Tolerance (includes frequency tolerance at room temperature)	*	A	32.768kHz 1.049 ≤ f _o ≤ 8.5MHz	f _{tol}	-100	-	+100	× 10 ⁻⁶	-40 to +85°C
		B			-50	-	+50		
Current Consumption	*	*	32.768kHz 1.049 ≤ f _o ≤ 8.5MHz	I _{cc}	-	-	18 700	μA	No Load
Stand-by Current (#1 pin "L" Level)	*	*	*	I _{std}	-	-	3	μA	
Load Condition	*	*	*	L _{CMOS}	-	-	15	pF	
Symmetry	*	*	32.768kHz 1.049 ≤ f _o ≤ 8.5MHz	SYM	45 40	50 50	55 60	%	at 50% V _{cc}
0 Level Output Voltage	*	*	*	V _{OL}	-	-	V _{cc} × 0.1	V	
1 Level Output Voltage	*	*	*	V _{OH}	V _{cc} × 0.9	-	-	V	
Rise and Fall Time	*	*	*	tr, tf	-	-	15	ns	10 to 90% V _{cc} Level
OE Pin 0 Level Input Voltage	*	*	*	V _{IL}	-	-	V _{cc} × 0.2	V	
OE Pin 1 Level Input Voltage	*	*	*	V _{IH}	V _{cc} × 0.8	-	-	V	
Output Disable Time	*	*	*	t _{PLZ}	-	-	100	ns	
Output Enable Time	*	*	*	t _{PZL}	-	-	20	ms	
Reliability	AEC-Q100/AEC-Q200								
Packing Unit (1)	2000pcs./reel (φ 180)								

(1) Moisture prevention packing is unnecessary.
Moisture Sensitivity Level: Level 1 (IPC/JEDEC J-STD-033)

Consult our sales representative for other specifications.

■ DSO221SY

■ DSO321SY

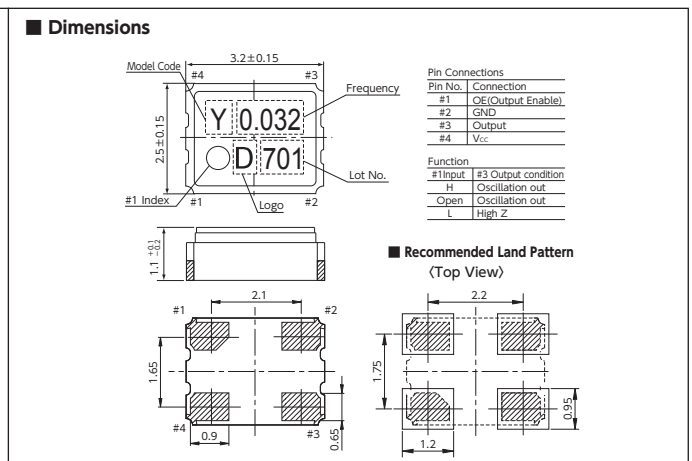
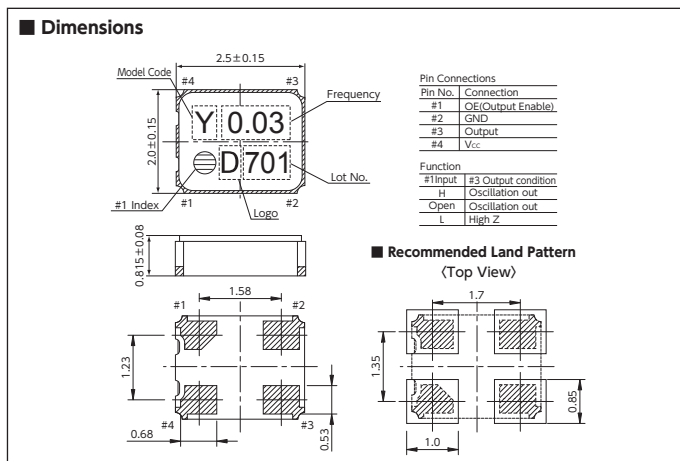

SMD Differential Output Crystal Oscillators (For Automotive)

DSO223SK/DSO323SK/DSO223SJ/DSO323SJ/DSO223SD/DSO323SD

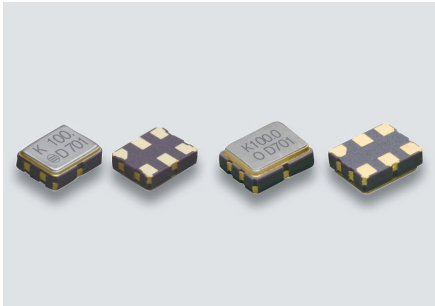

Actual size DSO223S DSO323S

■ Features

- 2.5V/3.3V operating voltage, High speed type
- 3-state function
- LV-PECL output (DSO223/323SK)
- LVDS output (DSO223/323SJ)
- HCSL output (DSO223/323SD)
- AEC Standard
- DSO223SK/SJ/SD: AEC-Q200 Compliant
- DSO323SK/SJ/SD: AEC-Q200 Compliant (Option: Equivalent to AEC-Q100)

■ Applications

- Multimedia devices such as car navigation systems and car audio

[Type]

DSO223S SERIES	2520 size
DSO323S SERIES	3225 size



[Function Code]

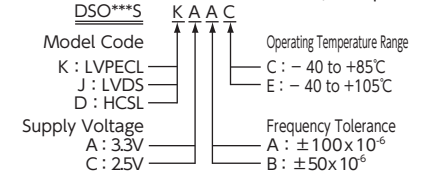

When requesting the product, please select the model and function code of your request.

■ Standard Specification

Item	Type	Legend	DSO223SK DSO323SK	DSO223SJ DSO323SJ	DSO223SD DSO323SD
Output Specification	—	—	LV-PECL	LVDS	HCSL
Output Frequency Range	f _o	—	13.5 to 167MHz		
Supply Voltage	V _{CC}	—	+2.5V±0.125V/+3.3V±0.165V		
Frequency Tolerance (Includes frequency tolerance at room temperature.)	f _{tol}	—	±50×10 ⁻⁶ max., ±80×10 ⁻⁶ max. / ±100×10 ⁻⁶ max.		
Storage Temperature Range	T _{stg}	—	-40 to +105°C		
Operating Temperature Range	T _{use}	—	-40 to +85°C, -40 to +105°C		
Current Consumption	I _{CC}	—	45mA max.	20mA max.	30mA max.
Stand-by Current (#1 pin "L" Level)	I _{std}	—	10μA max.		
Load Resistance	Load-R	—	50Ω to V _{CC} -2V	100Ω (Output-OutputN)	50Ω
Symmetry	SYM	—	45 to 55% [at outputs cross point]		
0 Level Output Voltage	V _{OL}	—	V _{CC} -1.81 to V _{CC} -1.62V	—	-0.15 to 0.15V
1 Level Output Voltage	V _{OH}	—	V _{CC} -1.025 to V _{CC} -0.88V	—	0.58 to 0.85V
Rise and Fall Time	tr, tf	—	0.5ns max. [20 to 80% Output, OutputN]	0.4ns max. [20 to 80% Output-OutputN]	0.5ns max. [0.175 to 0.525V Level]
Differential Output Voltage	V _{OD1} , V _{OD2}	—	—	0.247 to 0.454V	—
Change to V _{OD}	ΔV _{OD}	—	—	50mV [ΔV _{OD} = V _{OD1} -V _{OD2}]	—
Offset Voltage	V _{OS}	—	—	1.125 to 1.375V	—
Offset to V _{OS}	ΔV _{OS}	—	—	50mV	—
Crossing Point Voltage	V _{CR}	—	—	—	250 to 550mV
OE Pin 0 Level input Voltage	V _{IL}	—	V _{CC} ×0.3 max.		
OE Pin 1 Level input Voltage	V _{IH}	—	V _{CC} ×0.7 min.		
Output Disable Time	t _{PLZ}	—	200ns		
Output Enable Time	t _{PZL}	—	2ms		
Period Jitter (1)	t _{RMS}	—	5ps typ. (13.5MHz≤f _o <27MHz) / 2.5ps typ. (27MHz≤f _o ≤167MHz) (σ)		
	tp-p	—	33ps typ. (13.5MHz≤f _o <27MHz) / 22ps typ. (27MHz≤f _o ≤167MHz) (Peak to peak)		
Total Jitter (1)	t _{TL}	—	50ps typ. (13.5MHz≤f _o <27MHz) / 35ps typ. (27MHz≤f _o ≤167MHz) [t _{DJ} + n×t _{RJ} n=14.1(BER=1×10 ⁻¹²) (2)]		
Phase Jitter	tpj	—	1.5ps max. (13.5MHz≤f _o <27MHz) / 1ps max. (27MHz≤f _o ≤167MHz) [13.5MHz≤f _o <40MHz, f _o offset: 1.2kHz to 5MHz f _o ≥40MHz, f _o offset: 1.2kHz to 20MHz]		
Reliability	—	—	AEC-Q200(DSO223 SERIES), AEC-Q100/AEC-Q200(DSO323 SERIES)		
Packing Unit (3)	—	—	2000pcs./reel(φ180)		

- (1) Measured WAVECREST DTS-2075
- (2) t_{DJ}:Deterministic jitter t_{RJ}:Random jitter
- (3) Moisture prevention packing is unnecessary.
Moisture Sensitivity Level: LEVEL 1 (IPC/JEDEC J-STD-033)

Consult our sales representative for other specifications.

■ DSO223S SERIES

■ DSO323S SERIES

■ Dimensions

Model Code: DSO223SJ: J, DSO223SK(2.5V): KB, DSO223SK(3.3V): K, DSO223SD: D

Pin Connections:

Pin No.	Connection
#1	OE(Output Enable)
#2	NC
#3	GND
#4	Output
#5	OutputN
#6	V _{CC}

Function: #1 Input, #4,#5 Output condition, H Oscillation out, Open Oscillation out, L High Z

■ Recommended Land Pattern

<Top View>

■ Dimensions

Model Code: DSO323SJ, DSO323SK(2.5V): KB, DSO323SK(3.3V): K, DSO323SD

Pin Connections:

Pin No.	Connection
#1	OE(Output Enable)
#2	NC
#3	GND
#4	Output
#5	OutputN
#6	V _{CC}

Function: #1 Input, #4,#5 Output condition, H Oscillation out, Open Oscillation out, L High Z

■ Recommended Land Pattern

<Top View>

SMD Differential Output Crystal Oscillators - Low Voltage (For Automotive)

DSO323SJ/DSO323SD

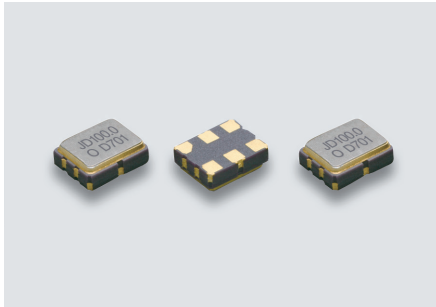

Actual size

Features

- 1.8V operating voltage, High speed type
- 3-state function
- LVDS output (DSO323SJ)
- HCSL output (DSO323SD)
- AEC-Q200 Compliant (Option: Equivalent to AEC-Q100)

Applications

- Multimedia devices such as car navigation systems and car audio

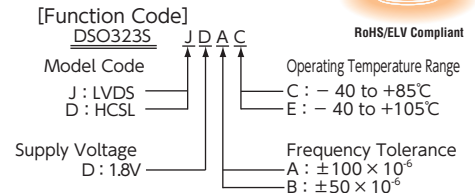

When requesting the product, please select the model and function code of your request.

Standard Specification

Item	Type	Legend	DSO323SJ	DSO323SD
Output Specification	—		LVDS	HCSL
Output Frequency Range	f _o		100 to 167MHz	
Supply Voltage	V _{cc}		+1.8V±0.09V	
Frequency Tolerance (Includes frequency tolerance at room temperature.)	f _{tol}		±50×10 ⁻⁶ max., ±80×10 ⁻⁶ max. / ±100×10 ⁻⁶ max.	
Storage Temperature Range	T _{stg}		-40 to +105°C	
Operating Temperature Range	T _{use}		-40 to +85°C, -40 to +105°C	
Current Consumption	I _{cc}		25mA max.	50mA max.
Stand-by Current (#1 pin "L" Level)	I _{std}		30μA max.	
Load Resistance	Load-R		100Ω (Output-OutputN)	50Ω
Symmetry	SYM		45 to 55% [at outputs cross point]	
0 Level Output Voltage	V _{OL}		—	-0.15 to 0.15V
1 Level Output Voltage	V _{OH}		—	0.55 to 1.0V
Rise and Fall Time	tr, tf		0.4ns max. [20 to 80% Output-OutputN]	0.5ns max. [-0.15 to 0.15V/Output-OutputN]
Differential Output Voltage	V _{OD1} , V _{OD2}		0.247 to 0.454V	—
Change to V _{OD}	ΔV _{OD}		50mV [ΔV _{OD} = V _{OD1} - V _{OD2}]	—
Offset Voltage	V _{OS}		1.125 to 1.375V	—
Offset to V _{OS}	ΔV _{OS}		50mV	—
OE Pin 0 Level input Voltage	V _{IL}		V _{cc} ×0.3 max.	
OE Pin 1 Level input Voltage	V _{IH}		V _{cc} ×0.7 min.	
Output Disable Time	t _{PLZ}		200ns	
Output Enable Time	t _{PZL}		2ms	
Period Jitter (1)	t _{RMS}		2.5ps typ. (σ)	
	tp-p		22ps typ. (Peak to peak)	
Total Jitter (1)	t _{TL}		35ps typ. [t _{DJ} + n×t _{RJ} n=14.1 (BER=1×10 ⁻¹²) (2)]	
Phase Jitter	tpj		0.15ps max.	
Reliability			AEC-Q100/AEC-Q200	
Packing Unit (3)			2000pcs./reel (φ180)	

- (1) Measured WAVECREST DTS-2075
- (2) t_{DJ}:Deterministic jitter t_{RJ}:Random jitter
- (3) Moisture prevention packing is unnecessary.
Moisture Sensitivity Level: LEVEL 1 (IPC/JEDEC J-STD-033)

Consult our sales representative for other specifications.

DSO323S SERIES

[mm]

Dimensions

Model Code
 DSO323S-J/D
 DSO323SD-DD

Pin Connections

Pin No.	Connection
#1	OE(Output Enable)
#2	NC
#3	GND
#4	Output
#5	OutputN
#6	Vcc

Function

#1 Input	#4,#5 Output condition
H	Oscillation out
Open	Oscillation out
L	High Z

Recommended Land Pattern

<Top View>

High-precision SMD VC-TCXO/TCXO (For Automotive)

DSA211SP/DSB211SP

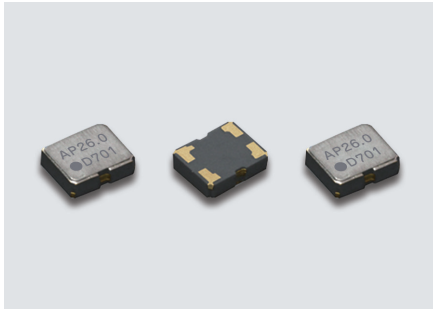

Actual size

■ Features

- Capable of operating over a wide temperature range, from -40 to +105°C
- Low voltage operation
- Low phase noise
- Single packaged structure
- AEC-Q100/AEC-Q200 compliant

■ Applications

- GPS / GNSS
- Telematics, Satellite radio



■ Standard Specification

Item	Type	DSA211SP(VC-TCXO)	DSB211SP(TCXO)
Output Frequency Range		12.288 to 52 MHz	12.288 to 52 MHz
Standard Frequency		16.3676/ 16.367667/ 16.368/ 16.369/ 16.8/ 26/ 38.4 MHz	
Supply Voltage Range		+1.68 to +3.5V	
Supply Voltage (Vcc)		+1.8V / +2.8 V / +3.0V / +3.3V	
Current Consumption		+1.7 mA max. (f≤26MHz)/+2.2 mA max. (f>26MHz)	
Output Level		0.8 Vp-p min. (Clipped Sine Wave / DC-coupled)	
Output Load		10 kΩ//10 pF	
Frequency Stability Tolerance		±1.5×10 ⁻⁶ max.(After 2 reflows)	
vs. Temperature		±1.0×10 ⁻⁶ max. / -40 to +105°C	±0.5×10 ⁻⁶ max. / -40 to +105°C
vs. Supply Voltage		±0.2×10 ⁻⁶ max. (Vcc±5%)	
vs. Load Variation		±0.2×10 ⁻⁶ max.	
vs. Aging		±1.0×10 ⁻⁶ max. /year	
Start up Time		2.0ms max.	
Frequency Control Control Sensitivity		±3.0×10 ⁻⁶ to ±5.0×10 ⁻⁶ / Vcont=+1.4V±1V @Vcc≥+2.6V ±3.0×10 ⁻⁶ to ±5.0×10 ⁻⁶ / Vcont=+0.9V±0.6V @Vcc=+1.8V	—
Response Slope		Positive	—
SSB Phase Noise		[f≤15MHz]	[15MHz<f≤26MHz]
Offset 100Hz		-115 dBc/Hz	-110 dBc/Hz
Offset 1kHz		-135 dBc/Hz	-130 dBc/Hz
Offset 10kHz		-145 dBc/Hz	-140 dBc/Hz
Offset 100kHz		-145 dBc/Hz	-145 dBc/Hz
Reliability		AEC-Q100/AEC-Q200	
Packing Unit (1)		3000pcs./reel (φ180)	

(1) Prevention of moisture packing is unnecessary
Moisture Sensitivity Level : LEVEL 1 (IPC/JEDEC J-STD-033)

Consult our sales representative for other specifications.

[mm]

■ Dimensions

Model Code
AP : VC-TCXO (DSA211SP)
BP : TCXO (DSB211SP)

Pin Connections

Pin No.	Connection
#1	Vcont(VC-TCXO)/GND(TCXO)
#2	GND
#3	Output
#4	Vcc

■ Recommended Land Pattern (Top View)

High-precision SMD TCXO (For Automotive)

DSB1612SEB

NEW

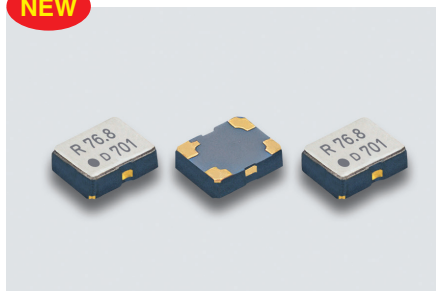

Actual size □

Features

- Capable of operating over a wide temperature range from -40 to +105°C
- High frequencies operation
- Low voltage operation
- Clipped sine wave
- Low phase noise
- Single package structure
- AEC-Q200 Compliant



Applications

- Automotive WiFi, WiLAN, WiMAX, Bluetooth
- GNSS, Industrial equipment

Standard Specification

		DSB1612SEB	
Output Frequency Range		26 to 76.8MHz	
Supply Voltage Range		+1.8 to +3.3V	
Current Consumption		+4.5mA max.(f≤52MHz)/+5.0mA max.(f>52MHz)	
Stand-by Current (#1 pin "L" Level)		+3uA max.	
Output Level		0.8Vp-p min. (Clipped Sine Wave / DC-coupled)	
Output Load		10kΩ//10pF	
Frequency Stability		±2.0×10 ⁻⁶ max.(After 2 reflows)	
Tolerance			
vs. Temperature		±5.0×10 ⁻⁶ max. (-40 to +105°C)	±0.5×10 ⁻⁶ max. (-40 to +85°C)
vs. Supply Voltage		±0.2×10 ⁻⁶ max. (Vcc±5%)	
vs. Load Variation		±0.2×10 ⁻⁶ max.	
vs. Aging		±2.0×10 ⁻⁶ max./year	
Start up Time		2.0ms max.	
Phase Noise		[f≤52MHz]	[f>52MHz]
Offset 100Hz		-110dBc/Hz	-108dBc/Hz
Offset 1kHz		-130dBc/Hz	-125dBc/Hz
Offset 10kHz		-152dBc/Hz	-150dBc/Hz
Offset 100kHz		-155dBc/Hz	-155dBc/Hz
Reliability		AEC-Q200	
Packing Unit (1)		3000pcs./reel (Φ180)	

(1) Moisture prevention packing is unnecessary.
Moisture Sensitivity Level:Level1 (IPC/JEDEC J-STD-033)

Consult our sales representative for other specifications.

[mm]

Dimensions

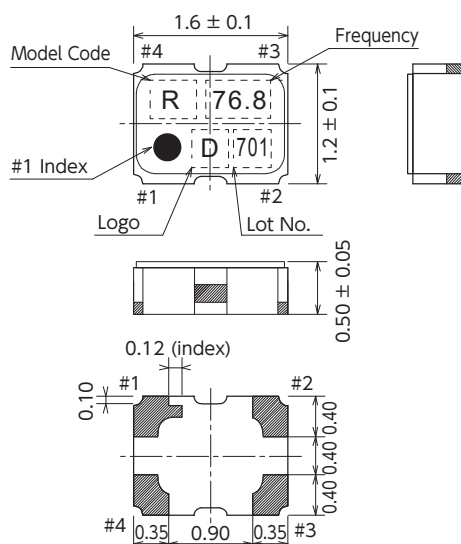

Recommended Land Pattern

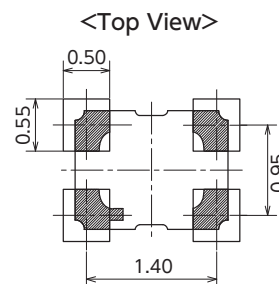

Pin Connections

Pin No.	Connection
#1	O.E. (Output Enable)
#2	GND
#3	Output
#4	Vcc

Output Enable
 H Oscillation
 L Stand by

High-precision SMD VC-TCXO/TCXO (For Automotive)

DSA1612SDN/DSA211SDN/DSA221SDN/DSA321SDN, DSB1612SDN/DSB211SDN/DSB221SDN/DSB321SDN

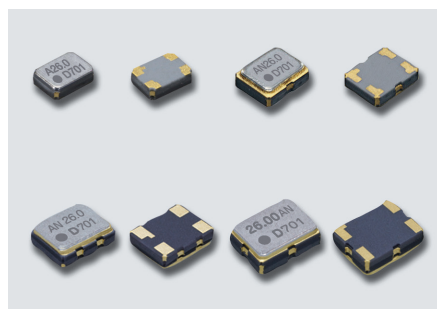

Actual size DSA1612SDN DSA211SDN
 DSA221SDN DSA321SDN

■ Features

- Low voltage operation
- Selectable between standard type and GPS/GNSS specialized type (DSB1612SDN)
- Clipped sine wave
- Low phase noise
- Single packaged structure
- AEC-Q200 Compliant (Option: Equivalent to AEC-Q100)

■ Applications

- Telematics, Satellite radio



[Type]

VC-TCXO	TCXO	Size
DSA1612SDN	DSB1612SDN	1612 size
DSA211SDN	DSB211SDN	2016 size
DSA221SDN	DSB221SDN	2520 size
DSA321SDN	DSB321SDN	3225 size

■ Standard Specification

Item \ Type	VC-TCXO				TCXO			
	DSA1612SDN	DSA211SDN	DSA221SDN	DSA321SDN	DSB1612SDN	DSB211SDN	DSB221SDN	DSB321SDN
Frequency Range	9.6 to 60MHz	9.6 to 52MHz	9.6 to 52MHz		9.6 to 60MHz	9.6 to 52MHz	9.6 to 52MHz	
Standard Frequency	19.2MHz/26MHz/38.4MHz/40MHz/52MHz				16.3676MHz/16.367667MHz/16.368MHz/16.369MHz/16.8MHz/26MHz/33.6MHz			
Supply Voltage Range	+1.68 to +3.5V							
Supply Voltage (Vcc)	+1.8V/+2.6V/+2.8V/+3.0V/+3.3V							
Current Consumption	+1.5mA max. (f≤26MHz)/+2.0mA max. (26MHz<f≤52MHz)/+2.5mA max. (f≤60MHz)							
Output Level	0.8Vp-p min. (f≤52MHz) (Clipped Sinewave/DC-coupled)							
Output Load	10kΩ//10pF							
Frequency Stability Tolerance	±1.5×10 ⁻⁶ max. (After 2 reflows)							
vs. Temperature	±1.0×10 ⁻⁶ , ±2.5×10 ⁻⁶ max./-40 to +85°C				±0.5×10 ⁻⁶ , ±2.5×10 ⁻⁶ max./-40 to +85°C			
vs. Supply Voltage	±0.2×10 ⁻⁶ max. (Vcc ±5%)							
vs. Load Variation	±0.2×10 ⁻⁶ max. (10kΩ//10pF±10%)							
vs. Aging	±1.0×10 ⁻⁶ max./year							
Frequency Control Control Sensitivity	±3.0×10 ⁻⁶ to ±5.0×10 ⁻⁶ /Vcont=+1.4V±1V @Vcc≥+2.6V				-			
	±3.0×10 ⁻⁶ to ±5.0×10 ⁻⁶ /Vcont=+0.9V±0.6V @Vcc=+1.8V				-			
Response Slope	Positive				-			
Start up Time	2.0ms max.							
Phase Noise	[f≤26MHz]		[26MHz<f≤40MHz]		[40MHz<f≤52MHz]			
Offset 100Hz	-115dBc/Hz		-110dBc/Hz		-105dBc/Hz			
Offset 1kHz	-130dBc/Hz		-130dBc/Hz		-125dBc/Hz			
Offset 10kHz	-150dBc/Hz		-150dBc/Hz		-145dBc/Hz			
Offset 100kHz	-155dBc/Hz		-155dBc/Hz		-150dBc/Hz			
Reliability	AEC-Q100/AEC-Q200							
Packing Unit (1)	DSA1612SDN/DSA211SDN/DSA221SDN, DSB1612SDN/DSB211SDN/DSB221SDN: 3000pcs./reel(φ180) DSA321SDN, DSB321SDN: 2000pcs./reel(φ180)							

(1) Moisture prevention packing is unnecessary.
 Moisture Sensitivity Level: LEVEL 1 (IPC/JEDEC J-STD-033)

Consult our sales representative for other specifications.

High-precision SMD VC-TCXO/TCXO (For Automotive)

For Automotive Applications

Dimensions

[mm]

■ DSA1612SDN/DSB1612SDN

Model Code
A: VC-TCXO (DSA1612SDN)
B: TCXO (DSB1612SDN)

Pin Connections	
Pin No.	Connection
#1	Vcont(VC-TCXO)/GND(TCXO)
#2	GND
#3	Output
#4	Vcc

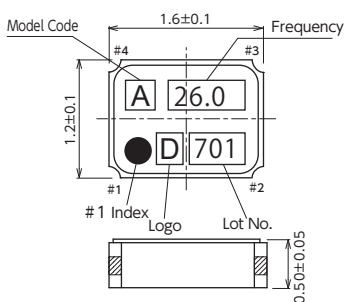

■ Recommended Land Pattern

<Top View>

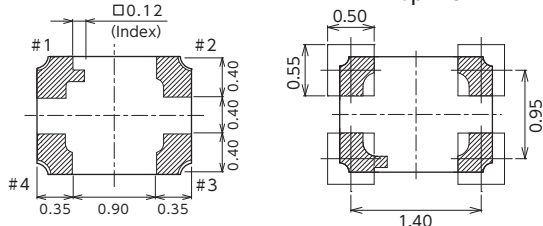

■ DSA211SDN/DSB211SDN

Model Code
AN: VC-TCXO (DSA211SDN)
BN: TCXO (DSB211SDN)

Pin Connections	
Pin No.	Connection
#1	Vcont(VC-TCXO)/GND(TCXO)
#2	GND
#3	Output
#4	Vcc

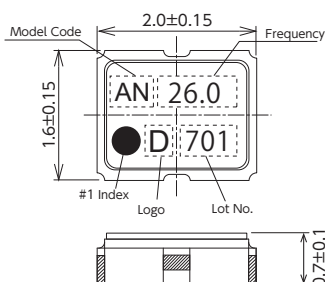

■ Recommended Land Pattern

<Top View>

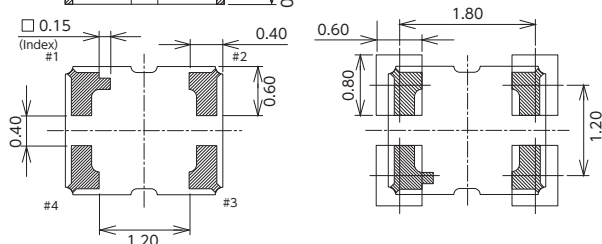

■ DSA221SDN/DSB221SDN

Model Code
AN: VC-TCXO (DSA221SDN)
BN: TCXO (DSB221SDN)

Pin Connections	
Pin No.	Connection
#1	Vcont(VC-TCXO)/GND(TCXO)
#2	GND
#3	Output
#4	Vcc

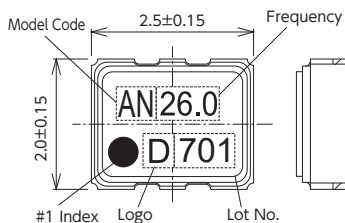

■ Recommended Land Pattern

<Top View>

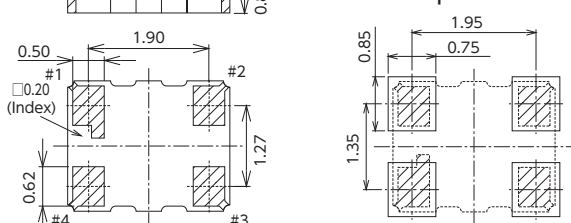

■ DSA321SDN/DSB321SDN

Model Code
AN: VC-TCXO (DSA321SDN)
BN: TCXO (DSB321SDN)

Pin Connections	
Pin No.	Connection
#1	Vcont(VC-TCXO)/GND(TCXO)
#2	GND
#3	Output
#4	Vcc

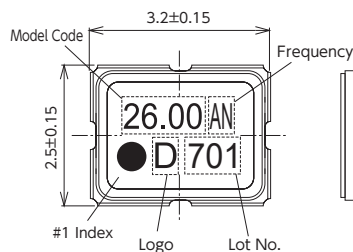

■ Recommended Land Pattern

<Top View>

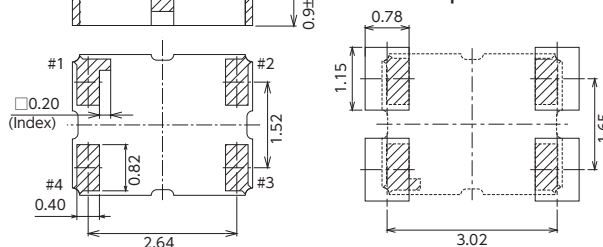

SMD TCXO (For Automotive)

DSB211SJA

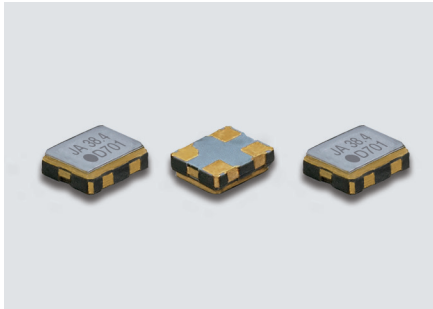

Actual size

Features

- Capable of operating over a wide temperature range, from -40 to $+105^{\circ}\text{C}$
- Supply voltage from $+1.7$ up to $+3.6\text{V}$
- CMOS Level Output
- Low phase noise
- Single package structure
- AEC-Q100/AEC-Q200 Compliant

Applications

- Automotive multimedia device, WiLAN and visual applications such as automotive camera



Standard Specification

Item	Type	DSB211SJA
Frequency Range		13 to 54MHz
Standard Frequency		19.2MHz/ 25MHz/ 26MHz/ 32MHz/ 38.4MHz/ 40MHz/ 48MHz/ 52MHz
Supply Voltage (Vcc)		+1.8V/ +2.5V/ +2.8V/ +3.3V
Current Consumption		5.0mA max. [No Load]
Stand-by Current (#1 pin "L" Level)		+10 μA max.
Frequency Stability Tolerance		$\pm 1.5 \times 10^{-6}$ max. (After 2 reflows)
vs. Temperature		$\pm 2.5 \times 10^{-6}$ max./ -40 to $+85^{\circ}\text{C}$ $\pm 5.0 \times 10^{-6}$ max./ -40 to $+105^{\circ}\text{C}$ $\pm 20 \times 10^{-6}$ max./ -40 to $+125^{\circ}\text{C}$ (Option)
vs. Aging		$\pm 1.0 \times 10^{-6}$ max./year
Symmetry		45 to 55% (50% Vcc Level)
0 Level Output Voltage		Vcc $\times 0.1\text{V}$ max.
1 Level Output Voltage		Vcc $\times 0.9\text{V}$ min.
Output Load		15pF
Rise and Fall Time		5ns max. (10% to 90% Vcc Level)
OE Pin 0 Level Input Voltage		Vcc $\times 0.2\text{V}$ max.
OE Pin 1 Level Input Voltage		Vcc $\times 0.8\text{V}$ min.
Start Up Time		3.0ms max.
Output Enable Time		3.0ms max.
Output Disable Time		150ns max.
Phase Noise		[$f \leq 26\text{MHz}$] Offset 1kHz -145dBc/Hz Offset 100kHz -158dBc/Hz
		[$26\text{MHz} < f \leq 52\text{MHz}$] -141dBc/Hz -157dBc/Hz
Reliability		AEC-Q100/AEC-Q200
Packing Unit (1)		3000pcs./reel ($\phi 180$)

(1) Moisture prevention packing is unnecessary.
Moisture Sensitivity Level: LEVEL 1 (IPC/JEDEC J-STD-033)

Consult our sales representative for other specifications.

[mm]

Dimensions

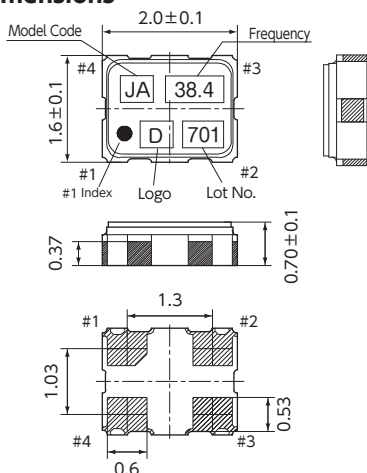

Pin Connections

Pin No.	Connection
#1	OE (Output Enable)
#2	GND
#3	Output
#4	Vcc

Function

#1 Input	#3 Output condition
H	Oscillation out
L	High Z

Recommended Land Pattern

<Top View>

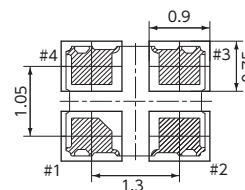

SMD TCXO (For Automotive)

DSK1612ATD

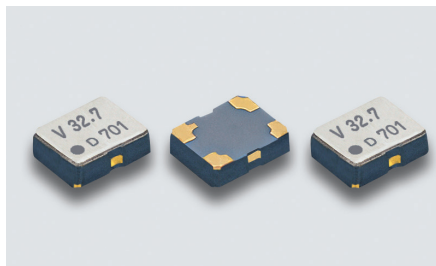

Actual size □

■ Features

- Digital temperature compensated type
- High precision: $\pm 5.0 \times 10^{-6}$ (-40 to +85°C)
- Low current consumption
- CMOS level output
- AEC-Q200 Compliant



■ Applications

- High precision clock source
- High precision clock source for RTC

■ Standard Specification

Item	Legend	Spec.				Condition
		min.	typ.	max.	Unit	
Output Frequency	f_0	-	32.768	-	kHz	
Supply Voltage Range	V _{CC}	+1.5	-	3.63	V	Temperature Compensated Operating
Frequency Tolerance	f_{tol}	-5.0	-	+5.0	$\times 10^{-6}$	V _{CC} =+1.8V or +3.3V, T _A =-40 to +85°C (Standard operating temperature range, Referenced to 32.768kHz)
Current Consumption	I _{CC1}	-	0.90	1.90	μA	V _{CC} =+1.8V, T _A =-40 to +85°C, at No Load (1)
		-	1.23	2.60		V _{CC} =+3.3V, T _A =-40 to +85°C, at No Load (1)
	I _{CC2}	-	1.26	2.43		V _{CC} =+1.8V, T _A =-40 to +85°C, at No Load Temperature Compensation Interval: 0.5s (standard specification) (2)
		-	1.59	3.12		V _{CC} =+3.3V, T _A =-40 to +85°C, at No Load Temperature Compensation Interval: 0.5s (standard specification) (2)
Symmetry	SYM	40	50	60	%	at 50% V _{CC}
0 Level Output Voltage	V _{OL}	-	-	V _{CC} ×0.1	V	
1 Level Output Voltage	V _{OH}	V _{CC} ×0.9	-	-	V	
Rise and Fall Time	t _r , t _f	-	-	40	ns	10 to 90% V _{CC} Level
Load Condition	L _{CMOS}	-	-	15	pF	
Start Up Time	T _{start}	-	-	0.5	s	
Reliability		AEC-Q200				
Packing Unit (3)		3000pcs./reel (φ180)				

- (1) I_{CC1} is the current value when the temperature compensation circuit is not operating. Consult our sales representative for other specifications.
 (2) I_{CC2} is the average current value when the temperature compensation circuit is operating and non-operating.
 (3) Moisture prevention packing is unnecessary. Moisture Sensitivity Level: Level1 (IPC/JEDEC J-STD-033)

[mm]

■ Dimensions

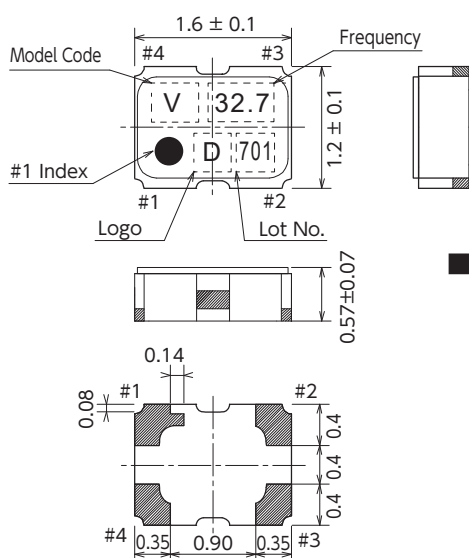

■ Recommended Land Pattern

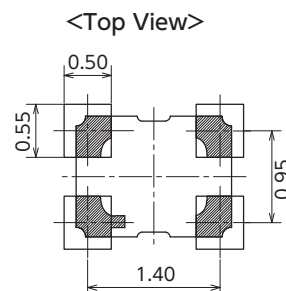

Pin No.	Connection
#1	GND
#2	Output
#3	V _{CC}
#4	GND

■ Current profile

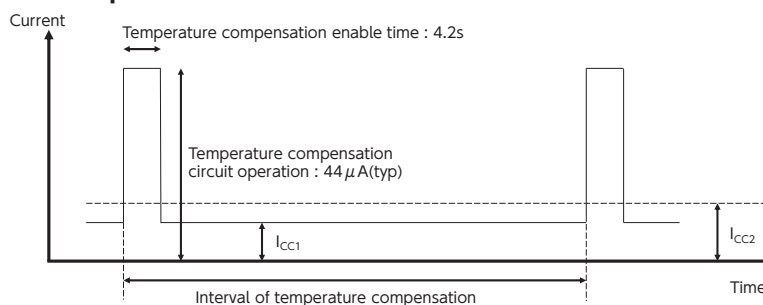

SMD TCXO (For Automotive)

DSK321STD

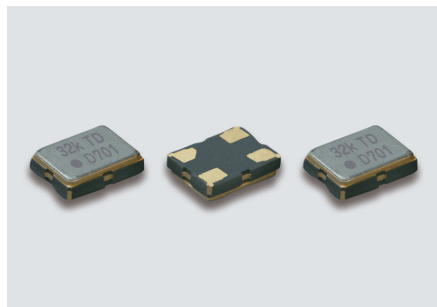

Actual size

Features

- Digital temperature compensated type
- High precision: $\pm 5.0 \times 10^{-6}$ (-40 to $+85^\circ\text{C}$)
- Low current consumption
- CMOS Level Output
- AEC-Q200 Compliant

Applications

- High precision clock source
- High precision clock source for RTC



Standard Specification

Item	Legend	Spec.				Condition
		min.	typ.	max.	Unit	
Output Frequency	f_0	—	32.768	—	kHz	
Supply Voltage Range	V_{CC}	+1.5	—	+3.63	V	(Temperature Compensated Operating)
Frequency Tolerance (Includes frequency tolerance at room temperature.)	f_{tol}	-5.0	—	+5.0	$\times 10^{-6}$	-40 to $+85^\circ\text{C}$
Current Consumption	I_{CC}	—	—	+3.5	μA	$V_{CC}=+1.8\text{V}$ or $+3.3\text{V}$, Temperature Compensation Interval:0.5s, No Load
		—	—	+3.2		
Symmetry	SYM	40	50	60	%	at 50% V_{CC}
0 Level Output Voltage	V_{OL}	—	—	$V_{CC} \times 0.1$	V	
1 Level Output Voltage	V_{OH}	$V_{CC} \times 0.9$	—	—		
Rise and Fall Time	t_r, t_f	—	—	50	ns	$V_{CC}=+1.5$ to $+3.63\text{V}$, 10 to 90% V_{CC} Level
Load Condition	L_{CMOS}	—	—	15	pF	
Start Up Time	T_{start}	—	—	1.0	s	
Reliability	AEC-Q200					
Packing Unit (1)	2000pcs./reel ($\phi 180$)					

(1) Moisture prevention packing is unnecessary.
Moisture Sensitivity Level:Level 1 (IPC/JEDEC J-STD-033)

Consult our sales representative for other specifications.

[mm]

Dimensions

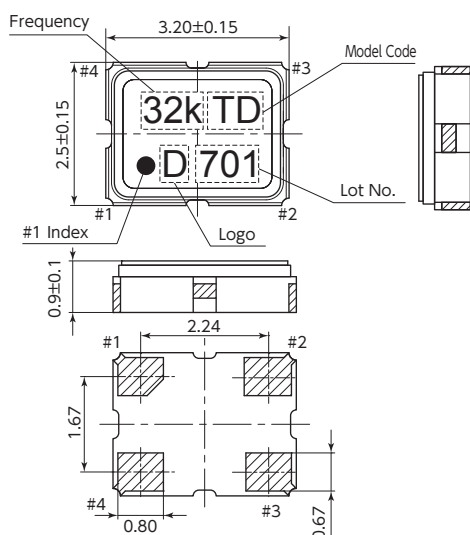

Recommended Land Pattern

<Top View>

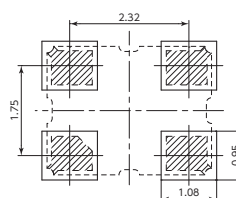

Pin No.	Connection
#1	V_{CC}
#2	GND
#3	Output
#4	V_{CC}

SMD Real Time Clock Module

DD3225TS

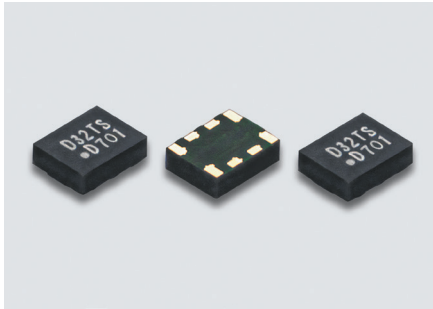

Actual size

Features

- Digital temperature compensated type
- High precision : $\pm 5.0 \times 10^{-6}$ (-40 to +85°C), $\pm 7.0 \times 10^{-6}$ (-40 to +105°C)
- Low current consumption
- Low voltage operation : +1.5 to +5.5V (Temperature Compensated Operating), +1.3 to +5.5V (Clock Timing Operating)
- I²C-BUS serial interface:400kHz fast-mode compatible
- Clock function:hour-minute-second, Calendar function with auto leap year adjustment:year-month-day-day of week
- Alarm interrupt function:day-day of week-hour-minute
- Fixed-cycle timer interrupt function:244μs to 255min
- Time update interrupt function:minute-second
- Clock output function:32.768kHz, 1024Hz, 32Hz, 1Hz
- Supply voltage detection function:
+1.5V temperature compensation operating voltage detection
+1.3V supply voltage under voltage detection
- CMOS Level Output
- AEC-Q100/AEC-Q200 compliant
- * "I²C-BUS" is a trademark of NXP semiconductors.



Applications

- High precision clock source
- Car navigation, Smart meter, Data logger

Standard Specification

Item	Legend	Spec.				Condition
		min.	typ.	max.	unit	
Output Frequency	f _o	-	32.768	-	kHz	
Supply Voltage Range	V _{cc}	+1.3	-	+5.5	V	(Clock Timing Operating)
	V _{tem}	+1.5	-	+5.5		(Temperature Compensated Operating)
	V _{int}	+1.5	-	+5.5		(Interface Operation) I ² C-BUS
Frequency Tolerance	f _{tol}	-5	-	+5	× 10 ⁻⁶	-40 to +85°C
		-7	-	+7		-40 to +105°C
Current Consumption	I _{cc1}	-	0.30	2.10	μA	V _{cc} = +3.0V
		-	0.42	2.90		V _{cc} = +5.0V
	I _{cc2}	-	0.90	2.80		V _{cc} = +3.0V
		-	1.30	4.00		V _{cc} = +5.0V
Load Condition	L _{CMOS}	-	-	15	pF	Temperature Compensation Interval:30s, SCL = SDA = INTN = V _{cc} ,OE = GND (Output Off)
Symmetry	SYM	40	-	60	%	50%V _{cc}
1 level Output Voltage	V _{OH}	0.8xV _{cc}	-	-	V	I _{OH} = -1mA
0 level Output Voltage	V _{OL}	-	-	0.2xV _{cc}	V	I _{OL} = 1mA
Rise / Fall Time	Tr/Tf	-	-	100	ns	20 to 80%V _{cc}
OE Pin 1 level Input Voltage	V _{IH}	0.8xV _{cc}	-	V _{cc}	V	
OE Pin 0 level Input Voltage	V _{IL}	0	-	0.2xV _{cc}	V	
Start Up Time	T _{start}	-	-	1	s	T _a = +25°C, V _{cc} = +1.3V
Reliability		AEC - Q100/AEC-Q200				
Packing Unit (1)		2000pcs./reel (φ 180)				

(1) Moisture prevention packing
Moisture sensitivity level : Level 2 (IPC/JEDEC J-STD-033)

Consult our sales representative for other specifications.

[mm]

Dimensions

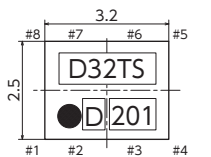

Function	
#1 Input	#5 Output Condition
H	Oscillation out
L	High Z

Marking	
(1) Type	D3225TS
(2) Logo	D
(3) Date code	Year(1 digit) + Week(2 digits) e.g.2022/1/1 → 201

Pin Function			
No.	Name	I/O	Description
#1	OE	I	Output control enable input (L:High impedance, H:Clock output)
#2	INTN	0	1Hz signal, alarm interrupt signal, fixed-cycle timer interrupt signal, and time update interrupt signal, Nch open-drain output.
#3	N.C.	-	Do not connect
#4	GND	-	Ground connection.
#5	Output	0	Clock output connection.
#6	SCL	I	I ² C-BUS serial interface clock input connection.
#7	SDA	I/O	I ² C-BUS serial interface data input/output connection.
#8	V _{cc}	-	Supply Voltage

Recommended Land Pattern

<Top View>

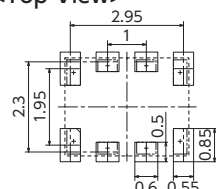
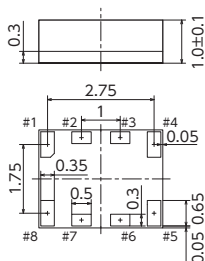

Quartz Devices

Monolithic crystal filters

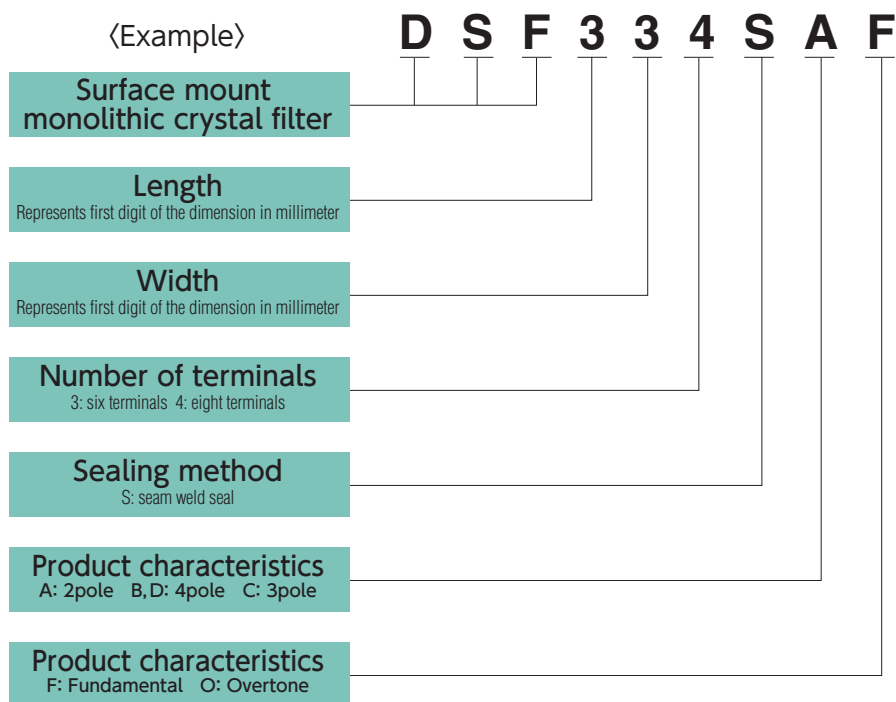
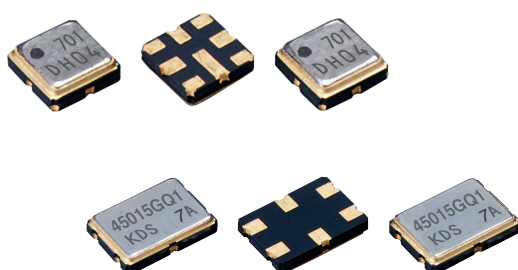

Monolithic Crystal Filters

Description

A monolithic crystal filter is a device that has a frequency screening function. From a wide frequency range, it passes a specific frequency and attenuates unnecessary ones. It plays the role of extracting desired frequency in radio communication equipment.

With the high Q factor of the crystal, these filters feature low loss, steep attenuation characteristics and high stability, as well as good temperature drifting characteristics.

Terminology

①	Nominal Frequency f_0 (MHz)	Nominal value of center frequency.
②	Pass Bandwidth $P \pm$ (kHz), A_1 (dB)	Frequency interval at which relative attenuation is guaranteed to be equal to or less than a given value, A_1 .
③	Stop Bandwidth $S \pm$ (kHz), A_2 (dB)	Frequency interval at which relative attenuation is guaranteed to be equal to or more than a given value, A_2 .
④	Ripple R (dB)	The maximum difference between the minimum attenuation and the minimum loss within the pass band.
⑤	Insertion Loss L (dB)	Difference in attenuation when filter is inserted and not inserted. Can be either of the following. Minimum loss: Minimum value of insertion loss. Insertion loss at f_0 : Insertion loss at nominal frequency.
⑥	Guaranteed Attenuation A_3 (dB)	Relative attenuation guaranteed in a specific range within the stop band.
⑦	Spurious A_4 (dB)	Relative attenuation produced as a result of spurious frequencies in a specific range within the stop band.
⑧	Tolerance in Group Delay Time Δt (μs)	Difference between the maximum value and minimum value of the group delay time within the pass band.
Terminating Impedance $R_t // C_t$ ($\Omega // pF$)		Signal-source impedance or loading impedance as viewed from the filter side. Expressed as resistance and parallel capacitance including floating capacitance.
Coupling Capacitance C_c (pF)		Capacitance of the connection between elements for 4pole filter.
Operating Temperature Range		Temperature range over which the monolithic crystal filter can be operated within allowable deviation range.

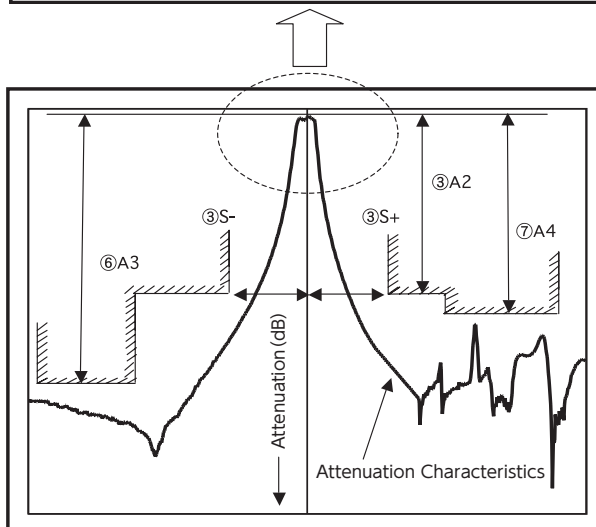
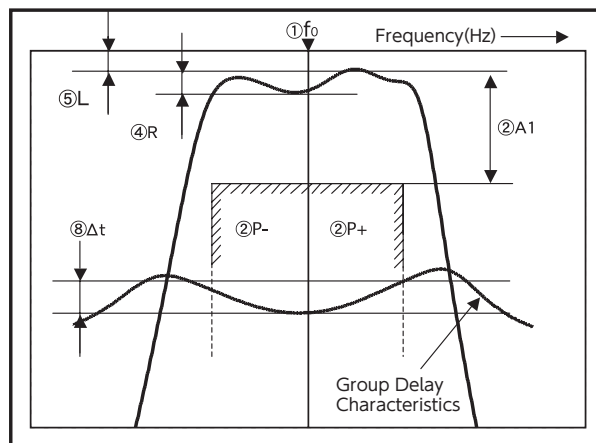

Pole VS Shape factor

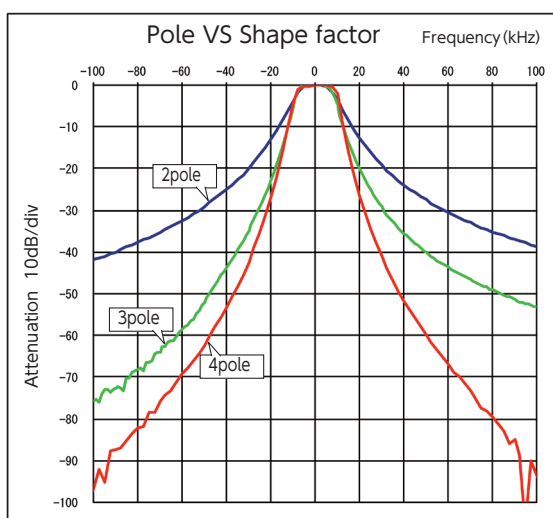

SMD Monolithic Crystal Filters

DSF334S 2POLE/DSF334S 3POLE/DSF444S 2POLE/DSF444S 3POLE

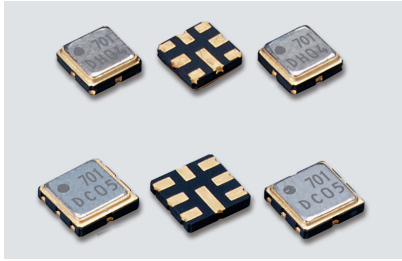

Actual size DSF334S DSF444S

■ Features

- DSF334S 2POLE, 3POLE: 3030 size, 0.9mm height, miniature SMD crystal filter and lightweight(0.03g)
- DSF444S 2POLE, 3POLE: 3838 size, 0.9mm height, miniature SMD crystal filter and lightweight(0.05g)
- Excellent shock and vibration resistance.
- Low spurious

■ Applications

- Radio communications



■ Standard Specification

Type	DSF334SAF	DSF334SAF	DSF334SCF	DSF444SAF	DSF444SCF
Model	D50003AM	D50015AM	DA6115FM	D50003AL	D73313FL
Pole	2	2	3	2	3
Overtone Order	Fundamental	Fundamental	Fundamental	Fundamental	Fundamental
Nominal Frequency	50.000 MHz	50.000 MHz	161.950 MHz	50.000 MHz	73.350 MHz
Pass Bandwidth	±1.5kHz min./3dB	±7.5kHz min./3dB	±7.5kHz min./3dB	±1.75kHz min./3dB	±6.5kHz min./3dB
Stop Bandwidth	±18kHz max./15dB	±25kHz max./13dB	±20dB min./50kHz	±16kHz max./15dB	±20kHz max./18dB
Ripple	1dB max.	1dB max.	1dB max.	1dB max.	1dB max.
Insertion Loss	40dB max.	3.5dB max.	5dB max.	4dB max.	3.5dB max.
Guaranteed Attenuation	60dB min.	60dB min.	70dB min.	50dB min.	70dB min.
Terminating Impedance	400Ω//9pF	750Ω//3pF	120Ω// -0.8pF	380Ω//9.0pF	380Ω// -1pF
Operating Temperature Range	-20 to +70°C				
Packing Unit (1)	2000pcs./reel(φ180)			1000pcs./reel(φ180)	

1) Moisture prevention packing is unnecessary.
Moisture Sensitivity Level: LEVEL 1 (IPC/JEDEC J-STD-03)

Consult our sales representative for other specifications.

■ DSF334S [mm]

■ Dimensions

Pin No.	Connection
#1	Input
#2	GND.
#3	GND.
#4	GND.
#5	Output
#6	GND.
#7	GND.
#8	GND.

■ Recommended Land Pattern (Top View)

■ Measurement Circuit

■ DSF444S [mm]

■ Dimensions

Pin No.	Connection
#1	Input
#2	GND.
#3	GND.
#4	GND.
#5	Output
#6	GND.
#7	GND.
#8	GND.

■ Recommended Land Pattern (Top View)

■ Measurement Circuit

SMD Monolithic Crystal Filters

DSF633S 2POLE/DSF633S 4POLE

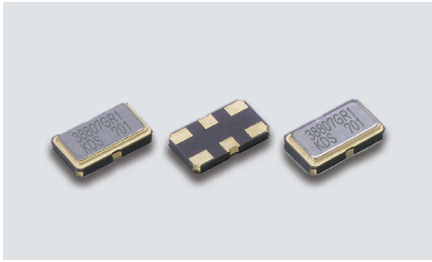

Actual size

■ Features

- 6035 size, lightweight (0.072g) and miniature SMD crystal filter. Just 1.1mm height.
- 4 pole function in a single package.
- Excellent guaranteed attenuation.
- Excellent shock and vibration resistance.

■ Applications

- Radio communications



■ Standard Specification

Type	DSF633SDF				
Model	D38807GR	D49903GR	D58010GR	D73312GR	DA3050GR
Pole	4	4	4	4	4
Overtone Order	Fundamental	Fundamental	Fundamental	Fundamental	Fundamental
Nominal Frequency	38.850 MHz	49.950 MHz	58.050 MHz	73.350MHz	130.000MHz
Pass Bandwidth	±3.75kHz min./3dB	±1.75kHz min./3dB	±5.0kHz min./3dB	±6.0kHz min./3dB	±25.0kHz min./3dB
Stop Bandwidth	±15.0kHz min./35dB	±6.25kHz max./20dB	±12.5kHz max./25dB	±25kHz max./40dB	±100kHz max./35dB
Ripple	1dB max.	1dB max.	1dB max.	1dB max.	1dB max.
Insertion Loss	6dB max.	6dB max.	5dB max.	5dB max.	5dB max.
Guaranteed Attenuation	76dB min.	76dB min.	80dB min.	80dB min.	70dB min.
Terminating Impedance	710Ω//4pF Cc=12.5pF	150Ω//11pF Cc=33pF	450Ω//4.5pF Cc=9.5pF	380Ω//5pF Cc=11pF	560Ω//0.2pF Cc=3.5pF
Operating Temperature Range	-20 to +70°C				
Packing Unit (1)	1000pcs./reel(φ180)				

(1) Moisture prevention packing is unnecessary.
Moisture Sensitivity Level: LEVEL 1 (IPC/JEDEC J-STD-033)

Consult our sales representative for other specifications.

■ DSF633SA

[mm]

■ Dimensions

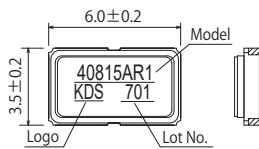

Pin No.	Connection
#1	INPUT
#2	GND.
#3	GND.
#4	OUTPUT
#5	GND.
#6	GND.

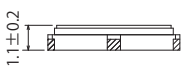

■ Recommended Land Pattern <Top View>

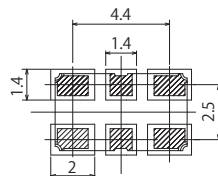
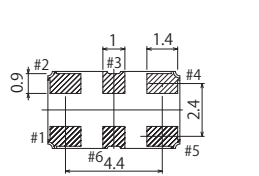

■ Measurement Circuit

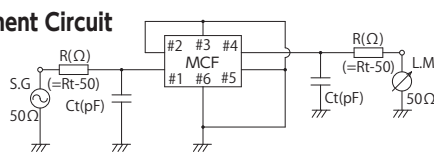

■ DSF633SD

[mm]

■ Dimensions

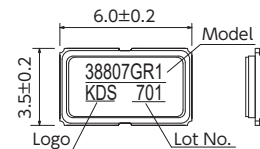

Pin No.	Connection
#1	INPUT
#2	GND.
#3	Connect with #6
#4	OUTPUT
#5	GND.
#6	Connect with #3

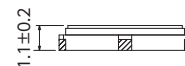

■ Recommended Land Pattern <Top View>

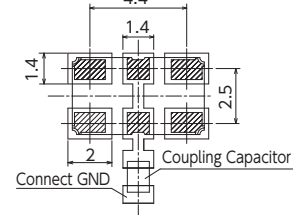
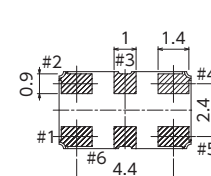

■ Measurement Circuit

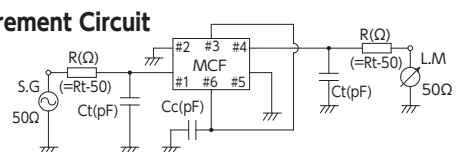

■ Characteristics Chart (fo=49.95MHz, P=±1.75kHz)

■ Characteristics Chart (fo=73.350MHz, P=±6.0kHz)

■ Characteristics Chart (fo=130.000MHz, P=±25.0kHz)

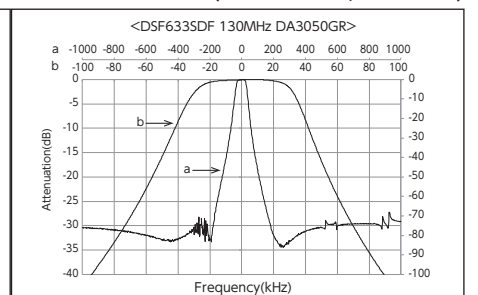
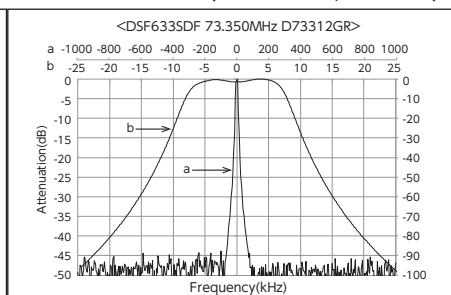
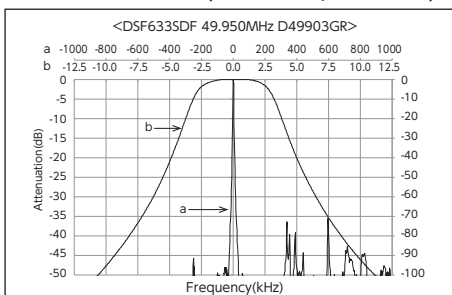

SMD Monolithic Crystal Filters

DSF753S 2POLE/DSF753S 3POLE/DSF753S 4POLE

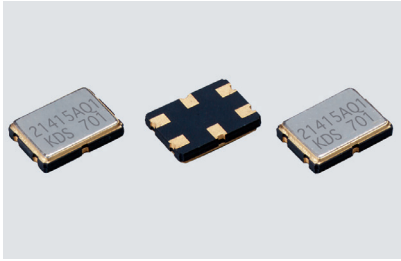

Actual size

■ Features

- 7050 size, lightweight (0.15g) and miniature SMD crystal filter. Just 1.3mm height.
- Excellent shock and vibration resistance

■ Applications

- Radio communications



■ Standard Specification

Type	DSF753SAF	DSF753SCF	DSF753SBF/DSF753SDF		DSF753SDO	
Model	D21415AQ	D45015FQ	D46307GQ	D50810GQ	D73312GQ	DA4917GQ
Pole	2	3	4	4	4	4
Overtone Order	Fundamental	Fundamental	Fundamental	Fundamental	Fundamental	3rd overtone
Nominal Frequency	21.400 MHz	45.000 MHz	46.350MHz	50.850MHz	73.350MHz	149.9725 MHz
Pass Bandwidth	±7.5kHz min./3dB	±7.5kHz min./3dB	±3.5kHz min./3dB	±5.0kHz min./3dB	±6.0kHz min./3dB	±8.68kHz min./3dB
Stop Bandwidth	±25kHz max./18dB	±50kHz max./30dB	±18kHz max./40dB	±20kHz max./40dB	±25kHz max./40dB	±15dB min./30kHz
Ripple	1dB max.	1dB max.	1dB max.	1dB max.	1dB max.	1dB max.
Insertion Loss	2dB max.	3dB max.	5dB max.	5dB max.	5dB max.	6dB max.
Guaranteed Attenuation	70dB min.	70dB min.	80dB min.	80dB min.	80dB min.	60dB min.
Terminating Impedance	1500Ω//2.5pF	700Ω//−1pF	400Ω//4pF Cc=17.5pF	560Ω//4pF Cc=9.7pF	450Ω//4pF Cc=9.2pF	800Ω//−0.2pF Cc=0.6pF
Operating Temperature Range	−20 to +70°C					
Packing Unit (1)	1000pcs./reel(φ 180)					

(1) Moisture prevention packing is unnecessary.
Moisture Sensitivity Level: LEVEL 1 (IPC/JEDEC J-STD-033)

Consult our sales representative for other specifications.

■ DSF753SA/DSF753SC [mm]

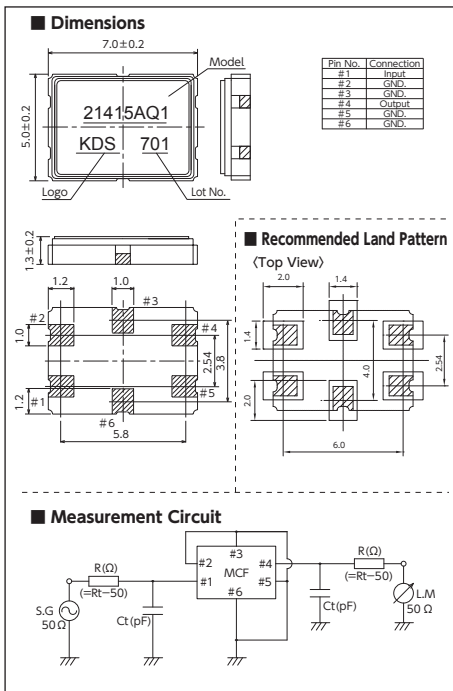

■ DSF753SB/DSF753SD [mm]

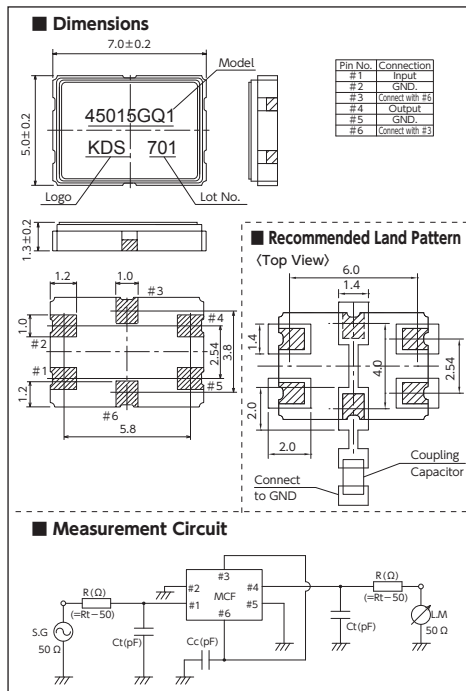

■ Characteristics Chart (fo=45MHz, P=±7.5kHz 2POLE)

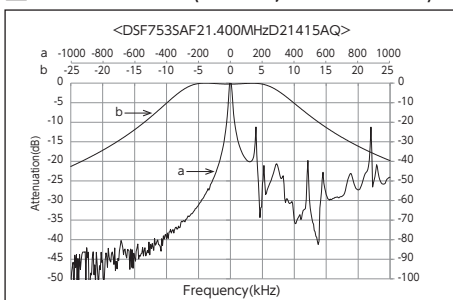

■ Characteristics Chart (fo=45MHz, P=±7.5kHz 4POLE)

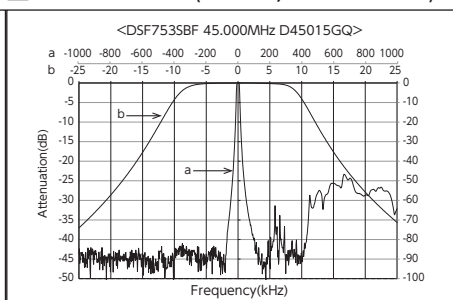

■ Characteristics Chart (fo=73.350MHz, P=±6.0kHz 4POLE)

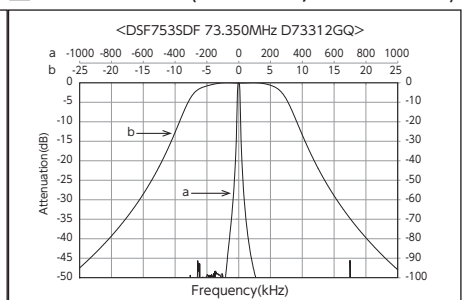

Silicon Timing Devices

MEMS oscillators

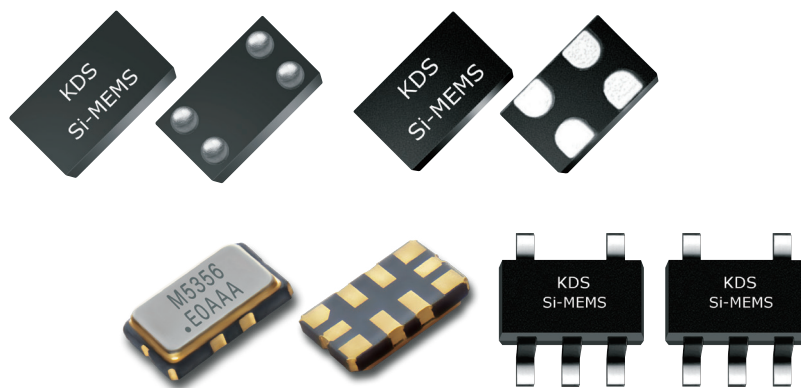

32 kHz MEMS Oscillators / 32 kHz TC-MO - μ Power

MO1532/MO1552/MO1630/MO1566/MO1568

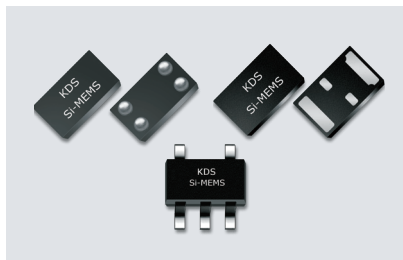

■ Features

- Fixed 32.768 kHz
- Ultra-low power
- Internal filtering eliminates external Vdd bypass cap

■ Applications

- Mobile Phones, Tablets
- Health and wellness monitors, Fitness Watches
- Pulse-per-second timekeeping, RTC reference clock
- Battery Management Timekeeping



Model	Output Frequency (kHz)	Frequency Tolerance ($\times 10^{-6}$)	Supply Voltage (V)	Current Consumption (μ A Typ.)	Size (mm)	Output
MO1532	32.768	± 10 room; 75, 100 over temp.	+1.2 to +3.63	+0.90	1.5 \times 0.8 \times 0.6 (CSP)	NanoDrive™ LVCMOS
MO1552 TC-MO		± 5 , ± 10 , ± 20 over temp.	+1.5 to +3.63	+0.99		
MO1566 Super TC-MO		± 3 , 5 all inclusive	+1.8	+4.5	1.5 \times 0.8 \times 0.6 (CSP)	LVCMOS
MO1568 Super TC-MO		± 5 all inclusive After Overmold/Underfill				
MO1630 -40 to +105°C	16.384, 32.768	± 20 room; $\pm 75, 100, 150$ over temp.	+1.5 to +3.63	+1.00	2.0 \times 1.2 \times 0.6 (QFN) 2.9 \times 2.8 \times 1.3 (SOT23-5)	LVCMOS

■ Standard Specification (MO1532)

Item	Legend	Min.	Typ.	Max.	Unit	Condition
Output Frequency Range	F _{out}	32.768			kHz	
Supply Voltage	V _{dd}	+1.2	-	+3.63	V	T _A = -10°C to +70°C
		+1.5	-	+3.63		T _A = -40°C to +85°C
Operating Temperature Range	T _{use}	-10 to +70 / -40 to +85			°C	
Frequency Stability [1]	F _{stab}	-	-	+75	$\times 10^{-6}$	T _A = -10°C to +70°C, V _{dd} : +1.5V to +3.63V
		-	-	+100		T _A = -40°C to +85°C, V _{dd} : +1.5V to +3.63V
		-	-	+250		T _A = -10°C to +70°C, V _{dd} : +1.2V to +1.5V
Frequency Tolerance [2]	F _{tol}	-	-	+10	$\times 10^{-6}$	T _A = +25° C, post reflow, V _{dd} : +1.5V to +3.63V
		-	-	+20		T _A = +25° C, post reflow with board-level underfill, V _{dd} : +1.5V to +3.63V
First Year Aging	F _{aging1}	-1.0	-	+1.0	$\times 10^{-6}$	T _A = +25°C
Core Operating Current [3]	I _{dd}	-	+0.9	-	μ A	T _A = +25°C, V _{dd} : +1.8V. No load
		-	-	+1.3		T _A = -10°C to +70°C, V _{dd} max: +3.63V. No load
		-	-	+1.4		T _A = -40°C to +85°C, V _{dd} max: +3.63V. No load
Start-up Time [4]	T _{start}	-	180	300	ms	T _A = -40°C \leq T _A \leq +50°C, valid output
		-	-	450		T _A = +50°C < T _A \leq +85°C, valid output
LVCMOS Output Option, T _A = -40°C to +85°C, typical values are at T _A = +25°C						
Duty Cycle	DC	48	-	52	%	
Output Low Voltage	V _{OL}	-	-	V _{dd} \times 0.1	V	V _{dd} : +1.5V to +3.63V, I _{OL} = +10 μ A, 15 pF
Output High Voltage	V _{OH}	V _{dd} \times 0.9	-	-	V	V _{dd} : +1.5V to +3.63V, I _{OH} = -10 μ A, 15 pF
Rise and Fall Time	Tr, Tf	-	100	200	ns	10 to 90% (V _{dd}), 15 pF load, V _{dd} = +1.5V to +3.63V
		-	-	50		10 to 90% (V _{dd}), 5 pF load, V _{dd} \geq +1.62V
Packing Unit	1000pcs./reel (ϕ 180) or 3000pcs./reel (ϕ 180)					

[1]. Measured peak-to-peak. Inclusive of Initial Tolerance at +25° C, and variations over operating temperature, rated power supply voltage and load. Stability is specified for two operating voltage ranges. Stability progressively degrades with supply voltage below +1.5V.

[2]. Measured peak-to-peak. Tested with Keysight 53132A frequency counter. Due to the low operating frequency, the gate time must be ≥ 100 ms to ensure an accurate frequency measurement.

[3]. Core operating current does not include output driver operating current or load current. To derive total operating current (no load), add core operating current + (+0.065 μ A/V) \times (output voltage swing).

[4]. Measured from the time V_{dd} reaches +1.5V.

MEMS Oscillators / TC-MO - μ Power

MO1534/MO1569/MO1576/MO8021

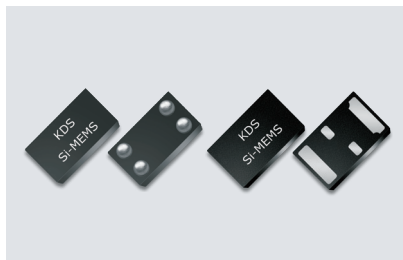

■ Features

- Ultra-low power
- Internal filtering eliminates external Vdd bypass cap

■ Applications

- Tablets, Wearable, Portable audio
- Health and wellness monitors, Fitness bands
- IoT devices
- Input devices



Model	Output Frequency (kHz)	Frequency Tolerance ($\times 10^{-6}$)	Supply Voltage (V)	Current Consumption (μ A Typ.)	Size (mm)	Output
MO1534	1 Hz to 32.768 kHz	± 20 room; $\pm 75, 100, 150$ over temp	+1.2 to +3.63	+0.90	1.5 \times 0.8 \times 0.6 (CSP) 2.0 \times 1.2 \times 0.6 (QFN)	NanoDrive™ LVCMOS
MO1569	1 Hz to 462kHz	± 50	+1.62 to +3.63	+2.0 (100 kHz)	1.5 \times 0.8 \times 0.6 (CSP)	LVCMOS
MO1576 Super TC-MO	1 Hz to 2.5 MHz	± 5 all inclusive		+8.0 (100 kHz)		
MO8021	1 Hz to 26 MHz	± 100	+1.62 to +1.98, +2.25 to +3.63	+6 to +340 (0.9 μ A stby)		

■ Standard Specification (MO8021)

Item	Legend	Min.	Typ.	Max.	Unit	Condition
Output Frequency Range	f	1	-	26	MHz	
Operating Supply Voltage	Vdd	+1.62	+1.8	+1.98	V	Any voltage from +2.25 to +3.63V
		+2.25	-	+3.63		
Operating Temperature Range	T _{use}	-20	-	+70	°C	Extended Commercial Industrial
		-40	-	+85		
Frequency Stability	F _{tol}	-15	-	+15	$\times 10^{-6}$	Frequency offset at +25°C post reflow
Frequency Tolerance	F _{stab}	-100	-	+100	$\times 10^{-6}$	Inclusive of initial tolerance, and variations over operating temperature, rated power supply voltage and output load.
First Year Aging	F _{aging1}	-3.0	-	+3.0	$\times 10^{-6}$	T _A = +25°C
Current Consumption [1]	I _{dd}	-	+60	-	μ A	f = 3.072 MHz, Vdd = +1.8V, no load
		-	+110	+130		f = 6.144 MHz, Vdd = +1.8V, no load
		-	+230	+270		f = 6.144 MHz, Vdd = +1.8V, 10 pF load
		-	+160	-		f = 12 MHz, Vdd = +1.8V, no load
		-	-	+160		f = 6.144 MHz, Vdd = +2.25V to +3.63V, no load
Standby Current	I _{std}	-	+0.7	+1.3	μ A	Vdd = +1.8V, ST pin = HIGH, output is weakly pulled down
		-	-	+1.5		Vdd = +2.25V to +3.63V, ST pin = HIGH, output is weakly pulled down
Duty Cycle	DC	45	-	55	%	
Output Low Voltage	V _{OL}	-	-	Vdd \times 0.1	V	I _{OL} = +0.5 mA
Output High Voltage	V _{OH}	Vdd \times 0.9	-	-	V	I _{OH} = -0.5 mA
Rise and Fall Time	Tr, Tf	-	+4.0	+8.0	ns	20% to 80%
Input Low Voltage	V _{IL}	-	-	Vdd \times 0.2	V	
Input High Voltage	V _{IH}	Vdd \times 0.8	-	-	V	
Start-up Time	T _{start}	-	75	150	ms	Measured from the time Vdd reaches 90% of its final value
Standby Time	T _{stdby}	-	-	20	μ s	Measured from the time ST pin crosses 50% threshold
Resume Time	T _{resume}	-	2.0	3.0	ms	Measured from the time ST pin crosses 50% threshold
RMS Period Jitter	T _{jitt}	-	75	110	ps	f = 6.144 MHz, Vdd = +1.8V
		-	-	110		f = 6.144 MHz, Vdd = +2.25V to +3.63V
RMS Phase Jitter (random)	T _{phj}	-	0.8	2.5	ns	f = 6.144 MHz, Integration bandwidth = 100 Hz to 40 kHz Vdd = +1.8V, Note [2]
		-	-	2.5		f = 6.144 MHz, Integration bandwidth = 100 Hz ~ 40 kHz Vdd = +2.25V to +3.63V, Note [2]
Packing Unit		1000pcs./reel (ϕ 180) or 3000pcs./reel (ϕ 180)				

[1]. Supply current with load is a function of the output frequency and output load.

For any given output frequency, the capacitive loading will increase supply current equal to C_{load} \times Vdd \times f(MHz).

[2]. Max spec inclusive of +25 mV peak-to-peak sinusoidal noise on Vdd. Noise frequency 100 Hz to 20 MHz.

MEMS Oscillators - Super Low Jitter

MO9365/MO9366/MO9367

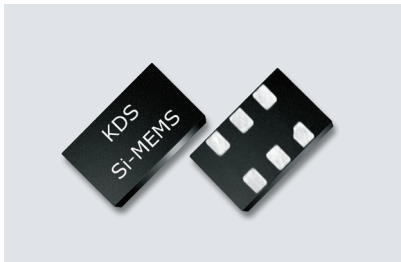

■ Features

- Industry-Standard packages: 3.2×2.5 mm, 5.0×3.2 mm, 7.0×5.0 mm
- Output signaling types: LVPECL, LVDS, HCSL
- Frequency tolerance as low as $\pm 10 \times 10^{-6}$
- 0.1 ps RMS phase jitter (random) for Ethernet applications

■ Applications

- 10/40GB Ethernet, SONET, SATA, SAS, Fibre Channel
- Telecom, networking, instrumentation, storage, servers



Model	Output Frequency (MHz)	Frequency Tolerance ($\times 10^{-6}$)	Supply Voltage (V)	Current Consumption (mA Typ.)	Size (mm)	Output
MO9365	32 Standard Frequencies	$\pm 10, \pm 20, \pm 25, \pm 50$	+2.25 to +3.63	+76 to +84	3.2×2.5×0.8, 5.0×3.2×0.8, 7.0×5.0×1.0 (QFN)	LVPECL LVDS HCSL
MO9366	1 to 220					
MO9367	220 to 725					

■ Standard Specification (MO9366)

Item	Legend	Min.	Typ.	Max.	Unit	Condition
Output Frequency Range	f	1	-	220	MHz	Accurate to 6 decimal places
Supply Voltage	V _{dd}	+2.25	+2.50	+2.75	V	
		+2.52	+2.80	+3.08		
		+2.70	+3.00	+3.30		
		+2.97	+3.30	+3.63		
Operating Temperature Range	T _{use}	-20	-	+70	°C	Extended Commercial
		-40	-	+85		Industrial
		-40	-	+95		Extended Industrial
		-40	-	+105		
Frequency Tolerance	F _{stab}	-10	-	+10	$\times 10^{-6}$	Inclusive of initial tolerance, and variations over operating temperature, rated power supply voltage and output load.
		-20	-	+20		
		-25	-	+25		
		-50	-	+50		
First Year Aging	F _{aging1}	-	± 1	-	$\times 10^{-6}$	T _A = +25°C
Duty Cycle	DC	45	-	55	%	
OE Disable Supply Current	I _{oe}	-	-	+58	mA	OE = Low
Input Low Voltage	V _{IL}	-	-	V _{dd} ×0.3	V	Pin 1, OE
Input High Voltage	V _{IH}	V _{dd} ×0.7	-	-	V	Pin 1, OE
Start-up Time	T _{start}	-	-	3.0	ms	Measured from the time V _{dd} reaches its rated minimum value
Enable and Disable Time	T _{oe}	-	-	3.8	μs	f = 156.25 MHz
RMS Phase Jitter [1]	T _{jitt}	-	1	1.6	ps	f = 100, 156.25 or 212.5 MHz, V _{dd} = 3.3 or 2.5 V
LVPECL output						
Current Consumption	I _{dd}	-	-	+89	mA	Excluding Load Termination Current, V _{dd} = +3.3V or +2.5V
Output Low Voltage	V _{OL}	V _{dd} - 1.9	-	V _{dd} - 1.5	V	
Output High Voltage	V _{OH}	V _{dd} - 1.1	-	V _{dd} - 0.7	V	
Differential Output Voltage	V _{Swing}	1.2	1.6	2.0	V	
Rise and Fall Time	T _r , T _f	-	225	290	ps	20% to 80%
RMS Phase Jitter [random]	T _{phj}	-	0.225	0.275	ps	Note [2]
LVDS output						
Current Consumption	I _{dd}	-	-	+79	mA	Excluding Load Termination Current, V _{dd} = +3.3V or +2.5V
Differential Output Voltage	V _{OD}	+250	-	+450	mV	
V _{OD} Magnitude Change	ΔV _{OD}	-	-	+50	mV	
Offset Voltage	V _{OS}	+1.125	-	+1.375	V	
V _{OS} Magnitude Change	ΔV _{OS}	-	-	+50	mV	
Rise and Fall Time	T _r , T _f	-	400	470	ps	Measured with 2 pF capacitive loading to GND, 20% to 80%
RMS Phase Jitter [random]	T _{phj}	-	0.235	0.275	ps	Note [2]
HCSL output						
Current Consumption	I _{dd}	-	-	+89	mA	Excluding Load Termination Current, V _{dd} = +3.3V or +2.5V
Output Voltage Low	V _{OL}	-0.05	-	+0.08	V	
Output Voltage High	V _{OH}	0.6	-	+0.9	V	
Differential Output Voltage	V _{Swing}	1.0	1.4	1.8	V	
Rise and Fall Time	T _r , T _f	-	360	465	ps	Measured with 2 pF capacitive loading to GND, 20% to 80%
RMS Phase Jitter [random]	T _{phj}	-	0.225	0.275	ps	Note [2]
Packing Unit		1000pcs./reel (φ 180) or 3000pcs./reel (φ 180: 3225 package)				

[1]. Measured according to JESD65B

[2]. 5.0×3.2 and 3.2×2.5 mm package, f = 156.25 MHz, Integration bandwidth = 12 kHz to 20 MHz, all V_{dd} levels, includes spurs. Temperature ranges -20 to +70°C and -40 to +85°C

MEMS Oscillators - Low Jitter

MO9120/MO9121/MO9122/MO8208/MO8209

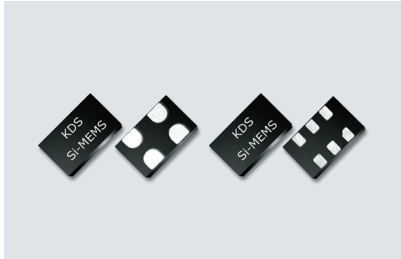

■ Features

- Frequency tolerance as low as $\pm 10 \times 10^{-6}$
- Ultra-Low phase Jitter

■ Applications

- Computing, storage, networking
- Telecom, industrial control
- SATA, SAS, Ethernet, PCI Express, video, WiFi



Model	Output Frequency (MHz)	Frequency Tolerance ($\times 10^{-6}$)	Supply Voltage (V)	Current Consumption (mA Typ.)	Size (mm)	Output
MO9120	25 to 212.5	$\pm 10, \pm 20, \pm 25, \pm 50$	+2.25 to +3.63	+54 to +69	3.2×2.5×0.8, 5.0×3.2×0.8, 7.0×5.0×1.0 (QFN)	LVPECL LVDS
MO9121	1 to 220					
MO9122	220 to 625					
MO8208	1 to 80			+29 to +36 (+10 μ A stby)	2.7×2.4×0.8, 3.2×2.5×0.8, 5.0×3.2×0.8, 7.0×5.0×1.0 (QFN)	LVCMOS
MO8209	80 to 220					

■ Standard Specification (MO9121)

Item	Legend	Min.	Typ.	Max.	Unit	Condition
Output Frequency Range	f	1	-	220	MHz	Refer to datasheet for exact list of supported frequencies
Supply Voltage	Vdd	+2.97	+3.3	+3.63	V	
		+2.25	+2.5	+2.75		
		+2.25	-	+3.63		
Operating Temperature Range	T _{use}	-20	-	+70	°C	Extended Commercial
		-40	-	+85		Industrial
Frequency Tolerance	F _{stab}	-10	-	+10	$\times 10^{-6}$	Inclusive of initial tolerance, and variations over operating temperature, rated power supply voltage and output load.
		-20	-	+20		
		-25	-	+25		
		-50	-	+50		
First Year Aging	F _{aging1}	-2.0	-	+2.0	$\times 10^{-6}$	T _A = +25°C
10-year Aging	F _{aging10}	-5.0	-	+5.0	$\times 10^{-6}$	T _A = +25°C
Duty Cycle	DC	45	-	55	%	
Input Low Voltage	V _{IL}	-	-	Vdd×0.3	V	Pin 1, OE or \overline{ST}
Input High Voltage	V _{IH}	Vdd×0.7	-	-	V	Pin 1, OE or \overline{ST}
Start-up Time	T _{start}	-	6.0	10	ms	Measured from the time Vdd reaches its rated minimum value.
Resume Time	T _{resume}	-	6.0	10	ms	In Standby mode, measured from the time ST pin crosses 50% threshold.
LVPECL, DC and AC Characteristics						
Current Consumption	I _{dd}	-	+61	+69	mA	Excluding Load Termination Current, Vdd = +3.3V or +2.5V
OE Disable Supply Current	I _{oe}	-	-	+35	mA	OE = Low
Standby Current	I _{std}	-	-	+100	μ A	\overline{ST} = Low, for all Vdds
Output Low Voltage	V _{OL}	Vdd - 1.9	-	Vdd - 1.5	V	
Output High Voltage	V _{OH}	Vdd - 1.1	-	Vdd - 0.7	V	
Rise and Fall Time	Tr, Tf	-	300	700	ps	20% to 80%
Enable and Disable Time	T _{oe}	-	-	115	ns	f = 212.5 MHz - For other frequencies, T _{oe} = 100ns + 3 period
RMS Period Jitter	T _{jitt}	-	1.2	1.7	ps	f = 100 MHz, Vdd = +3.3V or +2.5V
		-	1.2	1.7		f = 156.25 MHz, Vdd = +3.3V or +2.5V
		-	1.2	1.7		f = 212.5 MHz, Vdd = +3.3V or +2.5V
RMS Phase Jitter (random)	T _{phj}	-	0.6	0.85	ps	f = 156.25 MHz, Integration bandwidth = 12 kHz to 20 MHz, all Vdds
LVDS, DC and AC Characteristics						
Current Consumption	I _{dd}	-	+47	+55	mA	Excluding Load Termination Current, Vdd = +3.3V or +2.5V
OE Disable Supply Current	I _{oe}	-	-	+35	mA	OE = Low
Standby Current	I _{std}	-	-	+100	μ A	\overline{ST} = Low, for all Vdds
Rise and Fall Time	Tr, Tf	-	495	700	ps	20% to 80%
Differential Output Voltage	V _{OD}	+250	+350	+450	mV	
V _{OD} Magnitude Change	ΔV_{OD}	-	-	+50	mV	
Offset Voltage	V _{OS}	+1.125	+1.2	+1.375	V	
V _{OS} Magnitude Change	ΔV_{OS}	-	-	+50	mV	
Enable and Disable Time	T _{oe}	-	-	115	ns	f = 212.5 MHz - For other frequencies, T _{oe} = 100ns + 3 period
RMS Period Jitter	T _{jitt}	-	1.2	1.7	ps	f = 100 MHz, Vdd = +3.3V or +2.5V
		-	1.2	1.7		f = 156.25 MHz, Vdd = +3.3V or +2.5V
		-	1.2	1.7		f = 212.5 MHz, Vdd = +3.3V or +2.5V
RMS Phase Jitter (random)	T _{phj}	-	0.6	0.85	ps	f = 156.25 MHz, Integration bandwidth = 12 kHz to 20 MHz, all Vdds
Packing Unit	1000pcs./reel (ϕ 180) or 3000pcs./reel (ϕ 180: 3225 package)					

TC-MO / VC TC-MO - Super Low Jitter

MO5155/MO5156/MO5157/MO5356/MO5357/MO5358/MO5359

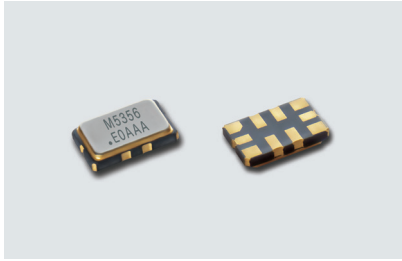

■ Features

- 5.0×3.2 mm Ceramic package
- LVCMOS or Clipped Sinewave output

■ Applications

- Synchronous Ethernet
- Small cell
- Optical transport-SONET/SDH, OTN
- IEEE1588
- Test and measurement



Model	Output Frequency (MHz)	Frequency Tolerance ($\times 10^{-6}$)	Supply Voltage (V)	Current Consumption (mA Typ.)	Size (mm)	Output
MO5155	10 std. GNSS Freq.	$\pm 0.5, \pm 1.0, \pm 2.5$	+2.25 to +3.63	+40 to +50	5.0×3.2×0.95 (Ceramic)	Clipped Sinewave (1 to 60 MHz) LVCMOS
MO5156	1 to 60					
MO5157	60 to 220					
MO5356	1 to 60	$\pm 0.1, \pm 0.2, \pm 0.25$	+2.25 to +3.63	+40 to +50	5.0×3.2×0.95 (Ceramic)	Clipped sinewave, LVCMOS
MO5357	60 to 220					
MO5358	1.0 to 60	± 0.05	+2.25 to +3.63	+40 to +50	5.0×3.2×0.95 (Ceramic)	Clipped sinewave, LVCMOS
MO5359	60 to 189, 200 to 220					

■ Standard Specification (MO5356)

Item	Legend	Min.	Typ.	Max.	Unit	Condition
Output Frequency Range	f	1	-	60	MHz	
Supply Voltage	Vdd	+2.25	+2.50	+2.75	V	
		+2.52	+2.80	+3.08		
		+2.70	+3.00	+3.30		
		+2.97	+3.30	+3.63		
Operating Temperature Range	T _{use}	-20	-	+70	°C	Extended commercial
		-40	-	+85		Industrial
		-40	-	+105		Extended Industrial, ambient temperature
Initial Tolerance	F _{init}	-1.0	-	+1.0	$\times 10^{-6}$	Inclusive of solder-down shift at 48 hours after 2 reflows at +25°C
Frequency Stability over temperature	F _{stab}	-0.10	-	+0.10	$\times 10^{-6}$	Referenced to (f _{mas} + f _{min})/2 over the specified temperature range
		-0.20	-	+0.20		
		-0.25	-	+0.25		
First Year Aging	F _{aging1}	-	± 1.0	-	$\times 10^{-6}$	T _A = +25°C
Pull Range	PR	± 6.25			$\times 10^{-6}$	VC TC-MO mode. Contact KDS for $\pm 12.5, \pm 25$
		$\pm 6.25, \pm 10, \pm 12.5, \pm 25, \pm 50, \pm 80, \pm 100, \pm 125, \pm 150, \pm 200, \pm 400, \pm 600, \pm 800, \pm 1200, \pm 1600, \pm 3200$			$\times 10^{-6}$	DC TC-MO mode.
Upper Control Voltage	VC _U	Vdd×0.9	-	-	V	
Control Voltage Range	VC _L	-	-	Vdd×0.1	V	
Control Voltage Input Impedance	VC _z	8	-	-	MΩ	
Control Voltage Input Bandwidth	VC _c	-	10	-	kHz	
Frequency Change Polarity	-	Positive Slope			-	
Current Consumption	I _{dd}	-	+44	+53	mA	No load condition, f = 19.2 MHz, TC-MO and DC TC-MO mode.
		-	+48	+57		No load condition, f = 19.2 MHz, VC TC-MO mode.
OE Disable Current	I _{od}	-	+43	+51	mA	OE = GND, output is weakly pull down, TC-MO and DC TC-MO mode.
		-	+47	+55		OE = GND, output is weakly pull down, VC TC-MO mode.
Input Low Voltage	V _{IL}	-	-	Vdd×0.3	V	For OE pin
Input High Voltage	V _{HI}	Vdd×0.7	-	-	V	For OE pin
Start-up Time	T _{start}	-	2.5	3.5	ms	Time to first pulse, Measured from the time Vdd reaches its rated minimum value.
RMS Period Jitter	T _{jitt}	-	0.8	1.1	ps	f = 10 MHz
LVCMOS Output						
Duty Cycle	DC	45	-	55	%	
Output Low Voltage	V _{OL}	-	-	Vdd×0.1	V	I _{OL} = -3mA
Output High Voltage	V _{OH}	Vdd×0.9	-	-	V	I _{OH} = +3 mA
Rise and Fall Time	Tr, Tf	0.8	1.2	1.9	ns	10% to 90% Vdd.
RMS Phase Jitter (random)	T _{phj}	-	0.31	0.48	ps	f = 50 MHz, Integration bandwidth = 12 kHz to 20 MHz, -40 to +85 °C
Clipped Sinewave Output						
Output Voltage Level	V _{out}	+0.8	-	+1.2	%	10kΩ 10pF ± 10%
Rise and Fall Time	Tr, Tf	-	3.5	4.6	V	20% to 80% Vdd, 19.2MHz
RMS Phase Jitter (random)	T _{phj}	-	0.31	0.48	ps	f = 60 MHz, Integration bandwidth = 12 kHz to 20 MHz, -40 to +85 °C
Packing Unit	1000pcs./reel (φ 180)					

MEMS Oscillators with Spread Spectrum Function (SSCG)

MO9005

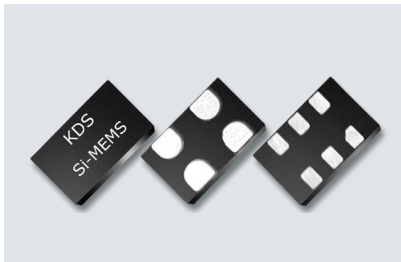

■ Features

- Spread options
Center Spread: $\pm 0.5\%$, $\pm 0.25\%$
Down Spread: -1% , -0.5%
- Standby, output enable or spread disable mode
- <30 ps cycle-to-cycle jitter

■ Applications

- Printers
- Flat panel drivers
- PCI
- Microprocessors



Output Frequency (MHz)	Frequency Tolerance ($\times 10^{-6}$)	Supply Voltage (V)	Current Consumption (mA Typ.)	Size (mm)	Output
1 to 141	± 20 , ± 25 , ± 50	+1.62 to +1.98, +2.25 to +3.63	5.0 to 6.5 (0.4 to 4.3 μ A stby)	2.0 \times 1.6 \times 0.8, 2.5 \times 2.0 \times 0.8, 3.2 \times 2.5 \times 0.8 (QFN)	LVC MOS

■ Standard Specification

Item	Legend	Min.	Typ.	Max.	Unit	Condition
Output Frequency Range	f	1	-	141	MHz	
Supply Voltage	Vdd	+1.62	+1.8	+1.98	V	
		+2.25	+2.5	+2.75		
		+2.52	+2.8	+3.08		
		+2.7	+3.0	+3.3		
		+2.97	+3.3	+3.63		
Operating Temperature Range	T _{use}	-20	-	+70	$^{\circ}$ C	Extended Commercial
		-40	-	+85		Industrial
Frequency Tolerance	F _{tol}	-20	-	+20	$\times 10^{-6}$	Inclusive of initial tolerance at +25 $^{\circ}$ C, 1st year aging at +25 $^{\circ}$ C, and variations over operating temperature, rated power supply voltage.
		-25	-	+25		
		-50	-	+50		
Current Consumption	I _{dd}	-	+5.6	+6.5	mA	No load condition, f = 40 MHz, Vdd = +2.5V to +3.3V
		-	+5.0	+5.5		No load condition, f = 40 MHz, Vdd = +1.8V
Standby Current	I _{std}	-	+2.1	+4.3	μ A	\overline{ST} = GND, Vdd = +2.5V to +3.3V, Output is weakly pulled down
		-	+0.4	+1.5		\overline{ST} = GND, Vdd = +1.8V, Output is weakly pulled down
Spread Spectrum	-	± 0.125 to ± 2.060			%	Center Spread
		-4.28 to -0.25				Down Spread
Duty Cycle	DC	45	-	55	%	
Output Low Voltage	V _{OL}	90%	-	-	Vdd	I _{OH} = -4 mA (Vdd = +3.0V or +3.3V) I _{OH} = -3 mA (Vdd = +2.8V and Vdd = +2.5V) I _{OH} = -2 mA (Vdd = +1.8V)
Output High Voltage	V _{OH}	-	-	10%	Vdd	I _{OL} = +4 mA (Vdd = +3.0V or +3.3V) I _{OL} = +3 mA (Vdd = +2.8V and Vdd = +2.5V) I _{OL} = +2 mA (Vdd = +1.8V)
Rise and Fall Time	Tr, Tf	-	1	2	ns	Vdd = +2.5V, +2.8V, +3.0V or +3.3V, 20% to 80%, default derive strength
		-	1.3	2.5		Vdd = +1.8V, 20% to 80%, default derive strength
		-	-	2.0		Vdd = +2.25V to +3.63V, 20% to 80%, default derive strength
Input Low Voltage	V _{IL}	-	-	Vdd \times 0.3	V	Pin 1, OE or \overline{ST}
Input High Voltage	V _{IH}	Vdd \times 0.7	-	-	V	Pin 1, OE or \overline{ST}
OE Disable Current	I _{oe}	-	+5.0	+6.5	mA	f = 40 MHz, Vdd = +2.5V to +3.3V, OE = GND, Output in high-Z state
		-	+4.6	+5.2		f = 40 MHz, Vdd = +1.8V, OE = GND, Output in high-Z state
Enable/Disable Time	T _{oe}	-	-	180	ns	f = 40 MHz - For other frequencies, T _{oe} = 100ns + 3 period
Packing Unit		1000pcs./reel(ϕ 180)				

Dimensions and Land Pattern

Package Size - Dimensions (unit:mm)	Recommended Land Pattern (unit:mm)														
<p>1.55 × 0.85 mm CSP</p> <p>Pin Connections</p> <table border="1"> <tr><th>Pin No.</th><th>Connection</th></tr> <tr><td>#1</td><td>NC/ST/GND</td></tr> <tr><td>#2</td><td>Output</td></tr> <tr><td>#3</td><td>Vdd</td></tr> <tr><td>#4</td><td>GND</td></tr> </table>	Pin No.	Connection	#1	NC/ST/GND	#2	Output	#3	Vdd	#4	GND	<p>(soldermask openings shown with heavy dashed line)</p>				
Pin No.	Connection														
#1	NC/ST/GND														
#2	Output														
#3	Vdd														
#4	GND														
<p>2.0 × 1.2 mm QFN</p> <p>Pin Connections</p> <table border="1"> <tr><th>Pin No.</th><th>Connection</th></tr> <tr><td>#1</td><td>NC</td></tr> <tr><td>#2</td><td>GND</td></tr> <tr><td>#3</td><td>Output</td></tr> <tr><td>#4</td><td>Vdd</td></tr> </table>	Pin No.	Connection	#1	NC	#2	GND	#3	Output	#4	Vdd					
Pin No.	Connection														
#1	NC														
#2	GND														
#3	Output														
#4	Vdd														
<p>2.0 × 1.6 mm QFN</p> <p>Pin Connections</p> <table border="1"> <tr><th>Pin No.</th><th>Connection</th></tr> <tr><td>#1</td><td>OE/ST/NC/SD</td></tr> <tr><td>#2</td><td>Output</td></tr> <tr><td>#3</td><td>Vdd</td></tr> <tr><td>#4</td><td>GND</td></tr> </table>	Pin No.	Connection	#1	OE/ST/NC/SD	#2	Output	#3	Vdd	#4	GND					
Pin No.	Connection														
#1	OE/ST/NC/SD														
#2	Output														
#3	Vdd														
#4	GND														
<p>2.5 × 2.0 mm QFN 2.7 × 2.4 mm QFN</p> <p>Pin Connections</p> <table border="1"> <tr><th>Pin No.</th><th>Connection</th></tr> <tr><td>#1</td><td>OE/ST/NC/VC/SD</td></tr> <tr><td>#2</td><td>GND</td></tr> <tr><td>#3</td><td>Output</td></tr> <tr><td>#4</td><td>Vdd</td></tr> </table>	Pin No.	Connection	#1	OE/ST/NC/VC/SD	#2	GND	#3	Output	#4	Vdd					
Pin No.	Connection														
#1	OE/ST/NC/VC/SD														
#2	GND														
#3	Output														
#4	Vdd														
<p>3.2 × 2.5 mm QFN (4-pin)</p> <p>Pin Connections</p> <table border="1"> <tr><th>Pin No.</th><th>Connection</th></tr> <tr><td>#1</td><td>OE/ST/NC/VC/SD/DP</td></tr> <tr><td>#2</td><td>GND</td></tr> <tr><td>#3</td><td>Output</td></tr> <tr><td>#4</td><td>Vdd</td></tr> </table>	Pin No.	Connection	#1	OE/ST/NC/VC/SD/DP	#2	GND	#3	Output	#4	Vdd					
Pin No.	Connection														
#1	OE/ST/NC/VC/SD/DP														
#2	GND														
#3	Output														
#4	Vdd														
<p>3.2 × 2.5 mm QFN (6-pin)</p> <p>Pin Connections</p> <table border="1"> <tr><th>Pin No.</th><th>Connection</th></tr> <tr><td>#1</td><td>OE/ST/NC/VC/SD/DP</td></tr> <tr><td>#2</td><td>NC/OE</td></tr> <tr><td>#3</td><td>GND</td></tr> <tr><td>#4</td><td>Output+</td></tr> <tr><td>#5</td><td>Output-</td></tr> <tr><td>#6</td><td>Vdd</td></tr> </table>	Pin No.	Connection	#1	OE/ST/NC/VC/SD/DP	#2	NC/OE	#3	GND	#4	Output+	#5	Output-	#6	Vdd	
Pin No.	Connection														
#1	OE/ST/NC/VC/SD/DP														
#2	NC/OE														
#3	GND														
#4	Output+														
#5	Output-														
#6	Vdd														

Dimensions and Land Pattern

Package Size - Dimensions (unit:mm)	Recommended Land Pattern (unit:mm)																
<p>5.0 × 3.2 mm QFN (4-pin)</p> <p>Pin Connections</p> <table border="1"> <thead> <tr> <th>Pin No.</th> <th>Connection</th> </tr> </thead> <tbody> <tr> <td>#1</td> <td>OE/ST/NC/SD</td> </tr> <tr> <td>#2</td> <td>GND</td> </tr> <tr> <td>#3</td> <td>Output</td> </tr> <tr> <td>#4</td> <td>Vdd</td> </tr> </tbody> </table>	Pin No.	Connection	#1	OE/ST/NC/SD	#2	GND	#3	Output	#4	Vdd							
Pin No.	Connection																
#1	OE/ST/NC/SD																
#2	GND																
#3	Output																
#4	Vdd																
<p>5.0 × 3.2 mm QFN (6-pin)</p> <p>Pin Connections</p> <table border="1"> <thead> <tr> <th>Pin No.</th> <th>Connection</th> </tr> </thead> <tbody> <tr> <td>#1</td> <td>OE/ST/NC/VC/SD/DP</td> </tr> <tr> <td>#2</td> <td>NC/OE/ST</td> </tr> <tr> <td>#3</td> <td>GND</td> </tr> <tr> <td>#4</td> <td>Output+/Output</td> </tr> <tr> <td>#5</td> <td>Output-/NC-</td> </tr> <tr> <td>#6</td> <td>Vdd</td> </tr> </tbody> </table>	Pin No.	Connection	#1	OE/ST/NC/VC/SD/DP	#2	NC/OE/ST	#3	GND	#4	Output+/Output	#5	Output-/NC-	#6	Vdd			
Pin No.	Connection																
#1	OE/ST/NC/VC/SD/DP																
#2	NC/OE/ST																
#3	GND																
#4	Output+/Output																
#5	Output-/NC-																
#6	Vdd																
<p>5.0 × 3.2 mm QFN (6-pin with center pad)</p> <p>Pin Connections</p> <table border="1"> <thead> <tr> <th>Pin No.</th> <th>Connection</th> </tr> </thead> <tbody> <tr> <td>#1</td> <td>OE/NC/VC</td> </tr> <tr> <td>#2</td> <td>OE/NC</td> </tr> <tr> <td>#3</td> <td>GND</td> </tr> <tr> <td>#4</td> <td>Output+</td> </tr> <tr> <td>#5</td> <td>Output-</td> </tr> <tr> <td>#6</td> <td>Vdd</td> </tr> <tr> <td>#7</td> <td>GND</td> </tr> </tbody> </table>	Pin No.	Connection	#1	OE/NC/VC	#2	OE/NC	#3	GND	#4	Output+	#5	Output-	#6	Vdd	#7	GND	
Pin No.	Connection																
#1	OE/NC/VC																
#2	OE/NC																
#3	GND																
#4	Output+																
#5	Output-																
#6	Vdd																
#7	GND																
<p>7.0 × 5.0 mm QFN (4-pin)</p> <p>Pin Connections</p> <table border="1"> <thead> <tr> <th>Pin No.</th> <th>Connection</th> </tr> </thead> <tbody> <tr> <td>#1</td> <td>OE/ST/NC/SD</td> </tr> <tr> <td>#2</td> <td>GND</td> </tr> <tr> <td>#3</td> <td>Output</td> </tr> <tr> <td>#4</td> <td>Vdd</td> </tr> </tbody> </table>	Pin No.	Connection	#1	OE/ST/NC/SD	#2	GND	#3	Output	#4	Vdd							
Pin No.	Connection																
#1	OE/ST/NC/SD																
#2	GND																
#3	Output																
#4	Vdd																
<p>7.0 × 5.0 mm QFN (6-pin)</p> <p>Pin Connections</p> <table border="1"> <thead> <tr> <th>Pin No.</th> <th>Connection</th> </tr> </thead> <tbody> <tr> <td>#1</td> <td>OE/ST/NC/VC/SD/DP</td> </tr> <tr> <td>#2</td> <td>NC/OE/ST</td> </tr> <tr> <td>#3</td> <td>GND</td> </tr> <tr> <td>#4</td> <td>Output+/Output</td> </tr> <tr> <td>#5</td> <td>Output-/NC-</td> </tr> <tr> <td>#6</td> <td>Vdd</td> </tr> </tbody> </table>	Pin No.	Connection	#1	OE/ST/NC/VC/SD/DP	#2	NC/OE/ST	#3	GND	#4	Output+/Output	#5	Output-/NC-	#6	Vdd			
Pin No.	Connection																
#1	OE/ST/NC/VC/SD/DP																
#2	NC/OE/ST																
#3	GND																
#4	Output+/Output																
#5	Output-/NC-																
#6	Vdd																
<p>7.0 × 5.0 mm QFN (6-pin with center pad)</p> <p>Pin Connections</p> <table border="1"> <thead> <tr> <th>Pin No.</th> <th>Connection</th> </tr> </thead> <tbody> <tr> <td>#1</td> <td>OE/NC/VC</td> </tr> <tr> <td>#2</td> <td>OE/NC</td> </tr> <tr> <td>#3</td> <td>GND</td> </tr> <tr> <td>#4</td> <td>Output+</td> </tr> <tr> <td>#5</td> <td>Output-</td> </tr> <tr> <td>#6</td> <td>Vdd</td> </tr> <tr> <td>#7</td> <td>GND</td> </tr> </tbody> </table>	Pin No.	Connection	#1	OE/NC/VC	#2	OE/NC	#3	GND	#4	Output+	#5	Output-	#6	Vdd	#7	GND	<p>(Circles in center part are thermal vias, recommended to improve thermal performance)</p>
Pin No.	Connection																
#1	OE/NC/VC																
#2	OE/NC																
#3	GND																
#4	Output+																
#5	Output-																
#6	Vdd																
#7	GND																

Dimensions and Land Pattern

Package Size - Dimensions (unit:mm)	Recommended Land Pattern (unit:mm)																																																																				
<p>2.9 × 2.8 mm (SOT23-5)</p> <table border="1"> <thead> <tr> <th>Symbol</th> <th>Min.</th> <th>Nom.</th> <th>Max.</th> </tr> </thead> <tbody> <tr><td>A</td><td>0.9</td><td>1.25</td><td>1.45</td></tr> <tr><td>A1</td><td>0</td><td>0.05</td><td>0.15</td></tr> <tr><td>A2</td><td>0.9</td><td>1.1</td><td>1.3</td></tr> <tr><td>b</td><td>0.35</td><td>0.4</td><td>0.5</td></tr> <tr><td>c</td><td>0.08</td><td>0.15</td><td>0.2</td></tr> <tr><td>D</td><td>2.8</td><td>2.9</td><td>3</td></tr> <tr><td>E</td><td>2.6</td><td>2.8</td><td>3</td></tr> <tr><td>E1</td><td>1.5</td><td>1.625</td><td>1.75</td></tr> <tr><td>L</td><td>0.35</td><td>0.45</td><td>0.6</td></tr> <tr><td>L1</td><td colspan="3">0.60 REF</td></tr> <tr><td>e</td><td colspan="3">0.95 BSC.</td></tr> <tr><td>e1</td><td colspan="3">1.90 BSC.</td></tr> <tr><td>α</td><td>0°</td><td>2.5°</td><td>8°</td></tr> </tbody> </table> <p>Pin Connections</p> <table border="1"> <thead> <tr> <th>Pin No.</th> <th>Connection</th> </tr> </thead> <tbody> <tr><td>#1</td><td>GND</td></tr> <tr><td>#2</td><td>NC</td></tr> <tr><td>#3</td><td>OE/NC/ST</td></tr> <tr><td>#4</td><td>Vdd</td></tr> <tr><td>#5</td><td>Output</td></tr> </tbody> </table>	Symbol	Min.	Nom.	Max.	A	0.9	1.25	1.45	A1	0	0.05	0.15	A2	0.9	1.1	1.3	b	0.35	0.4	0.5	c	0.08	0.15	0.2	D	2.8	2.9	3	E	2.6	2.8	3	E1	1.5	1.625	1.75	L	0.35	0.45	0.6	L1	0.60 REF			e	0.95 BSC.			e1	1.90 BSC.			α	0°	2.5°	8°	Pin No.	Connection	#1	GND	#2	NC	#3	OE/NC/ST	#4	Vdd	#5	Output	
Symbol	Min.	Nom.	Max.																																																																		
A	0.9	1.25	1.45																																																																		
A1	0	0.05	0.15																																																																		
A2	0.9	1.1	1.3																																																																		
b	0.35	0.4	0.5																																																																		
c	0.08	0.15	0.2																																																																		
D	2.8	2.9	3																																																																		
E	2.6	2.8	3																																																																		
E1	1.5	1.625	1.75																																																																		
L	0.35	0.45	0.6																																																																		
L1	0.60 REF																																																																				
e	0.95 BSC.																																																																				
e1	1.90 BSC.																																																																				
α	0°	2.5°	8°																																																																		
Pin No.	Connection																																																																				
#1	GND																																																																				
#2	NC																																																																				
#3	OE/NC/ST																																																																				
#4	Vdd																																																																				
#5	Output																																																																				
<p>5.0 × 3.2 mm (Ceramic)</p> <p>Pin Connections</p> <table border="1"> <thead> <tr> <th>Pin No.</th> <th>Connection</th> </tr> </thead> <tbody> <tr><td>#1</td><td>OE/NC/Vc</td></tr> <tr><td>#2</td><td>NC</td></tr> <tr><td>#3</td><td>NC</td></tr> <tr><td>#4</td><td>GND</td></tr> <tr><td>#5</td><td>NC</td></tr> <tr><td>#6</td><td>#6 Output</td></tr> <tr><td>#7</td><td>NC</td></tr> <tr><td>#8</td><td>NC</td></tr> <tr><td>#9</td><td>Vdd</td></tr> <tr><td>#10</td><td>NC</td></tr> </tbody> </table>	Pin No.	Connection	#1	OE/NC/Vc	#2	NC	#3	NC	#4	GND	#5	NC	#6	#6 Output	#7	NC	#8	NC	#9	Vdd	#10	NC																																															
Pin No.	Connection																																																																				
#1	OE/NC/Vc																																																																				
#2	NC																																																																				
#3	NC																																																																				
#4	GND																																																																				
#5	NC																																																																				
#6	#6 Output																																																																				
#7	NC																																																																				
#8	NC																																																																				
#9	Vdd																																																																				
#10	NC																																																																				

Taping Forms, etc.

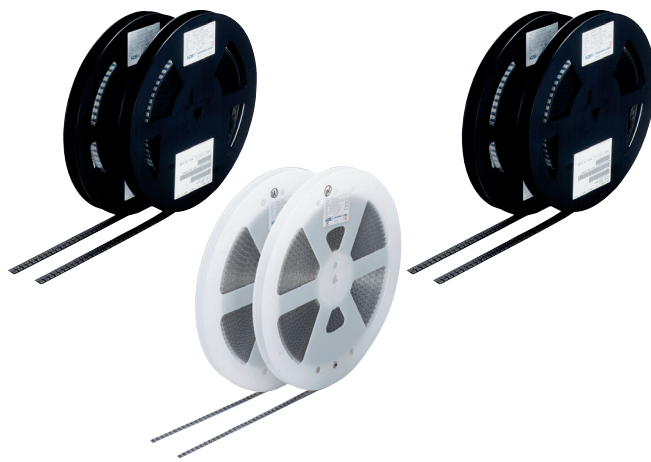

Emboss Carrier Tape (SMD Crystal Resonators)

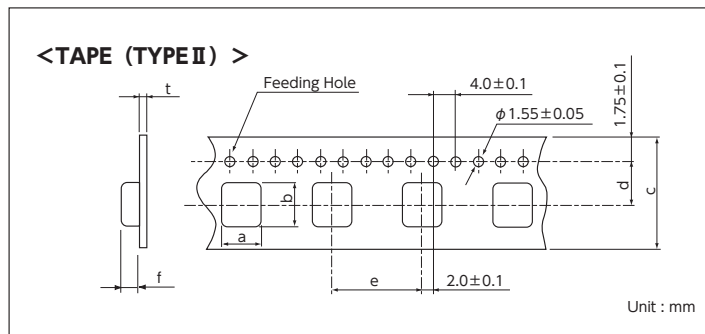
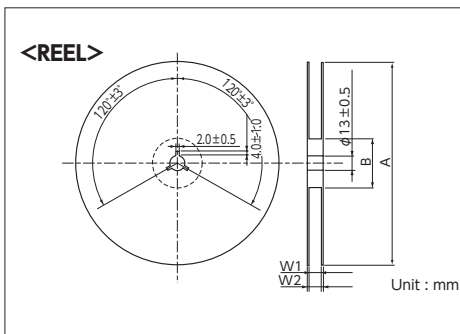
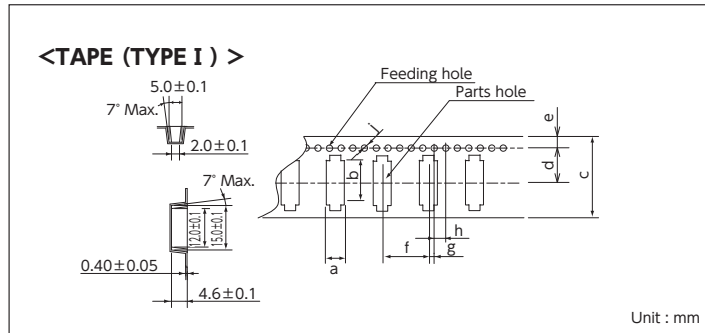

Standard Specification

MHz Band Crystal Resonators / Crystal Resonators with dedicated temperature sensor

TYPE II	a	b	c	d	e	f	t	A	B	W1	W2
DSX530GA	3.6 ±0.1	5.45 ±0.10	12.0 ±0.2	5.50 ±0.10	8.0 ±0.1	1.55 ±0.10	0.30 ±0.05	φ180 +0/-3	φ60 +1.0/-0	13.0 ±0.3	15.4 ±1.0
DSX321G/GK DSX320GE	2.8 ±0.1	3.5 ±0.1	8.0 ±0.2	3.50 ±0.05	4.0 ±0.1	1.0 ±0.1	0.25 ±0.05	φ180 +0/-3	φ60 +1/-0	9.0 ±0.3	11.4 ±1.0
DSX321SH	2.7 ±0.1	3.4 ±0.1	8.0 ±0.2	3.50 ±0.05	4.0 ±0.1	1.4 ±0.1	0.25 ±0.05	φ180 +0/-3	φ60.0 +1/-0	9.0 ±0.3	11.4 ±1.0
DSX221SH	2.25 ±0.1	2.7 ±0.1	8.0 ±0.2	3.50 ±0.05	4.0 ±0.1	0.8 ±0.05	0.25 ±0.05	φ180 +0/-3	φ60.0 +1/-0	9.0 ±0.3	11.4 ±1.0
DSX211S/SH	1.9 ±0.1	2.3 ±0.1	8.0 ±0.2	3.50 ±0.05	4.0 ±0.1	0.65 ±0.10	0.25 ±0.05	φ180 +0/-3	φ60.0 +1/-0	9.0 ±0.3	11.4 ±1.0
DSX211G	1.85 ±0.10	2.25 ±0.10	8.0 ±0.2	3.50 ±0.05	4.0 ±0.1	0.95 ±0.10	0.25 ±0.05	φ180 +0/-3	φ60 +1/-0	9.0 ±0.3	11.4 ±1.0
DSX210GE	2.0 ±0.1	2.4 ±0.1	8.0 ±0.2	3.50 ±0.05	4.0 ±0.1	0.95 ±0.1	0.25 ±0.05	φ180 +0/-3	φ60 +1/-0	9.0 ±0.3	11.4 ±1.0
DSX1612S	1.45 ±0.15	1.85 ±0.15	8.0 ±0.2	3.50 ±0.05	4.0 ±0.1	0.45 ±0.15	0.25 ±0.05	φ180 +0/-3	φ60 +1/-0	9.0 ±0.3	11.4 ±1.0
DSX1210A	1.17 ±0.05	1.42 ±0.05	8.0 +0.3/-0.1	3.50 ±0.05	4.0 ±0.1	0.48 ±0.05	0.20 ±0.05	φ180 +0/-3	φ60 +1/-0	9.0 ±0.3	11.4 ±1.0
DX1008JS/JT	1.0 ±0.05	1.2 ±0.05	8.0 ±0.2	3.50 ±0.05	4.0 ±0.1	0.45 ±0.05	0.20 ±0.05	φ180 +0/-3	φ60 +1/-0	9.0 ±0.3	11.4 ±1.0
DSR221STH	2.25 ±0.1	2.7 ±0.1	8.0 ±0.2	3.50 ±0.05	4.0 ±0.1	1.15 ±0.10	0.25 ±0.05	φ180 +0/-3	φ60 +1/-0	9.0 ±0.3	11.4 ±1.0
DSR211STH	1.9 ±0.1	2.3 ±0.1	8.0 ±0.2	3.50 ±0.05	4.0 ±0.1	0.85 ±0.10	0.25 ±0.05	φ180 +0/-3	φ60 +1/-0	9.0 ±0.3	11.4 ±1.0
DSR1612ATH	1.40 ±0.1	1.80 ±0.1	8.0 ±0.2	3.50 ±0.05	4.0 ±0.1	0.70 ±0.10	0.25 ±0.05	φ180 +0/-3	φ60 +1/-0	9.0 ±0.3	11.4 ±1.0
DSR1210ATH	1.3 ±0.1	1.5 ±0.1	8.0 ±0.2	3.5 ±0.05	4.0 ±0.1	0.65 ±0.01	0.25 ±0.05	φ180 +0/-3	φ60 +1/-0	9.0 ±0.3	11.4 ±1.0

kHz Band Crystal Resonators

DST310SA	1.70 ±0.05	3.40 ±0.05	12.0 ±0.2	5.50 ±0.05	4.0 ±0.1	0.95 ±0.05	0.25 ±0.05	φ180 +0/-3	φ60 +1/-0	13.0 ±0.3	15.5 ±1.0
DST210AC	1.45 ±0.1	2.3 ±0.1	8.0 ±0.2	3.50 ±0.05	4.0 ±0.1	0.65 ±0.10	0.20 ±0.05	φ180 +0/-3	φ60 +1/-0	9.0 ±0.3	11.4 ±1.0
DST1610A	1.28 ±0.05	1.79 ±0.05	8.0 +0.3/-0.1	3.50 ±0.05	4.0 ±0.1	0.65 ±0.10	0.20 ±0.05	φ180 +0/-3	φ60 +1/-0	9.0 ±0.3	11.4 ±1.0
DST1210A	1.17 ±0.05	1.42 ±0.05	8.0 +0.3/-0.1	3.50 ±0.05	4.0 ±0.1	0.48 ±0.05	0.20 ±0.05	φ180 +0/-3	φ60 +1/-0	9.0 ±0.3	11.4 ±1.0

※1: To indicate product name and other information, place those information on a label, and affix the label on one side of the flange.

2: For DSX321G, DSX1612S pin No.1 is located on the sprocket-hole side of the tape.

3: For other models, the insertion direction is not specified.

Emboss Carrier Tape (SMD Crystal Oscillators)

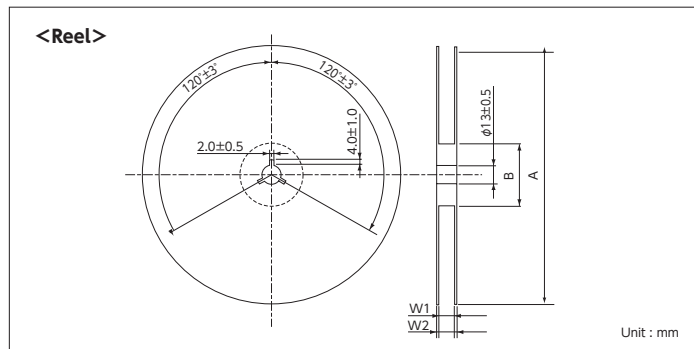
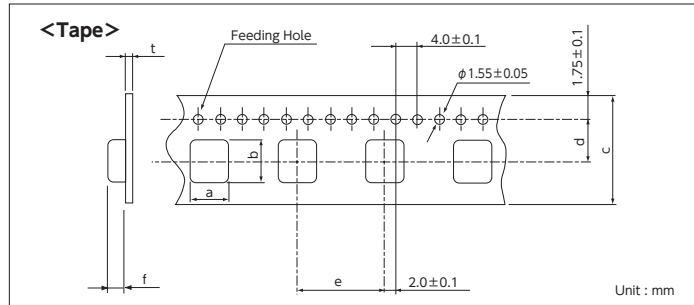

Standard Specification

VC-TCXO/TCXO

TYPE	a	b	c	d	e	f	t	A	B	W1	W2
DSA/DSB535SGA DSA535SGB	3.5 ±0.1	5.4 ±0.1	12.0 ±0.2	5.50 ±0.1	8.0 ±0.1	1.7 ±0.1	0.30 ±0.05	φ330 ±2	φ100 ±1	13.5 ±1.0	18.5 max.
DSA/DSB321SDN DSK321STD	2.8 ±0.1	3.5 ±0.1	8.0 ±0.2	3.50 ±0.05	4.0 ±0.1	1.5 ±0.1	0.25 ±0.05	φ180 +0/-3	φ60 +1/-0	9.0 ±0.3	11.4 ±1.0
DSA/DSB221SDN DSB221SJA	2.3 ±0.1	2.8 ±0.1	8.0 ±0.2	3.50 ±0.05	4.0 ±0.1	1.15 ±0.1	0.30 ±0.05	φ180 +0/-3	φ60 +1/-0	9.0 ±0.3	11.4 ±1.0
DA/DB2016AS DSA/DSB211SDN/SP DSB211SJA	1.95 ±0.10	2.35 ±0.10	8.0 ±0.2	3.50 ±0.05	4.0 ±0.1	0.85 ±0.1	0.20 ±0.05	φ180 +0/-3	φ60 +1/-0	9.0 ±0.3	11.4 ±1.0
DSA/DSB1612SDN DSB1612SEB	1.4 ±0.10	1.8 ±0.10	8.0 ±0.2	3.50 ±0.05	4.0 ±0.1	0.7 ±0.1	0.25 ±0.05	φ180 +0/-3	φ60 +1/-0	9.0 ±0.3	11.4 ±1.0
DSK1612ATD	1.45 ±0.10	1.8 ±0.1	8.0 ±0.2	3.50 ±0.05	4.0 ±0.1	0.75 ±0.10	0.25 ±0.05	φ180 +0/-3	φ60 +1/-0	9.0 ±0.3	11.4 ±1.0

SPXO/VCXO/RTC

TYPE	a	b	c	d	e	f	t	A	B	W1	W2
DSO751SR/SBM DSO753SK/SJ/SD	5.5 ±0.1	7.9 ±0.1	16.0 ±0.3	7.5 ±0.1	8.0 ±0.1	2.4 ±0.1	0.30 ±0.05	φ254 ±2	φ80 ±0.5	17.0 ±0.5	21.0 ±1.0
DSO531SR/SBM DSO533SK/SJ	3.6 ±0.1	5.45 ±0.1	12.0 ±0.2	5.50 ±0.05	8.0 ±0.1	1.55 ±0.10	0.30 ±0.05	φ180 +0/-3	φ60 +1/-0	13.0 ±0.3	15.4 ±1.0
DD3225TR/TS DS3225AD/AJ/AK DSO321SH/SR/SY/SBM/SHH/SRS DSO323SD/SJ/SK DSV321SV	2.8 ±0.1	3.5 ±0.1	8.0 ±0.2	3.50 ±0.05	4.0 ±0.1	1.5 ±0.1	0.25 ±0.05	φ180 +0/-3	φ60 +1/-0	9.0 ±0.3	11.4 ±1.0
DS2520AD/AJ/AK/AS DSO221SH/SR/SX/SY/SBM/SHH/SXF DSO223SD/SJ/SK DSV221SV	2.3 ±0.1	2.8 ±0.1	8.0 ±0.2	3.50 ±0.05	4.0 ±0.1	1.15 ±0.10	0.30 ±0.05	φ180 +0/-3	φ60 +1/-0	9.0 ±0.3	11.4 ±1.0
DS2016AD/AJ/AK/AS DSO211SX/SXF	1.85 ±0.10	2.25 ±0.10	8.0 ±0.2	3.50 ±0.05	4.0 ±0.1	0.95 ±0.10	0.25 ±0.05	φ180 +0/-3	φ60 +1/-0	9.0 ±0.3	11.4 ±1.0
DSO1612AR	1.4 ±0.1	1.8 ±0.1	8.0 ±0.2	3.50 ±0.05	4.0 ±0.1	0.7 ±0.1	0.25 ±0.05	φ180 +0/-3	φ60 +1/-0	9.0 ±0.3	11.4 ±1.0
DS1008JC/JJ/JK/JN/JS	1.0 ±0.05	1.2 ±0.05	8.0 ±0.2	3.50 ±0.05	4.0 ±0.1	0.45 ±0.05	0.20 ±0.05	φ180 +0/-3	φ60 +1/-0	9.0 ±0.3	11.4 ±1.0

* 1: To indicate product name and other information, place those information on a label, and affix the label on one side of the flange.
 2: DSA/DSB535SGA, DSA535SGB: reel φ180 available.

Radial Tape (Crystal Oscillators)

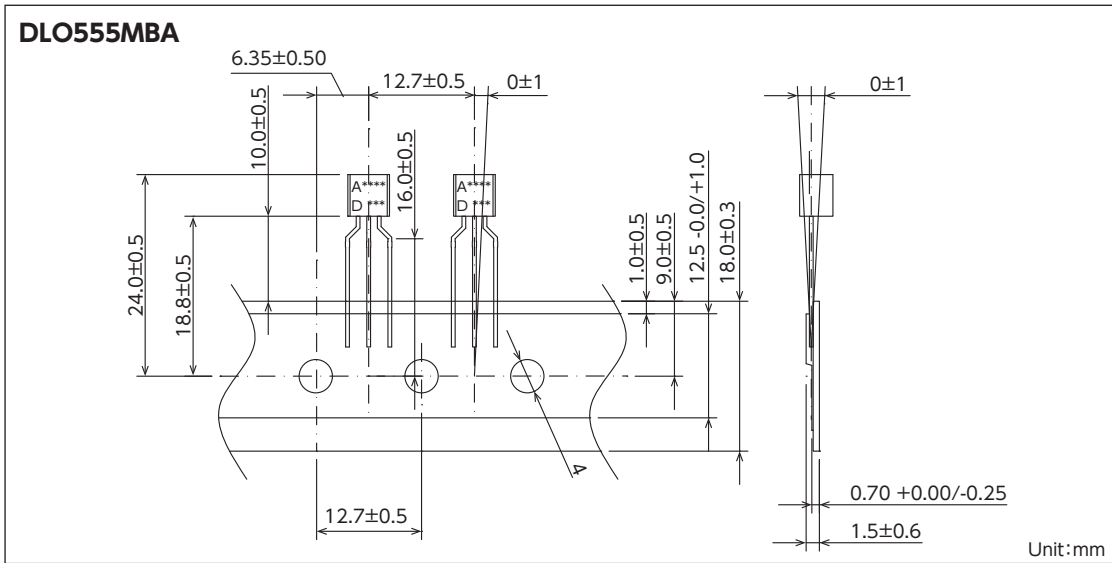

Emboss Carrier Tape (SMD Monolithic Crystal Filters)

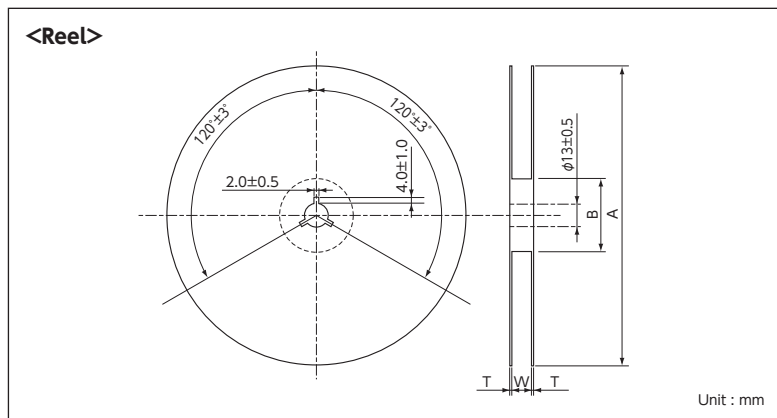
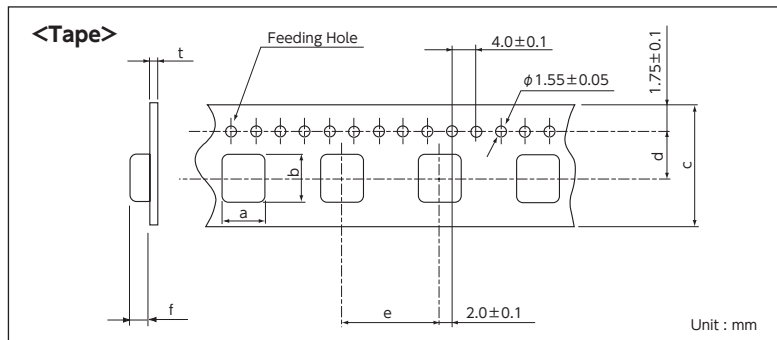

Standard Specification

TYPE	a	b	c	d	e	f	t	A	B	T	W
DSF753S SERIES	5.6 ±0.1	7.6 ±0.1	16.0 ±0.3	7.5 ±0.1	8.0 ±0.1	1.7 ±0.1	0.30 ±0.05	φ178 ±2	φ60 +1/-0	1.2 ±0.5	17.0 ±0.3
DSF633S SERIES	4.0 ±0.1	6.5 ±0.1	12.0 ±0.2	5.5 ±0.05	8.0 ±0.1	1.7 ±0.1	0.30 ±0.05	φ178 ±2	φ60 ±1/-0	1.2 ±0.5	13.0 ±0.3
DSF444S SERIES	4.0 ±0.1	4.0 ±0.1	12.0 ±0.3	5.5 ±0.1	8.0 ±0.1	1.5 ±0.1	0.30 ±0.05	φ178 ±2	φ60 ±1/-0	1.2 ±0.5	13.0 ±0.3
DSF334S SERIES	3.2 ±0.1	3.2 ±0.1	8.0 ±0.2	3.5 ±0.05	4.0 ±0.1	1.5 ±0.1	0.25 ±0.05	φ178 ±2	φ60 +1/-0	1.2 ±0.5	9.0 ±0.3

※ 1: To indicate product name and other information, place those information on a label, and affix the label on one side of the flange.
 2: The taping dimensions should be as per JIS C 0806. 1,000 units should be packaged per reel.
 3: The standard packaged quantity per reel is 2,000 units for DSF334S.

Emboss Carrier Tape (MEMS Oscillators)

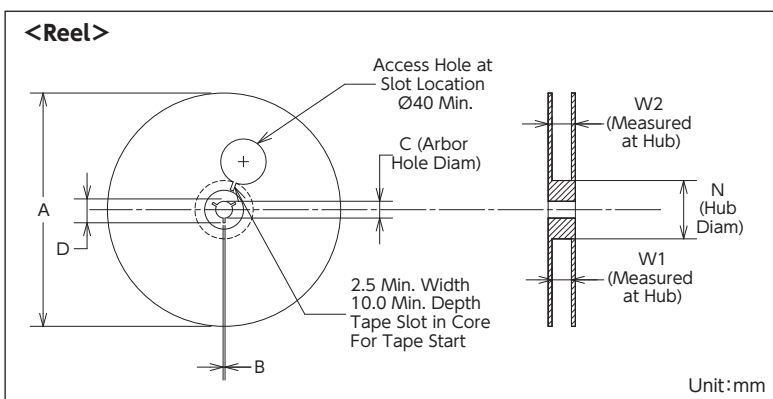
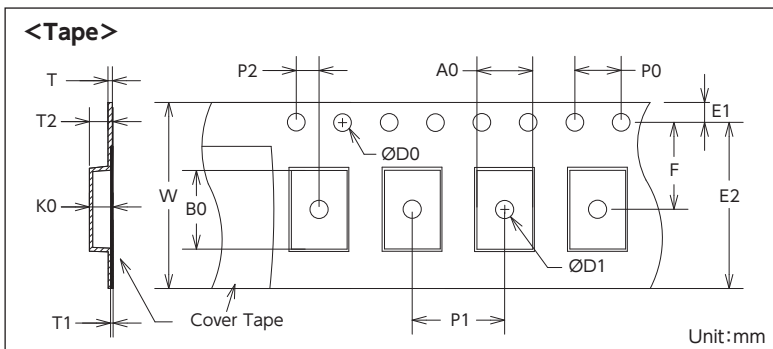
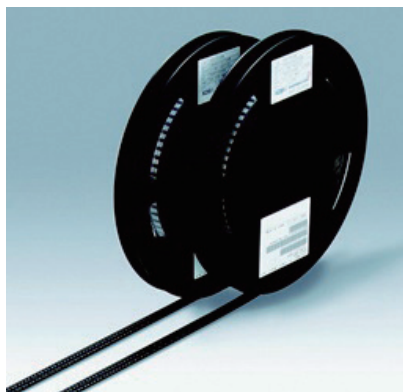

Reel Standard Specification

Tape Size	A Max.	B Min.	C	D Min.	N	W1	W2 Max.
8	180	1.5	13.0 +0.6/-0.2	20.2	60 +0.5/-0.5	8.4 +1.5/-0	14.4
8	330	1.5	13.0 +0.2/-0.2	20.2	100 +0.5/-0.5	8.4 +1.5/-0	14.4
12	330	1.5	13.0 +0.2/-0.2	20.2	100 +0.5/-0.5	12.4 +2.0/-0	18.4
12	180	1.5	13.0 +0.2/-0.2	20.2	60 +0.5/-0.5	12.4 +2.0/-0	18.4
16	330	1.5	13.0 +0.2/-0.2	20.2	100 +0.5/-0.5	16.4 +2.0/-0	22.4
16	180	1.5	13.0 +0.2/-0.2	20.2	60 +0.5/-0.5	16.4 +2.0/-0	22.4

Carrier Tape Standard Specification

Package Outline Drawing	Package Size	Tape Size	D0	D1 Min.	E1	E2 Min.	F	P0	P1	P2	T	T1 Max.	T2 Max.	W Max.	A0	B0	K0
POD-1	2.5×2.0×0.75	12	1.5 +0.1/-0.0	1.5	1.75 ±0.1	10.25	5.5 ±0.05	4.0 ±0.1	4.0 ±0.1	2.0 ±0.05	0.6	0.1	1.65	12.3	2.3 ±0.10	2.8 ±0.10	1.10 ±0.10
POD-1	2.5×2.0×0.75	8	1.55 ±0.05	1.0	1.75 ±0.1	5.85	3.5 ±0.05	4.0 ±0.1	4.0 ±0.1	2.0 ±0.05	0.3 ±0.05	0.1	1.65	8.3	2.25 ±0.05	2.8 ±0.05	1.10 ±0.10
POD-23	2.7×2.4×0.75	12	1.55 ±0.05	1.0	1.75 ±0.1	9.85	5.5 ±0.05	4.0 ±0.1	4.0 ±0.1	2.0 ±0.05	0.3 ±0.05	0.1	1.55	12.3	2.65 ±0.10	2.95 ±0.10	1.00 ±0.10
POD-23	2.7×2.4×0.75	8	1.55 ±0.05	1.0	1.75 ±0.1	5.85	3.5 ±0.05	4.0 ±0.1	4.0 ±0.1	2.0 ±0.05	0.3 ±0.05	0.1	1.55	8.3	2.65 ±0.10	2.95 ±0.10	1.00 ±0.10
POD-2	3.2×2.5×0.75	12	1.5 +0.1/-0.0	1.5	1.75 ±0.1	10.25	5.5 ±0.05	4.0 ±0.1	4.0 ±0.1	2.0 ±0.05	0.6	0.1	1.65	12.3	2.8 ±0.10	3.5 ±0.10	1.10 ±0.10
POD-2	3.2×2.5×0.75	8	1.5 +0.1/-0.0	1.0	1.75 ±0.1	5.95	3.5 ±0.05	4.0 ±0.1	4.0 ±0.1	2.0 ±0.05	0.2 ±0.05	0.1	1.65	8.2	2.7 ±0.10	3.4 ±0.10	1.15 ±0.10
POD-3	5.0×3.2×0.75	12	1.5 +0.1/-0.0	1.5	1.75 ±0.1	10.25	5.5 ±0.05	4.0 ±0.1	8.0 ±0.1	2.0 ±0.05	0.6	0.1	1.65	12.3	3.5 ±0.10	5.3 ±0.10	1.10 ±0.10
POD-4	7.0×5.0×0.90	16	1.5 +0.1/-0.0	1.5	1.75 ±0.1	14.25	7.5 ±0.10	4.0 ±0.1	8.0 ±0.1	2.0 ±0.10	0.6	0.1	1.80	16.3	5.4 ±0.10	7.4 ±0.10	1.3 ±0.10
POD-9	3.5×3.0×0.30	12	1.5 +0.1/-0.0	1.5	1.75 ±0.1	10.25	5.5 ±0.05	4.0 ±0.1	8.0 ±0.1	2.0 ±0.05	0.6	0.1	1.65	12.3	3.3 ±0.10	3.8 ±0.10	0.65 ±0.10
POD-26	2.0×1.6×0.75	8	1.55 ±0.05	0.9	1.75 ±0.1	6.05	3.5 ±0.05	4.0 ±0.1	4.0 ±0.1	2.0 ±0.05	0.3 ±0.05	0.1	1.55	8.3	1.9 ±0.05	2.3 ±0.05	1.00 ±0.10
POD-29	2.0×1.2×0.60	8	1.55 ±0.05	1.0	1.75 ±0.1	6.05	3.5 ±0.05	4.0 ±0.1	4.0 ±0.1	2.0 ±0.05	0.25 ±0.05	0.1	1.55	8.3	1.9 ±0.05	2.3 ±0.05	1.00 ±0.10
POD-32	1.5×0.8×0.60	8	1.55 ±0.05	0.18	1.75 ±0.1	6.05	3.5 ±0.05	4.0 ±0.1	4.0 ±0.1	2.0 ±0.05	0.2 ±0.02	0.1	1.55	8.3	0.96 ±0.03	1.66 ±0.03	0.63 ±0.03
SOT-23	2.8×1.6×1.45	8	1.55 ±0.05	1.0	1.75 ±0.1	6.05	3.5 ±0.05	4.0 ±0.1	4.0 ±0.1	2.0 ±0.05	0.25 ±0.02	0.1	1.62	8.3	3.23 ±0.10	3.17 ±0.10	1.37 ±0.10

Refer to datasheet for details of emboss carrier tape specifications.

Measurement Circuit (Crystal Oscillators)

VC-TCXO (DA2016AS, DSA***SDN, SP)

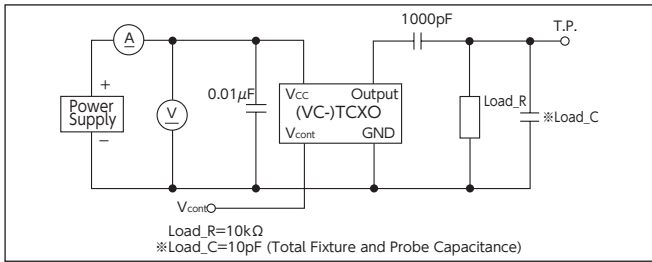

TCXO (DB2016AS, DSB***SDN, SP)

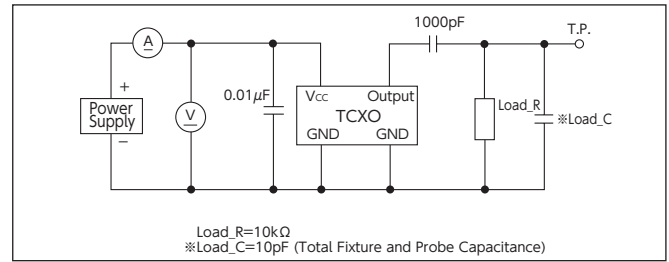

DSA535SGA, DSA535SGB (Clipped Sine)

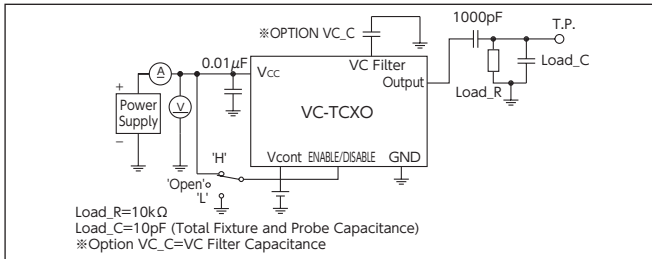

DSA535SGA, DSA535SGB (CMOS)

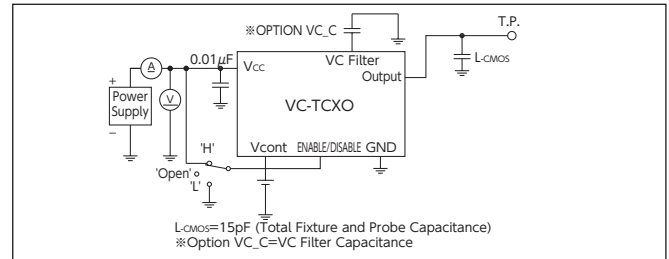

DSB535SGA (Clipped Sine)

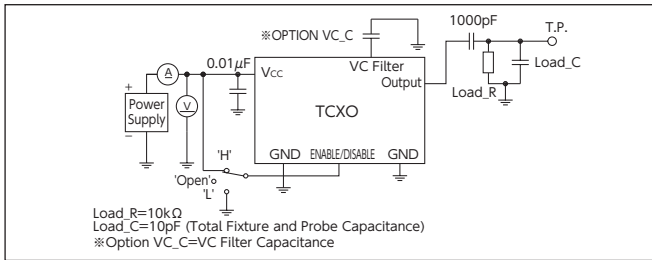

DSB535SGA (CMOS)

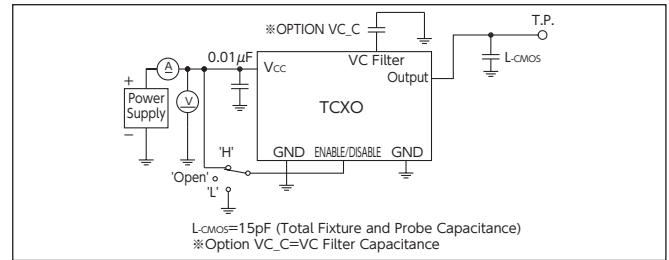

DSB1612SEB

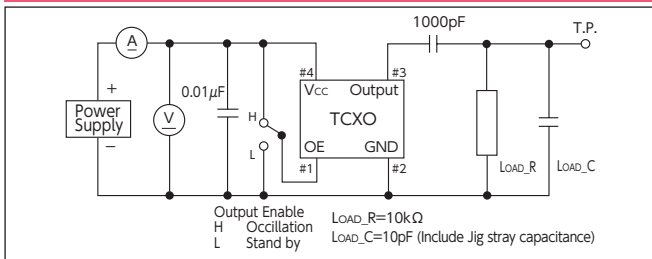

DSB211SJA, 221SJA

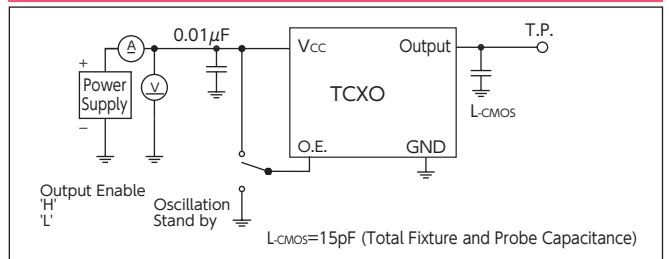

DSK1612ATD

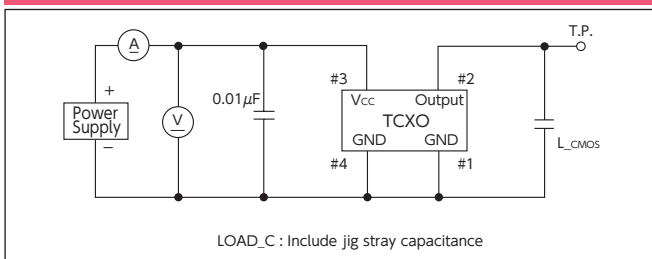

DSK321STD

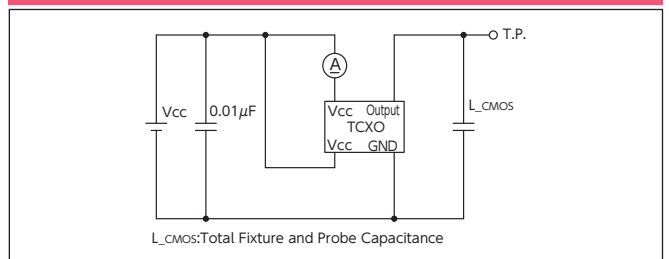

DD3225TS

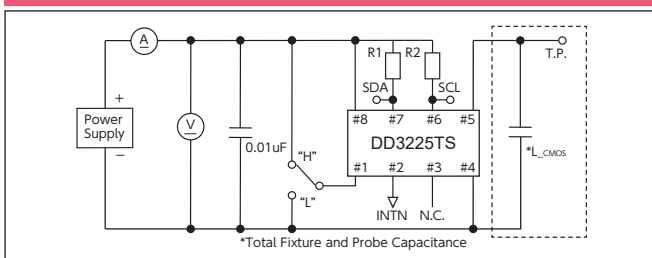

DD3225TR

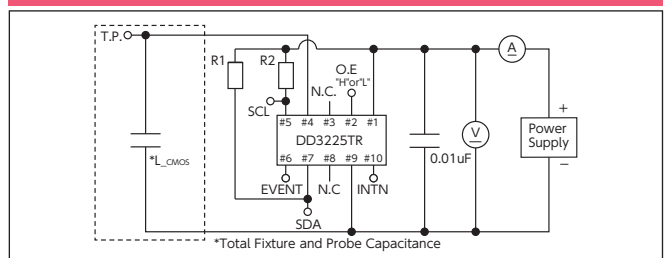

Measurement Circuit (Crystal Oscillators)

DS1008JS, JN, DSO*AR, SR, SH, SY, SRS, SBM, SHH**

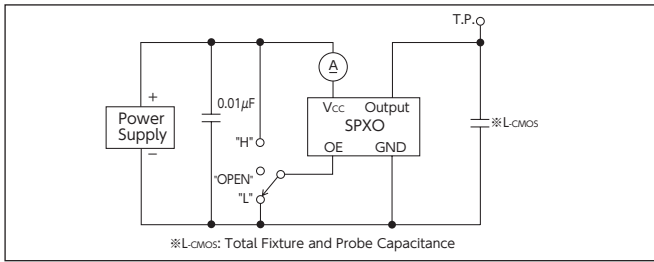

DS*AS, DSO***SX, SXF**

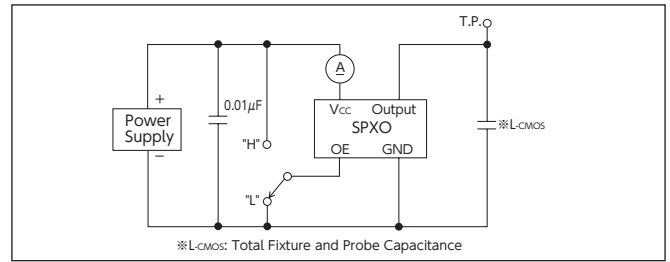

DS1008JC

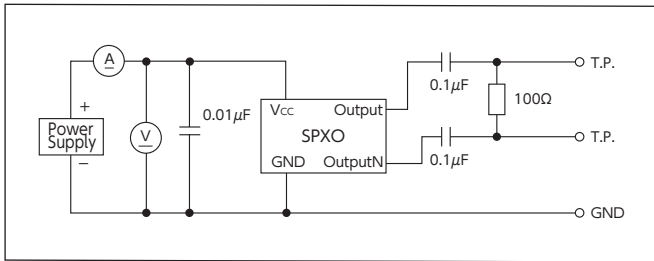

DS1008JK

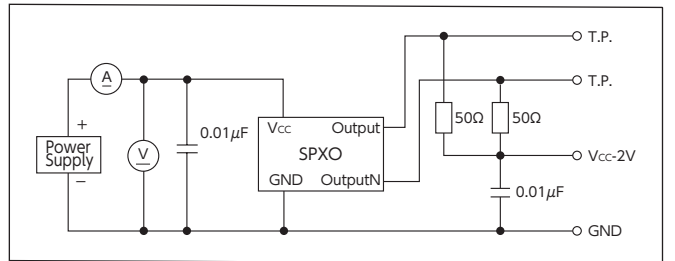

DS1008JJ

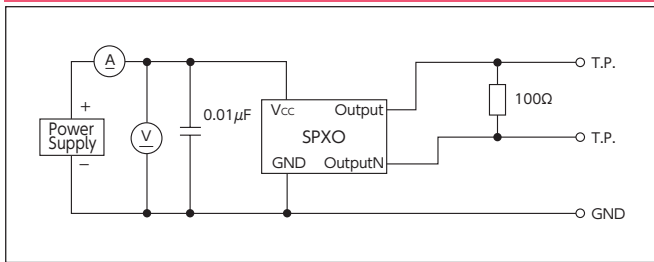

DS*AJ, DSO***SJ**

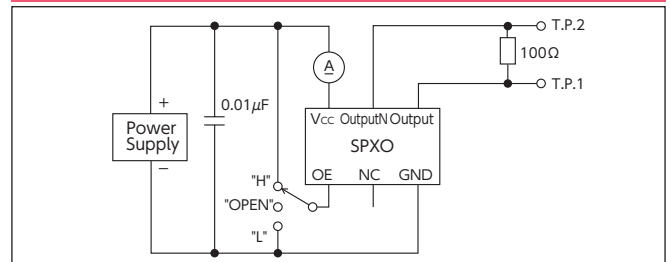

DS*AK, DSO***SK**

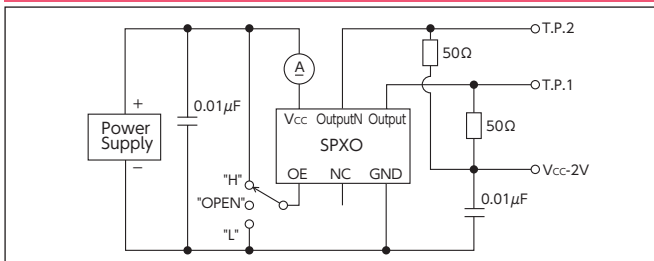

DS*AD, DSO***SD**

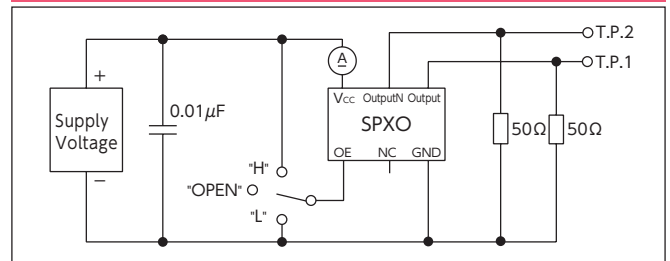

DLO55MBA

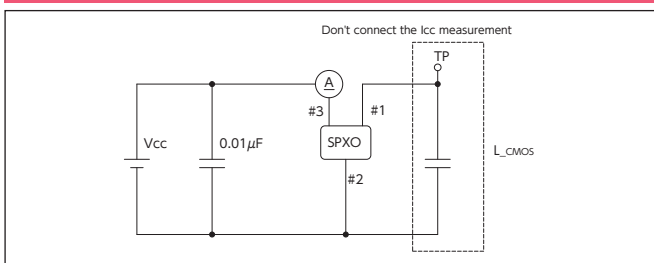

DSV221SV, 321SV

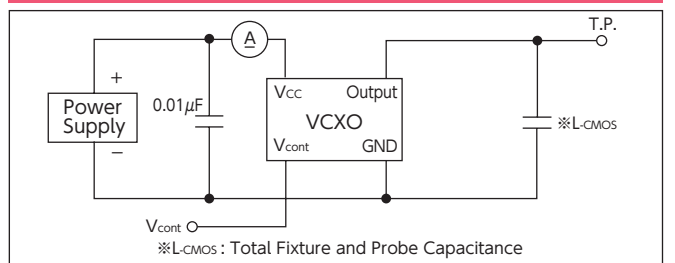

Measurement Circuit

Output Wave Form

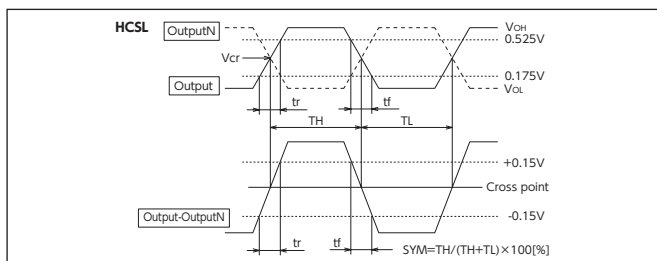
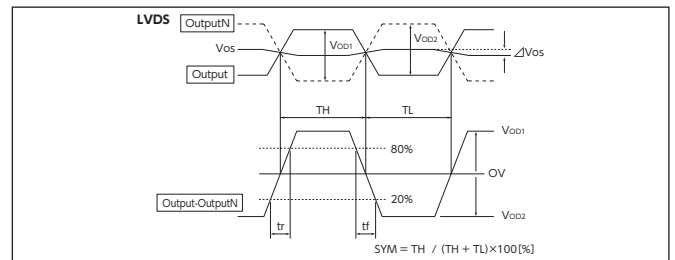
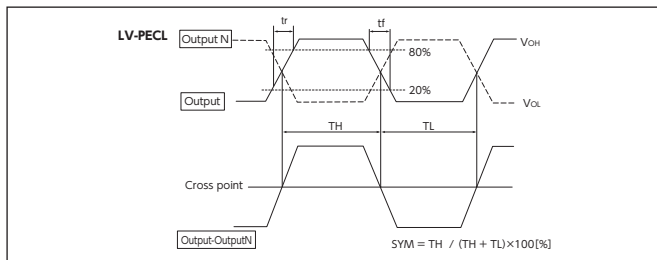
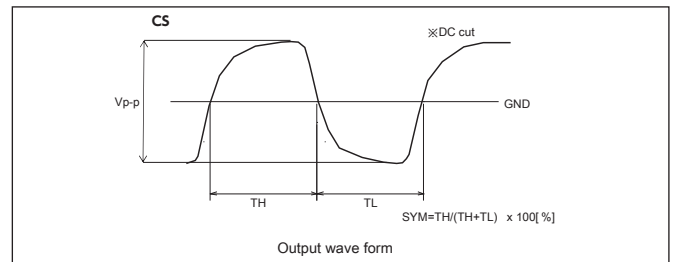
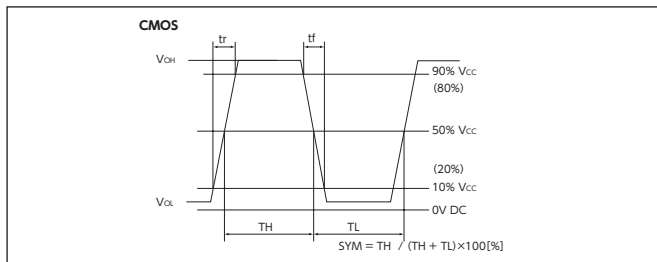

Input and Output Conditions

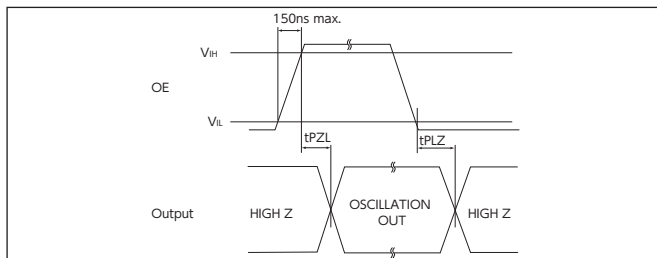

Measurement Circuit (MEMS Oscillators)

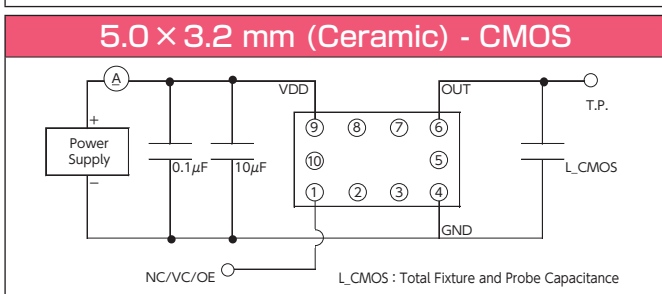
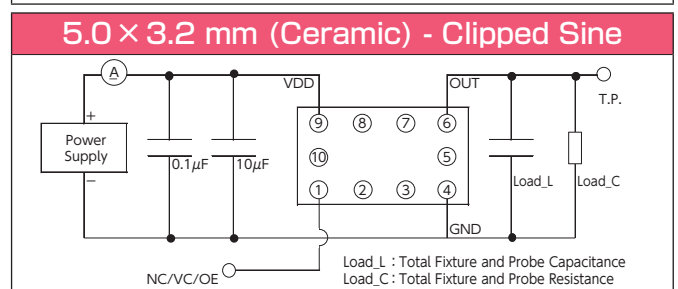
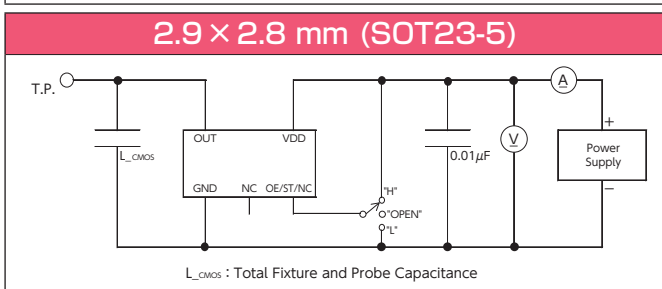
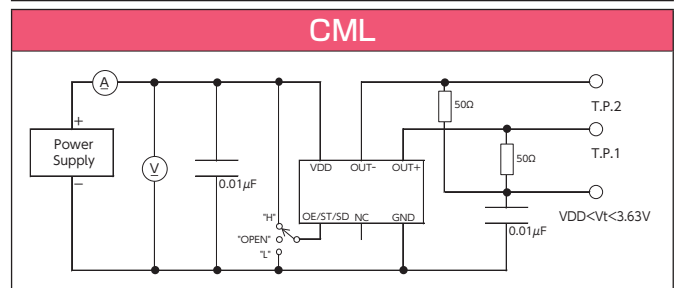
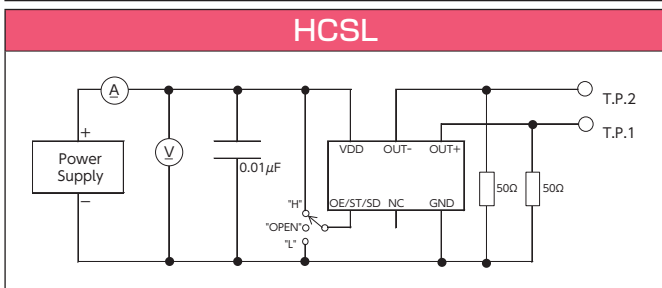
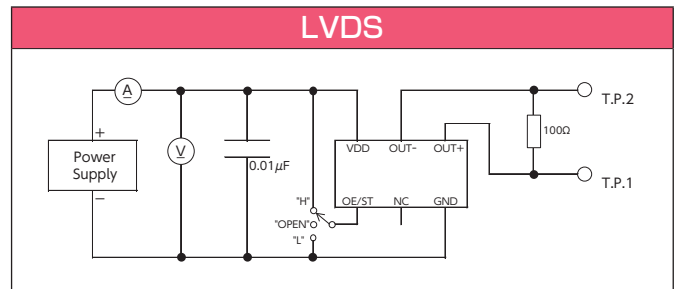
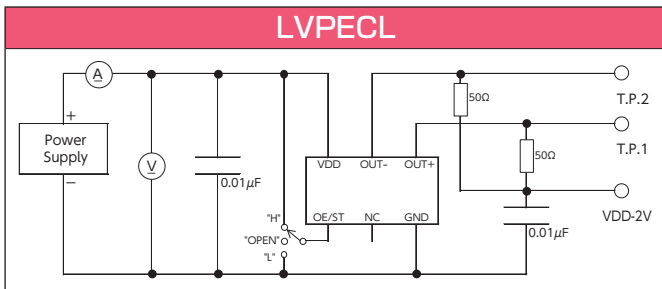
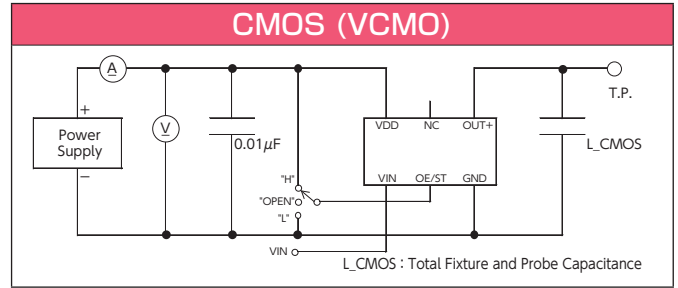
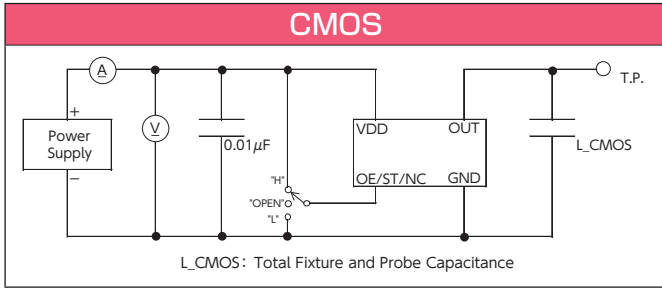

Substitution Products

Please contact our sales representative for further assistance.
 You may also visit our web site (<https://www.kds.info>) to obtain standard specification.



SMD Tuning Fork Crystal Resonators	
Type	Substitution Products
DST310S	DST310SA
DMX-26S	DST1610A, DST210AC, DST310SA

Tuning Fork Crystal Resonators	
Type	Substitution Products
DT-26	DST310SA
DT-261	DST1610A, DST210AC, DST310SA
DT-38	DST310SA
DT-381	DST1610A, DST210AC, DST310SA

SMD Crystal Resonators <For Automotive>	
Type	Substitution Products
DST310S	DST310SA
DMX-26S	DST1610A, DST210AC, DST310SA

MEMS Oscillators	
Type	Substitution Products
MO9002	—
MO9003	—

Product introduction on the Web

Sending products information through Internet

DAISHINKU has been supplying the latest products information through Internet. Please use this service.
DAISHINKU Web site: <https://www.kds.info>

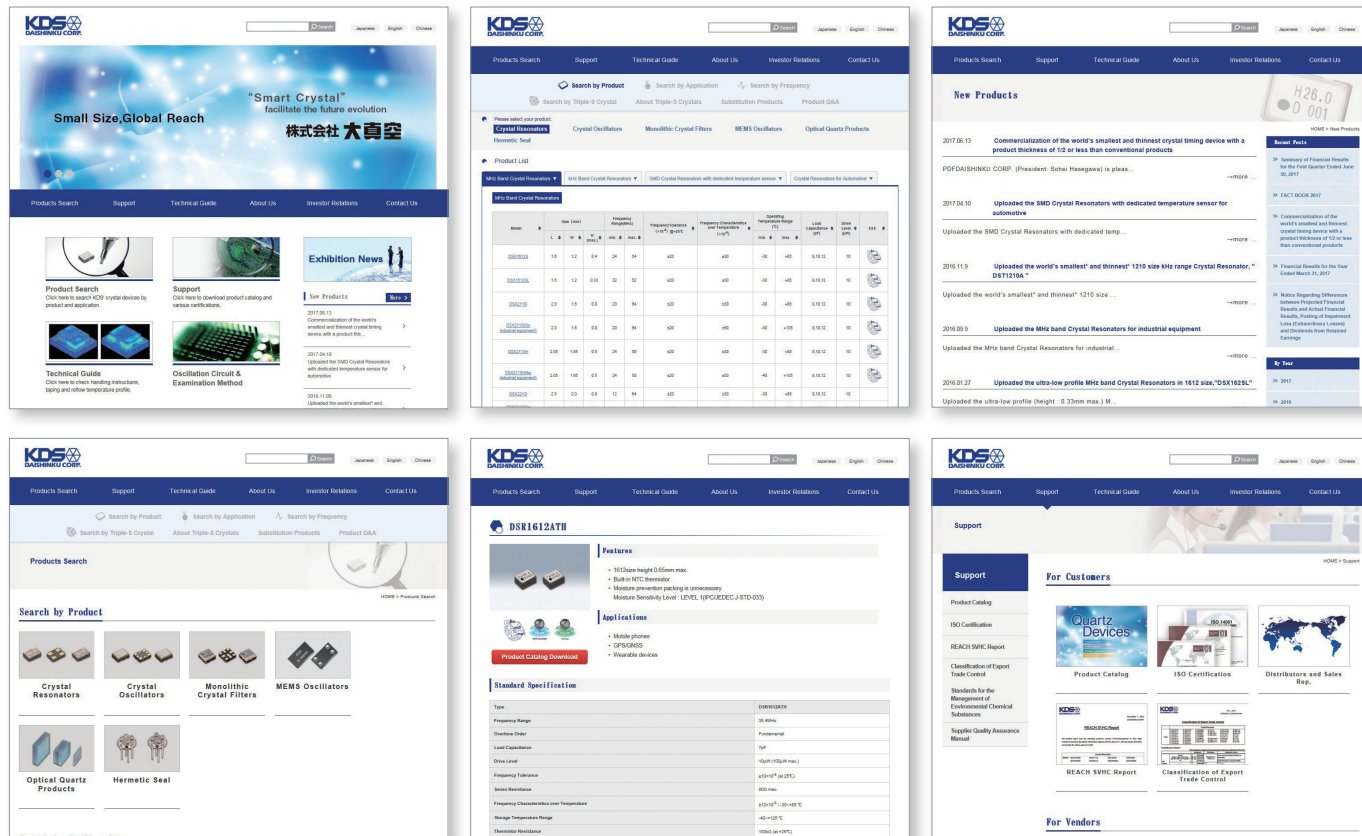

Contact us

The following link can be used to submit any inquires to us about KDS products including technical support or ordering products etc.

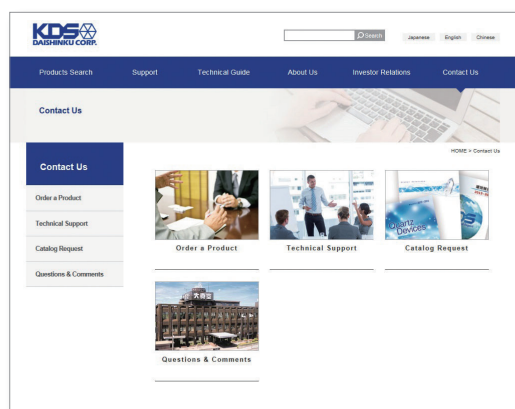

You may also contact us directory by e-mail.
e-mail address: kouhou602@kds.info

MEMO

A series of horizontal dashed lines for writing.

MEMO

A series of horizontal dashed lines for writing.

MEMO

A series of horizontal dashed lines for writing a memo.



KDS Global Network

Our global network accelerates our business.

All KDS business bases are connected through a global network via host computers. This network allows for online and real-time networking, thus maximizing time efficiency and ensures our promptness. This network maintains our quality standards through the control of production at our plants, product transport from/to the distribution center, and our sales information. In the best interest of our customers we continuously aim to deliver our quality services to the world market.

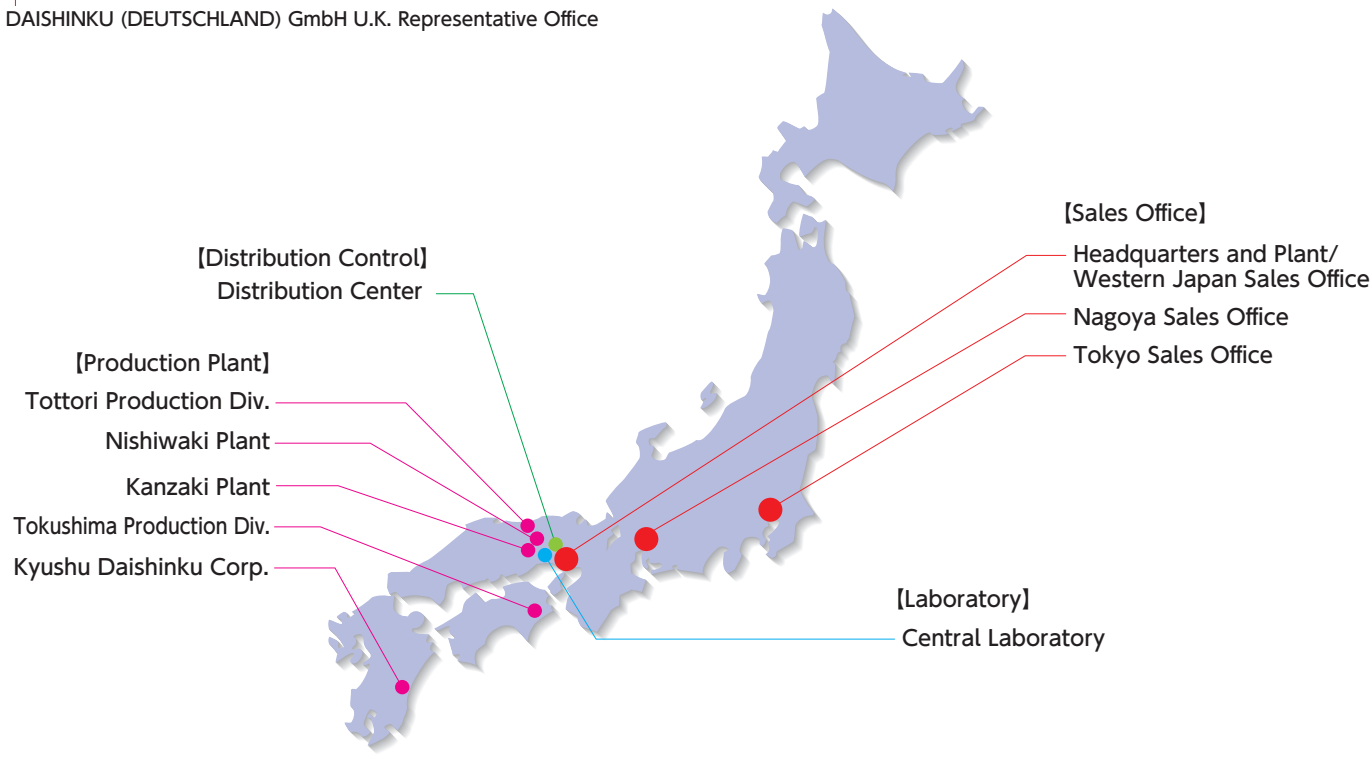
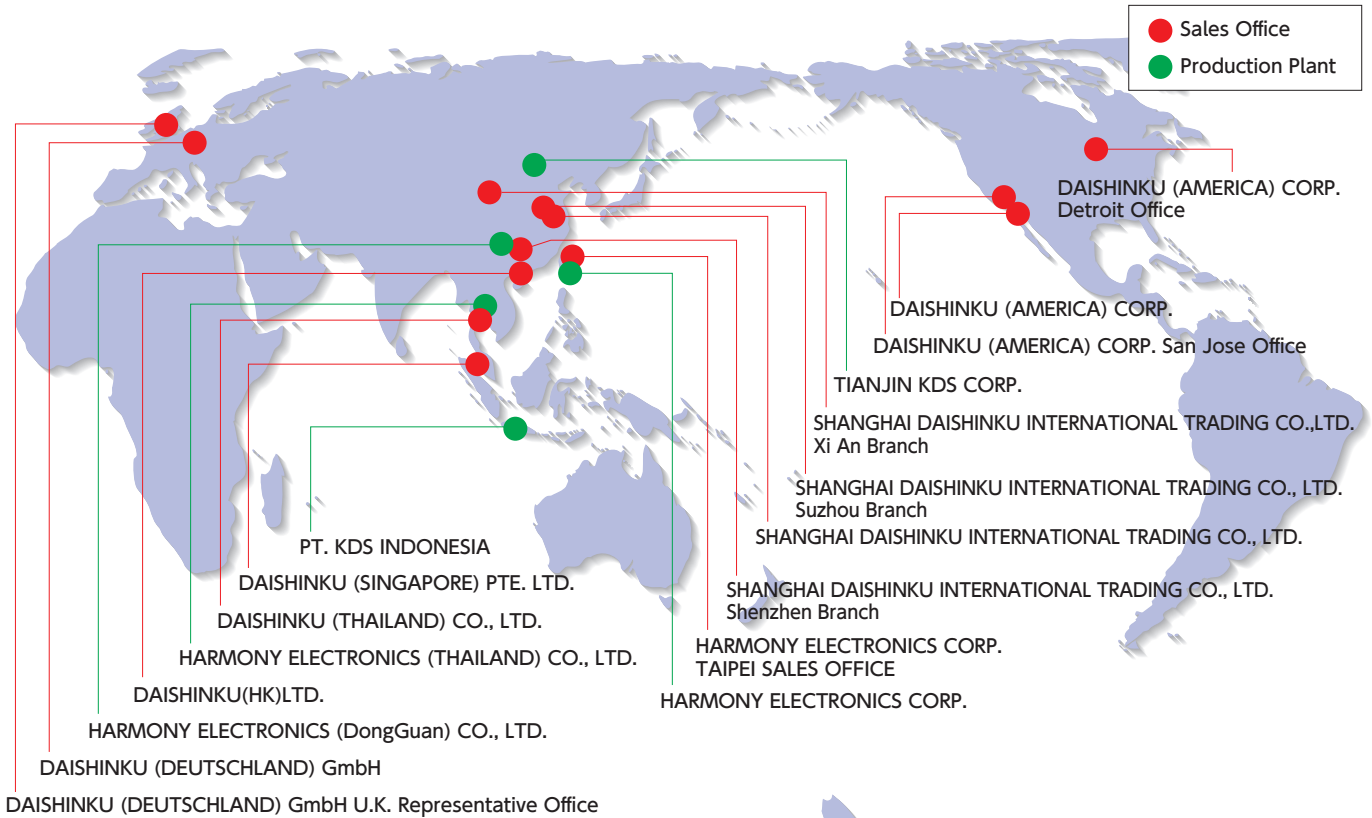



General Manufacturer of Quartz Devices

株式会社 大真空

DAISHINKU CORP.

<https://www.kds.info>

本 社 工 場 : 〒675-8565
兵庫県加古川市野口町水足179-6
TEL.(079)426-3211 / FAX.(079)426-8618
営業本部/西日本営業所 : TEL.(079)425-3161 / FAX.(079)425-1134
韓 国 営 業 : TEL.(079)425-3141 / FAX.(079)425-1134
東 京 営 業 所 : 〒140-0013
東京都品川区南大井3-28-3 大森プラザビル6F
TEL.(03)6404-3900 / FAX.(03)6404-3901
名 古 屋 営 業 所 : 〒460-0002
愛知県名古屋市中区丸の内3-20-17 KDX桜通ビル5階
TEL.(052)973-1661 / FAX.(052)973-1662

HEADQUARTERS AND PLANT

179-6 Mizuashi, Noguchi-cho, Kakogawa, Hyogo 675-8565, Japan
TEL:+81-79-426-3211 FAX:+81-79-426-8618

Marketing & Sales Div./Western Japan Sales Office

TEL:+81-79-425-3161 FAX:+81-79-425-1134

KOREA SALES SEC.

TEL:+81-79-425-3141 FAX:+81-79-425-1134

TOKYO SALES OFFICE

6F, 3-28-3 Minamioi, Shinagawa-ku, Tokyo 140-0013 Japan
TEL:+81-3-6404-3900 FAX:+81-3-6404-3901

NAGOYA SALES OFFICE

5F, 3-20-17 Marunouchi, Naka-ku, Nagoya, Aichi 460-0002, Japan
TEL:+81-52-973-1661 FAX:+81-52-973-1662

DAISHINKU (AMERICA) CORP.

17800 Newhope Street Suite F, Fountain Valley, CA 92708 U.S.A.
TEL:+1-714-641-2600 FAX:+1-714-641-2606

DAISHINKU (AMERICA) CORP. San Jose Office

2033 Gateway Place, Suite 500 San Jose, CA 95110 U.S.A.
TEL:+1-678-575-8795

DAISHINKU (AMERICA) CORP. Detroit Office

42705 Grand River Ave., Suite 201, Novi, MI 48375 U.S.A.
TEL:+1-714-600-0034

DAISHINKU (DEUTSCHLAND) GmbH

Wiesenstrasse 70A2 40549 Düsseldorf, F.R. Germany
TEL:+49-211-506530-0 FAX:+49-211-596054

DAISHINKU (DEUTSCHLAND) GmbH U.K. Representative Office

Brook House, 54a Cowley Mill Road, Uxbridge, Middlesex, UB8 2QE, U.K.
TEL:+44-20-3405-4913

DAISHINKU (SINGAPORE) PTE. LTD.

1 Kaki Bukit View, #04-08, Techview, Singapore 415941
TEL:+65-6286-7646

DAISHINKU (THAILAND) CO., LTD.

2098 M Tower, 2nd Floor, Room 204-205, Sukhumvit Road, Phra Khanong Tai
Sub-district, Phra Khanong District, Bangkok 10260 Thailand
TEL:+66-2-391-3291 FAX:+66-2-391-3292

DAISHINKU (HK) LTD.

Units 1-2, 22/F., Futura Plaza, 111-113 How Ming Street, Kwun Tong, Kowloon, Hong Kong
TEL:+852-2330-2541 FAX:+852-2765-6673

SHANGHAI DAISHINKU INTERNATIONAL TRADING CO., LTD.

906, 1#, No.641, Tianshan Road, Shanghai 200336 China
TEL:+86-21-6236-8701 FAX:+86-21-6236-8707

SHANGHAI DAISHINKU INTERNATIONAL TRADING CO., LTD.

Suzhou Branch

Room 1216, Gold River International Center, 88 Shishan Road, high-tech zone, Suzhou,
China

TEL:+86-512-6827-0470 FAX:+86-512-6827-0455

SHANGHAI DAISHINKU INTERNATIONAL TRADING CO., LTD.

Shenzhen Branch

Room 2404, Building 1, Shenzhen Huarong Building, Mintian Road, Futian District,
Shenzhen, China

TEL:+86-755-8831-6813 FAX:+86-755-8831-6812

SHANGHAI DAISHINKU INTERNATIONAL TRADING CO., LTD.

Xi An Branch

Room1112, Kaixin International Plaza, NO.130, Weiyang Road, Weiyang District, Xi'an
710016 China

TEL:+86-29-8154-1730 FAX:+86-29-8154-1731

HARMONY ELECTRONICS CORP. TAIPEI SALES OFFICE

5F NO.80, Zhouzi Street, Neihu District, Taipei City, Taiwan 114064
TEL:+886-2-2658-8883 FAX:+886-2-2658-8683

