

# 压纹载带包装(MEMS振荡器)

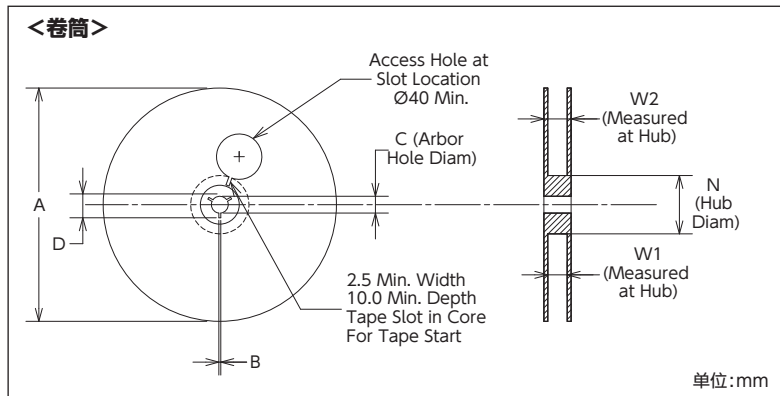
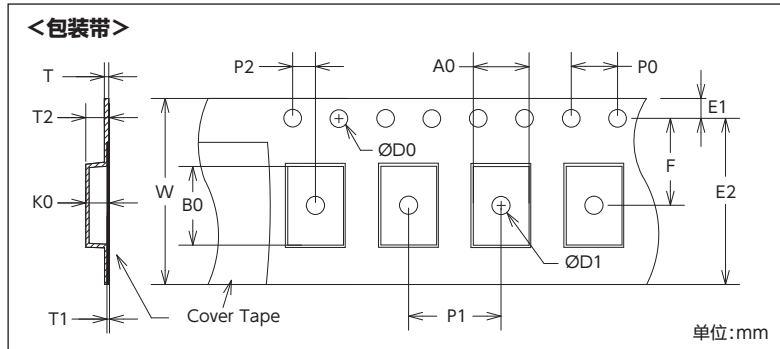
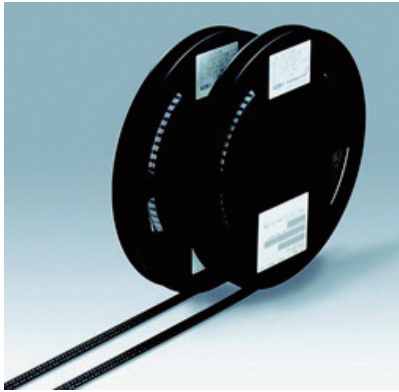

## 卷筒标准规格

Tape Size	A Max.	B Min.	C	D Min.	N	W1	W2 Max.
8	180	1.5	13.0 +0.6/-0.2	20.2	60 +0.5/-0.5	8.4 +1.5/-0	14.4
8	330	1.5	13.0 +0.2/-0.2	20.2	100 +0.5/-0.5	8.4 +1.5/-0	14.4
12	330	1.5	13.0 +0.2/-0.2	20.2	100 +0.5/-0.5	12.4 +2.0/-0	18.4
12	180	1.5	13.0 +0.2/-0.2	20.2	60 +0.5/-0.5	12.4 +2.0/-0	18.4
16	330	1.5	13.0 +0.2/-0.2	20.2	100 +0.5/-0.5	16.4 +2.0/-0	22.4
16	180	1.5	13.0 +0.2/-0.2	20.2	60 +0.5/-0.5	16.4 +2.0/-0	22.4

## 载带标准规格

Package Outline Drawing	Package Size	Tape Size	D0	D1 Min.	E1	E2 Min.	F	P0	P1	P2	T	T1 Max.	T2 Max.	W Max.	A0	B0	K0
POD-1	2.5×2.0×0.75	12	1.5 +0.1/-0.0	1.5	1.75 ±0.1	10.25	5.5 ±0.05	4.0 ±0.1	4.0 ±0.1	2.0 ±0.05	0.6	0.1	1.65	12.3	2.3 ±0.10	2.8 ±0.10	1.10 ±0.10
POD-1	2.5×2.0×0.75	8	1.55 ±0.05	1.0	1.75 ±0.1	5.85	3.5 ±0.05	4.0 ±0.1	4.0 ±0.1	2.0 ±0.05	0.3 ±0.05	0.1	1.65	8.3	2.25 ±0.05	2.8 ±0.05	1.10 ±0.10
POD-23	2.7×2.4×0.75	12	1.55 ±0.05	1.0	1.75 ±0.1	9.85	5.5 ±0.05	4.0 ±0.1	4.0 ±0.1	2.0 ±0.05	0.3 ±0.05	0.1	1.55	12.3	2.65 ±0.10	2.95 ±0.10	1.00 ±0.10
POD-23	2.7×2.4×0.75	8	1.55 ±0.05	1.0	1.75 ±0.1	5.85	3.5 ±0.05	4.0 ±0.1	4.0 ±0.1	2.0 ±0.05	0.3 ±0.05	0.1	1.55	8.3	2.65 ±0.10	2.95 ±0.10	1.00 ±0.10
POD-2	3.2×2.5×0.75	12	1.5 +0.1/-0.0	1.5	1.75 ±0.1	10.25	5.5 ±0.05	4.0 ±0.1	4.0 ±0.1	2.0 ±0.05	0.6	0.1	1.65	12.3	2.8 ±0.10	3.5 ±0.10	1.10 ±0.10
POD-2	3.2×2.5×0.75	8	1.5 +0.1/-0.0	1.0	1.75 ±0.1	5.95	3.5 ±0.05	4.0 ±0.1	4.0 ±0.1	2.0 ±0.05	0.2 ±0.05	0.1	1.65	8.2	2.7 ±0.10	3.4 ±0.10	1.15 ±0.10
POD-3	5.0×3.2×0.75	12	1.5 +0.1/-0.0	1.5	1.75 ±0.1	10.25	5.5 ±0.05	4.0 ±0.1	8.0 ±0.1	2.0 ±0.05	0.6	0.1	1.65	12.3	3.5 ±0.10	5.3 ±0.10	1.10 ±0.10
POD-4	7.0×5.0×0.90	16	1.5 +0.1/-0.0	1.5	1.75 ±0.1	14.25	7.5 ±0.10	4.0 ±0.1	8.0 ±0.1	2.0 ±0.10	0.6	0.1	1.80	16.3	5.4 ±0.10	7.4 ±0.10	1.3 ±0.10
POD-9	3.5×3.0×0.30	12	1.5 +0.1/-0.0	1.5	1.75 ±0.1	10.25	5.5 ±0.05	4.0 ±0.1	8.0 ±0.1	2.0 ±0.05	0.6	0.1	1.65	12.3	3.3 ±0.10	3.8 ±0.10	0.65 ±0.10
POD-26	2.0×1.6×0.75	8	1.55 ±0.05	0.9	1.75 ±0.1	6.05	3.5 ±0.05	4.0 ±0.1	4.0 ±0.1	2.0 ±0.05	0.3 ±0.05	0.1	1.55	8.3	1.9 ±0.05	2.3 ±0.05	1.00 ±0.10
POD-29	2.0×1.2×0.60	8	1.55 ±0.05	1.0	1.75 ±0.1	6.05	3.5 ±0.05	4.0 ±0.1	4.0 ±0.1	2.0 ±0.05	0.25 ±0.05	0.1	1.55	8.3	1.9 ±0.05	2.3 ±0.05	1.00 ±0.10
POD-32	1.5×0.8×0.60	8	1.55 ±0.05	0.18	1.75 ±0.1	6.05	3.5 ±0.05	4.0 ±0.1	4.0 ±0.1	2.0 ±0.05	0.2 ±0.02	0.1	1.55	8.3	0.96 ±0.03	1.66 ±0.03	0.63 ±0.03
SOT-23	2.8×1.6×1.45	8	1.55 ±0.05	1.0	1.75 ±0.1	6.05	3.5 ±0.05	4.0 ±0.1	4.0 ±0.1	2.0 ±0.05	0.25 ±0.02	0.1	1.62	8.3	3.23 ±0.10	3.17 ±0.10	1.37 ±0.10

关于压纹载带包装规格的详细信息请确认数据表。